

600KVA **MODULAR UPS**

PS-PMU600K50#46BC0K

USER MANUAL



Foreword

Summaries

Thank you for choosing the modular PS series modular UPS!

This document gives a description of the PS series modular UPS, including the features, performance, appearance, structure, working principles, installation, operation and maintenance.etc.



Please save the manual after reading, in order to consult in the future.





Suitable Model

- PS75KVA
- PS125KVA
- PS200KVA
- PS300KVA
- PS400KVA
- PS500KVA
- PS600KVA

Symbol Conventions

The manual quotes the safety symbols, these symbols used to prompt users to comply with safety matters during installation, operation and maintenance. Safety symbol meaning as follows.

Symbol	Description
 DANGER	Alerts you to a high risk hazard that could, if not avoided, result in serious injury or death.
 WARNING	Alerts you to a medium or low risk hazard that could, if not avoided, result in moderate or minor injury.

Symbol	Description
 CAUTION	Alerts you to a potentially hazardous situation that could, if not avoided, result in equipment damage, data loss, performance deterioration, or unanticipated results.
	Anti-static prompting.
	Be care electric shock prompting.
 TIP	Provides a tip that may help you solve a problem or save time.
 NOTE	Provides additional information to emphasize or supplement important points in the main text.

Product standard: Q/ZZKJ 007

Change History

Changes between document issues are cumulative. The latest document issue contains all the changes made in earlier issues.

Issue 003 (2019-10-30)

Change the structure layout.

Issue 002 (2019-10-18)

Change the structure of PS400KVA, PS500KVA, PS600KVA.

Issue 001 (2019-09-30)

First issue.

Contents

1 Safety Description.....	1
1.1 Safety Announcements.....	1
1.1.1 Safety Instructions	1
1.1.2 Use Announcements for Battery	4
1.1.3 Anti-Static Protection.....	5
1.1.4 Grounding Requirements	5
1.1.5 Safety Warning Label Setting	5
1.2 Operation and Maintenance Requirements	5
1.3 Environment Requirements.....	7
2 Overview.....	8
2.1 Product Intro.....	8
2.2 Features	8
2.3 Work Principle.....	10
2.3.1 Work Principle Diagram	10
2.3.2 Work Mode	10
2.4 Structure	12
2.4.1 Operation Panel.....	13
2.5 Sturcture Layout.....	14
2.5.1 PS75KVA, PS125KVA, PS200KVA, PS300KVA (Bottom wiring).....	14
2.5.2 PS200KVA, PS300KVA (Top wiring).....	15
2.5.3 PS400KVA, PS500KVA, PS600KVA	16
2.5.4 Power Module.....	16
2.5.5 Bypass Module.....	18
2.5.6 System Control Box.....	19

2.6 Alarm Function.....	24
3 Installation.....	27
3.1 Installation Procedure.....	27
3.2 Installation Preparation	28
3.2.1 Installation Tools.....	28
3.2.2 Installation Environment.....	29
3.2.3 Installation Space	30
3.2.4 Input and Output Wire Selection.....	30
3.2.5 Surge Protection Device.....	33
3.2.6 Reverse Feedback Protection (Optional).....	33
3.3 Transportation and Unpacking	33
3.3.1 Transportation	33
3.3.2 Unpacking	35
3.4 Mechanical Installation	36
3.5 System Wiring.....	40
3.5.1 PS75KVA, PS125KVA(Compatible with top and bottom incoming wires) & PS200KVA, PS300KVA (Bottom wiring)	40
3.5.2 PS200KVA, PS300KVA (Top wiring)	43
3.5.3 PS400KVA, PS500KVA, PS600KVA	46
3.6 Parallel System Connection	50
3.7 System Check and Test.....	53
3.7.1 Check Electrical Connection.....	53
3.7.2 UPS Test.....	53
3.7.3 Connect Load.....	54
4 Touch Screen Operation and Setting	55
4.1 Menu Structure.....	55
4.2 Main Page	56
4.3 System Work Status Display	57
4.4 Buzzer Control Function	63
4.5 Monitor Function	64

4.5.1 Bypass Information	64
4.5.2 Mains Information	64
4.5.3 Battery Information.....	65
4.5.4 Power Module Information.....	66
4.5.5 Inverter Information.....	67
4.5.6 Output Information	67
4.6 Setting Management.....	68
4.6.1 System Manage.....	69
4.6.2 Battery Manage.....	71
4.6.3 Mode Configuration.....	73
4.6.4 Function Configuration.....	75
4.6.5 Communication Setting.....	78
4.6.6 Debug Set.....	79
4.6.7 Record Manage	80
4.6.8 HMI Set.....	80
4.6.9 Password Set	81
4.7 Information Query.....	82
4.7.1 Event log	83
4.7.2 User Log	83
4.7.3 Device Information	84
4.8 ON/OFF	86
5 Use and Operation	88
5.1 Use Announcements	88
5.2 Operation Procedure.....	88
5.3 UPS Start and Shutdown	89
5.3.1 Check before Startup.....	89
5.3.2 Startup.....	89
5.3.3 UPS Shutdown.....	91
5.3.4 Switch to Bypass Mode Manually	92
5.3.5 Switch to Maintenance Bypass Mode From Normal Output	92

5.3.6 Switch to Inverter Power Supply from Maintenance Bypass.....	93
5.3.7 Emergency Power Off (EPO).....	94
5.3.8 Emergency Power Off Recovery.....	94
5.4 Parallel System Startup and Shutdown.....	94
5.4.1 Start Parallel System	94
5.4.2 Shutdown Parallel System	97
5.4.3 Emergency Power Off (EPO).....	98
6 Maintenance and Troubleshooting	99
6.1 Maintenance Guide	99
6.1.1 Safety Precautions.....	99
6.1.2 Preventive Maintenance.....	99
6.2 Battery Maintenance	100
6.3 Announcements for Battery Replacement	100
6.4 Troubleshooting.....	101
6.4.1 Common Abnormal Phenomena Diagnosis	101
6.4.2 Emergency Dispose for System Fault	103
7 Package, Transportation and Storage.....	104
7.1 Package	104
7.2 Transportation	104
7.3 Storage	104
A Technical Specifications	105
B Physics Characters.....	108
C Acronyms and Abbreviations	110

1 Safety Description

This chapter introduces the safety announcements. Prior to performing any work on the UPS, please read the user manual carefully to avoid human injury and device damage by irregular operations.

1.1 Safety Announcements

This section introduces the safety announcements that must be complied with and pay special attention while installing, using, maintenance and other relative operations.



CAUTION

Before operating, please read the announcements and operation instructions in this section carefully, which is to avoid accident.

The DANGER, WARNING, CAUTION in the manual are not all the safety announcements that you must abide by, they are just the supplements for the safety announcements during operating.



NOTE

Our Company does not undertake the responsibility caused by violating common safety operation requirements or the safety standard of design, manufacture and use.

1.1.1 Safety Instructions



CAUTION

The input and output of the UPS is dangerous high voltage, once operate improperly, it may endanger human safety. Please read this manual carefully before installing or operating, and pay attention to the warning labels. Do not dismantle the case of the UPS unless authorized person.

**DANGER**

It is prohibited to touching any terminal or conductor that connected with grid circuit, or, it may cause deadly danger.

**DANGER**

The damaged device or device fault may cause electric shock or firing!

- Before operating, please inspect the device and see if there is any damage or exist other danger.
 - Check if the external devices or circuit connection is safe.
-

**WARNING**

Touching high voltage directly or through damp objects will lead to lethal risk.

**DANGER**

During a lightning storm, it is strictly prohibited to perform high voltage and AC operation, as well as in the tower or the mast. The atmosphere will generate a strong electromagnetic field in a lightning storm. Therefore, in order to avoid equipment struck by lightning, lightning protection and grounding system should be prepared in time.

**WARNING**

Do not reversely connect the grounding wire and neutral wire, live wire and neutral wire, which will cause short circuit.

It should be well grounded and the voltage between ground wire and neutral wire should be less than 5V.

**WARNING**

If the output of the UPS cannot be half-wave rectification load or inductive load, such as air-condition, hair drier, starter, electric drill, motor, daylight lamp, etc.

**WARNING**

Please do not put finger or tool into rotating fans to avoid endanger the human safety or damage the device.

**WARNING**

In case of fire, please use dry power fire extinguisher. If using liquid fire extinguisher, it may cause electric shock.

**CAUTION**

No liquid or other objects are allowed to enter the cabinet.

**CAUTION**

Keep good ventilation! Ensure that the air inlet and outlet and fan unblocked.

**CAUTION**

The product is class C3 device. If it is used in the environment that includes all commercial, light industry and industrial establishments other than those directly connected to a low-voltage mains that supplies building used for residential purpose, it may cause wireless interference. User should take actions to avoid the interference.

**CAUTION**

Warning label should be affixed away from UPS location!

When UPS is power off, there still exists dangerous voltage. It should affix warning labels away from UPS location and the warning labels should include: 1. It supplies power for UPS. 2. Please disconnect UPS before wiring.

1.1.2 Use Announcements for Battery

**CAUTION**

Please use specified battery. Non-specified battery will damage the UPS.

The charging voltage of different brand and different model battery is different. Before using, ensure that the charging voltage of the UPS matches that of battery. If doubted, please consult the manufacturer for support.

**WARNING**

Battery operation must be done according to instructions!

Battery operation must be done according to instructions, especially battery wiring. Irregular operation will cause battery damage, even human injury.

- It is prohibited to short circuit the anode and cathode of the battery. The battery wiring must be tightened. It is strictly prohibited to touch any two wiring terminals of battery or the bare terminals of wires simultaneously, or it may cause battery damage or human injury.
- Prevent electrolyte leaking from batteries. The metal objects and circuit board will be corroded by the overflowing electrolyte and it will result in equipment damage and circuit board short circuit.
- Keep the battery away from fire source and all device that easy cause spark to avoid danger or unnecessary lose.

1.1.3 Anti-Static Protection



CAUTION

The static generated by human bodies may damage the electrostatic-sensitive components on PCB. Before touching the sensitive component, please wear anti-static rings and well connect the other end of the anti-static rings to ground.

1.1.4 Grounding Requirements



WARNING

High leakage risk! The device must be grounded before electrical connection. The grounding terminal must be connected to earth.

- When installing, connect the grounding wire first; when dismantling, the grounding wire must be removed at last.
- It is prohibited to damage the grounding conductor.
- The device must be connected with protection earthing permanently. Before operating, please check the electric connection and ensure the device has been connected to earth reliably.

1.1.5 Safety Warning Label Setting

To avoid irrelevant person close to or misoperate the UPS, during installation or daily maintenance, please comply with the related standards.

- Set warning labels at the switches of input end and output end to avoid wrongly close and even cause accident.
- Set warning label or safety warning area to avoid irrelevant person entering and cause human injury or device damage.
- After maintenance, ensure that pull out the key of the UPS and save it properly.

1.2 Operation and Maintenance Requirements

There exists high temperature and high voltage inside the UPS. Please comply with the relevant safety regulations and operation procedures during installation, operation and maintenance to avoid human injury or device damage. The safety precautions mentioned in the user manual is just as a

supplement to the local safety regulations. Our company does not undertake the responsibility caused by violating the common safety operation requirements or safety standards for design, manufacture and use the device.



CAUTION

The related operation and wiring for the UPS should be performed by qualified professionals, and ensure the electric installation accord with the electricity installation standards.

The installation and maintenance man should be trained and know each safety announcements and get the right operation method, and then, the installation, operation and maintenance can be done.



DANGER

Mounting and dismantling power cables is prohibited when power on. Please switch off the power switches before mounting or dismantling power cables. Before connecting, make sure the cable connection, cable labels are in accordance with the actual installation.

- Only authorized professionals are allowed to open the UPS chassis! The input and output of UPS are dangerous high voltage. Touching high voltage will lead to lethal risk.
- Before maintenance, please disconnect the AC power and battery to isolate the power input. It is better to measure the input, output and battery terminal bars by a voltmeter to ensure the input power is disconnected and in a safe condition.
- Even if all external power is disconnected, there still exists residual electric charge on the capacitance inside the UPS, and the output terminal bars may exists high voltage which endangers human life. It is necessary to set the UPS aside for enough time (≥ 10 min) to release all charge before opening the UPS chassis.
- The battery cables are not isolated with AC input. There may exist dangerous voltage between battery terminal and grounding terminal. Pay attention to the insulation when installing and using the battery.
- Do not wear conductive objects, such as watches, bracelets and rings during operating.

**WARNING**

Drilling holes on the cabinet is prohibited! Inappropriate drilling will damage the components inside the UPS. Metal debris generated by drilling will lead to circuit board short circuit.

**NOTE**

Changing the UPS configuration, structure or assembly will affect the performance of the UPS. If user needs to do like this, please consult the manufacturer in advance.

1.3 Environment Requirements

**DANGER**

Do not put the UPS in the environment where has inflammable, explosive gas or smog, do not do any operation in this environment.

The operation about any electronics device in explosive environment is exceeding danger, while using or storing the UPS, please strictly according to the environment mentioned in the manual.

The operation environment of UPS should meet the following requirements.

- Please meet the technical specification for equipment operation (temperature: 0°C-40°C, relative humidity: 0%-95%).
- Please keep it well ventilated and far away from water sources, heat sources and inflammable and explosive goods.
- The altitude shall not exceed 1000m. If the altitude exceeds 1000m, it shall be reduced according to GB/T3859.2.
- Please avoid using the device in the following environment for long time.
 - The place where has direct sunshine or near a heat source.
 - The place where has metallic conductive dust.
 - The place where has dust, corrosive material, high salty or volatile gas.

2 Overview

This chapter mainly introduces the product features, work principle, structure of the UPS, including panel indicator meaning and signal port illustration.

2.1 Product Intro

PS series UPS is modular online double-conversion UPS. They are made up of cabinet, power module, bypass module, system control box and distribution unit. The system is designed in module and user can online add /decrease or replace the power module conveniently and do not worry about the normal operation of system. The system is high performance sine-wave UPS that special designed for the network computer room and precision instrument of financial, communication, insurance, transportation, tax, army, security, energy source, education, government, enterprise, etc.

2.2 Features

Hot swappable

The power module adopts none-principle-subordinate parallel control technique, each power module is independent and do not need to match each other strictly. They can be put into use or exit online at will, which achieves the online hot maintenance. The system has high adaptability, availability, expandability and low cost.

Three-level inversion technology

Adopts three-level inversion technology, which makes the quality of output voltage wave better and the efficiency of whole UPS higher.

Completely digitalized DSP control

Adopts digitalized DSP to control the inverting, phase synchronization, output current-sharing, logic of the power unit, which is with high precision, high speed and perfect whole system performance.

Energy conservation and high efficiency

Adopts advanced PFC control technology, the input power factor is greater than 0.99, which greatly improves the use ratio of electric energy and reduces the load of power grid, and save the cost of power distribution. The size of whole UPS is small, and the weight is light, calorific value is small, which enhances the use ratio of environment and decrease the investment cost.

Smart fan speed control

The fan speed is adjusted automatically in accordance with the load status, which prolong fan life and reduce noise.

ECO energy conservation mode design

The UPS is designed with ECO energy conservation mode. When the user power grid is good, if the UPS operating in this mode, the bypass prior to output, and the efficiency can be 99%.When the bypass voltage or frequency out of normal range and cannot satisfy the user's power supply requirement, it will switch to inverter output, and this guarantee the reliability of power supply and also, save energy.

Manual maintenance bypass design

It designs manual maintenance bypass channel to ensure the UPS supply power for load while maintenance, which greatly improve the system operation reliability and maintainability.

Reliable EMC performance

Pass the authority institution and professional test on EMC, including conducting disturbance, radioactive disturbance, conducting anti-disturbance, radioactive anti-disturbance, power falling, mass impulse, static discharging, surge, etc. The excellent EMC characteristics can completely filter each power grid interference, and also, decrease and eliminate the interference of UPS itself effectively.

7 inch touch screen display

With 7 inch touch screen display, the operation is simple and convenient, which is convenient to daily manage and maintain the UPS. It can display the running parameters and running status of UPS and each power unit, and record the history event and alarm information. It can store 10000 pieces of information at most.

2.3 Work Principle

2.3.1 Work Principle Diagram

Work principle diagram of the UPS is as shown in Figure2-1.

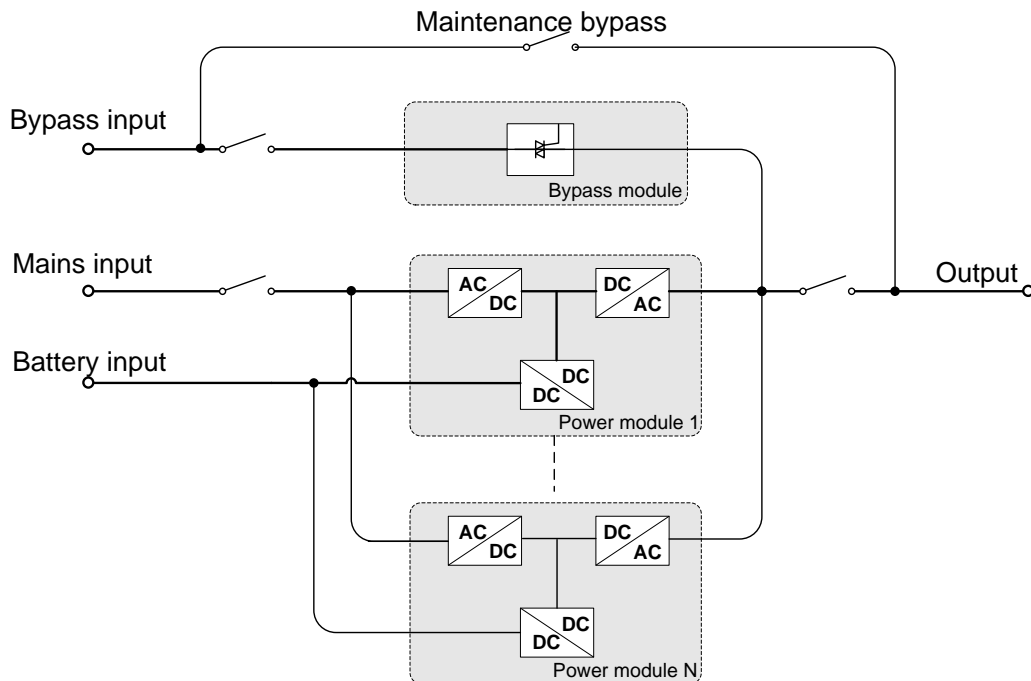

Figure2-1 Work principle diagram

2.3.2 Work Mode

There are 4 work modes of the PS series modular UPS: normal mains power supply mode, battery power supply mode, bypass power supply mode and maintenance bypass power supply mode.

Normal mains power supply mode

When the mains normal, AC power is transformed to DC power by PFC, and supply power for inverter. While rectifying the AC power into DC power, the rectifier eliminates the abnormal noise wave, noise and unstable frequency, and make the inverter provide stable and clean power for load. The specific work process is as follows.

When mains normal, the rectifier, inside the power unit, rectify the mains into anode and cathode DC voltage, and store energy in DC electrolysis for inverter to use. The inverter absorbs energy from DC electrolysis and inverts to output stable 220Vac voltage. When the system detects the inverter normal, it will supply the inverting voltage to load.

Battery power supply mode

When mains abnormal, system will switch to battery input, the Boost circuit promotes the battery voltage to a certain value and then supply the DC power to the inverter, that makes the AC output without interruption phenomenon and then protect the load. The specific work process is as follows.

When mains abnormal at any time, the rectifier will switch to battery input immediately to maintain the voltage of DC electrolysis, which guarantee the inverter without power down. Before battery discharge completely, if mains recovers, the rectifier will switch to mains input and charge battery at the same time. During the switch between grid power supply and battery power supply, the inverter output cannot power down.

In battery power supply mode, if mains does not recover normal all the time, and the battery energy is running out, the UPS will send sound & light alarm, and stop working at the max. discharge point, and long beeps to alarm. At that time, the load will power down.

Bypass power supply mode

When system abnormal (such as over-temperature, short-circuit, output voltage abnormal or overload) and exceed the bear range, the inverter will shut down to avoid damage automatically. If mains still normal at this time, it will turn to bypass to supply power for load. The specific work process is as follows.

If the inverter circuit fault or inverter overload and exceed the bear range, the UPS will turn to bypass to output. During bypass power supply, if fault or overload removed, the UPS will start inverter and begin to supply power for load. When the load is serious overload and exceeds the bypass bear range, the UPS will close the bypass output, and it will cause user load power down. When load fault or short circuit, the UPS will switch to bypass to supply power from inverter. If the short-circuit is serious, the UPS mains breaker and bypass breaker may trip out. After suffering the short-circuit fault, UPS will try to restart. If the short-circuit is removed, the UPS will switch to inverter; if the fault is not removed, the UPS will try to restart for 5 times. 5 times later, the UPS will turn to fault protection. At this time, it needs to power off or press the touch screen to shut down the UPS, and restart the UPS, and then, it will recover normal work.

Maintenance bypass power supply mode

When the UPS needs to be maintained and the power supply for load cannot be interrupted, user can shut down the inverter and make the UPS works in bypass status, then switch on the maintenance bypass breaker and switch off the mains pint breaker and bypass power supply breaker. During the

transforming of manual maintenance bypass, AC power is supplied for load by maintenance bypass breaker. At this time, the inner UPS has no electricity, maintainer can perform the maintenance safely.

2.4 Structure

PS series modular UPS is mainly made up of cabinet, operation panel, power module, bypass module, system control box, distribution plate, etc. The appearance of PS series modular UPS is as shown in Figure2-2, Figure2-3.

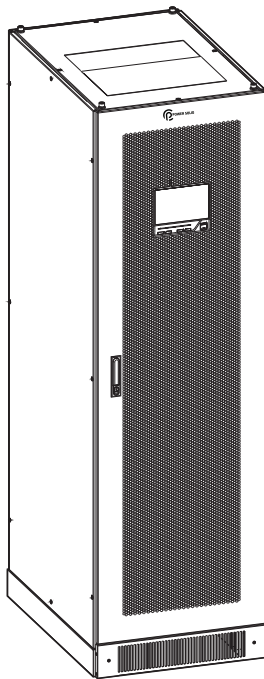

Figure2-2 Appearance of PS75KVA、 PS125KVA, PS200KVA, PS300KVA

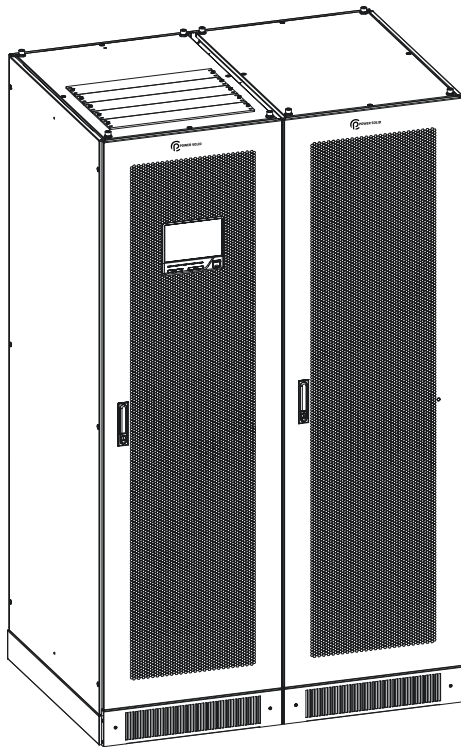

Figure2-3 Appearance of PS400KVA, PS500KVA, PS600KVA

2.4.1 Operation Panel

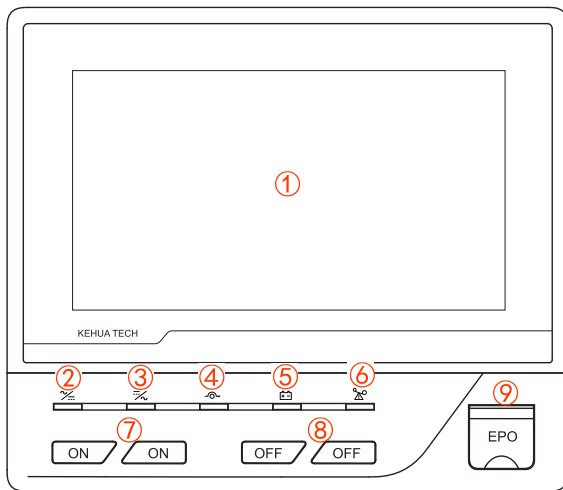

Figure2-4 Operation panel of PS series modular UPS

Table2-1 Illustration for the operation panel

NO.	Name	Illustration
①	Touch screen	Human-machine interactive interface

NO.	Name	Illustration
②	AC/DC indicator	On (green): the rectifier work normally. On (red): the rectifier work abnormally.
③	DC/AC indicator	On (green): the inverter work normally. On (red): the inverter work abnormally.
④	BYP. indicator	On (green): bypass output On (red): bypass abnormal
⑤	BATT. LOW indicator	On (green): battery low-voltage
⑥	OVERLOAD indicator	On (red): overload
⑦	ON combination button	Press the two buttons for 3s, the system will power on.
⑧	OFF combination button	Press the two buttons for 3s, the system will power off.
⑨	EPO emergency power off button	Press the button, the system will power outage immediately.

2.5 Sturcture Layout

NOTE

The system layout diagram takes the power module full allocation as an example, please refer to the real product.

2.5.1 PS75KVA, PS125KVA, PS200KVA, PS300KVA (Bottom wiring)

NOTE

PS75KVA, PS125KVA compatible with top and bottom incoming wiring mode.

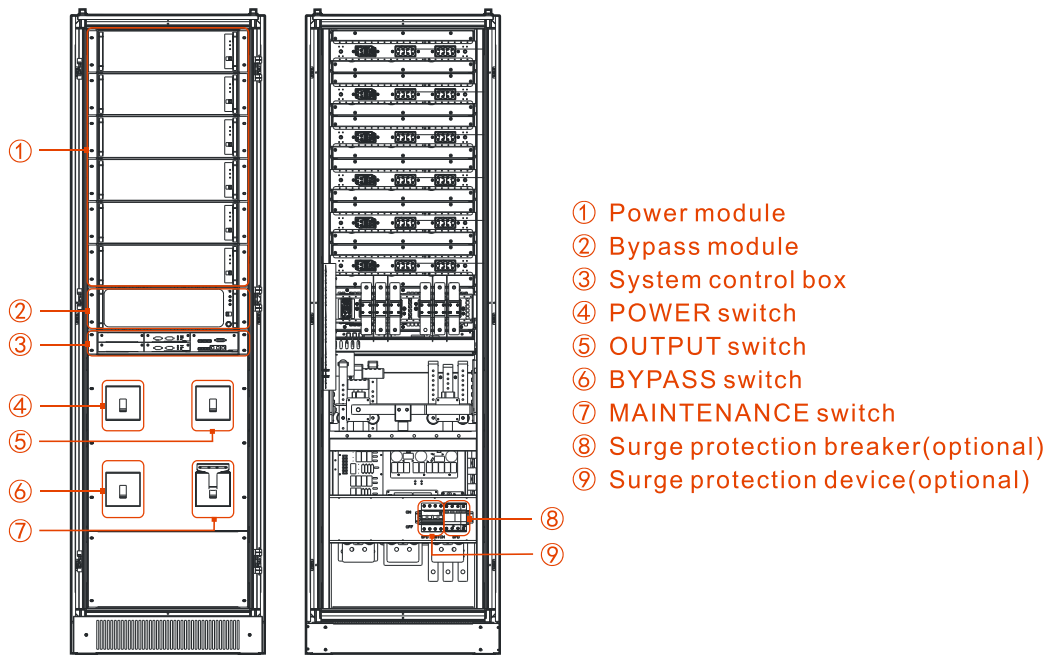

Figure2-5 System layout diagram of PS75KVA, PS125KVA, PS200KVA, PS300KVA (bottom wiring)

2.5.2 PS200KVA, PS300KVA (Top wiring)

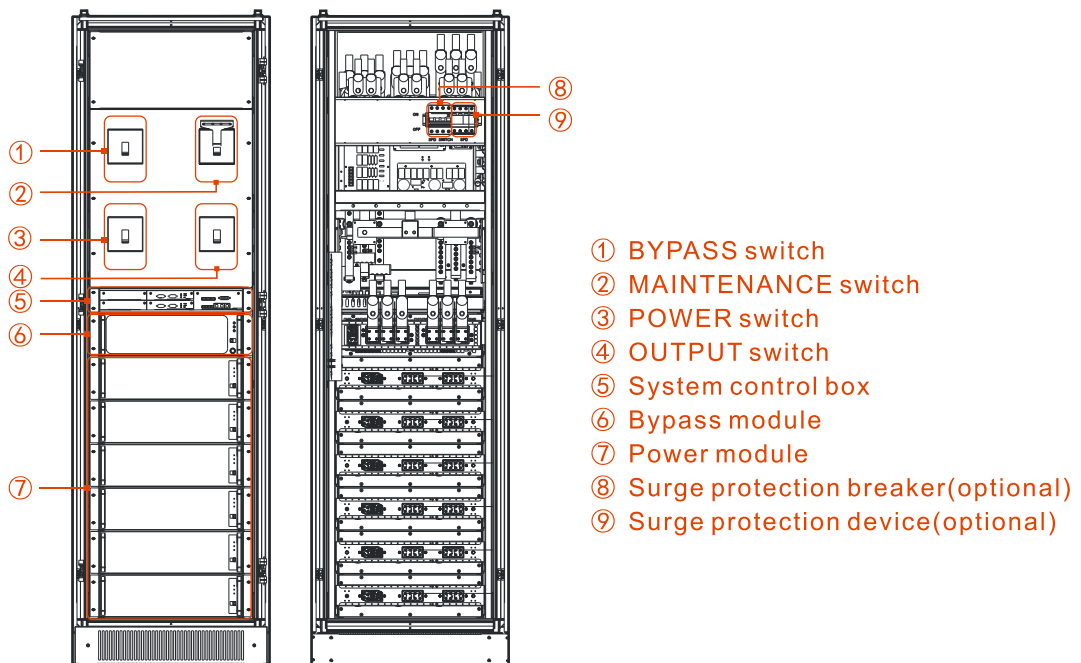

Figure2-6 System layout diagram of PS200KVA, PS300KVA (top wiring)

2.5.3 PS400KVA, PS500KVA, PS600KVA

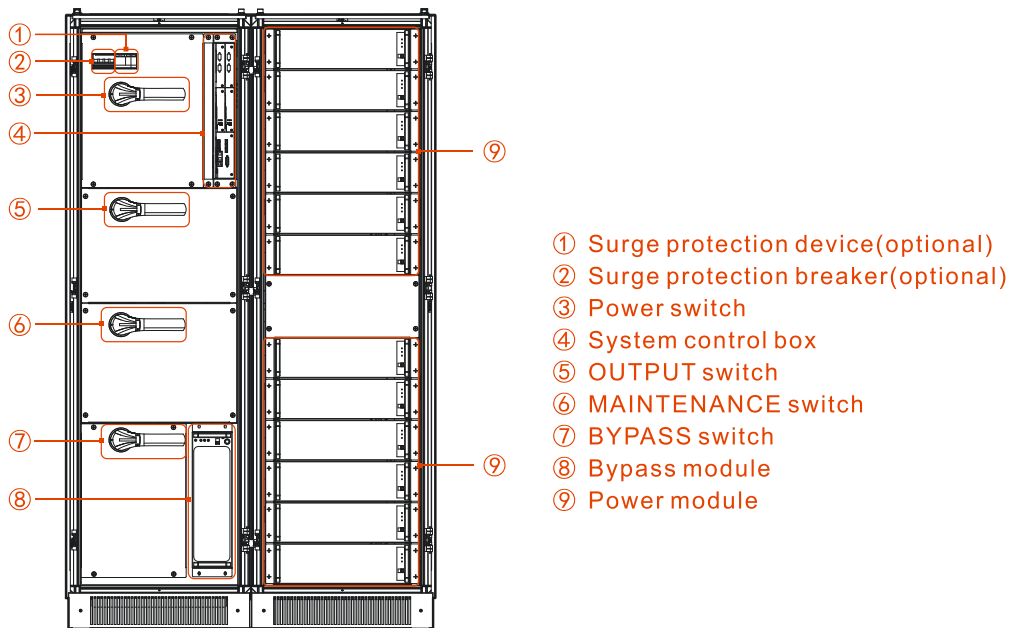

Figure2-7 System layout diagram of PS400KVA, PS500KVA, PS600KVA (open front door)

2.5.4 Power Module

Appearance

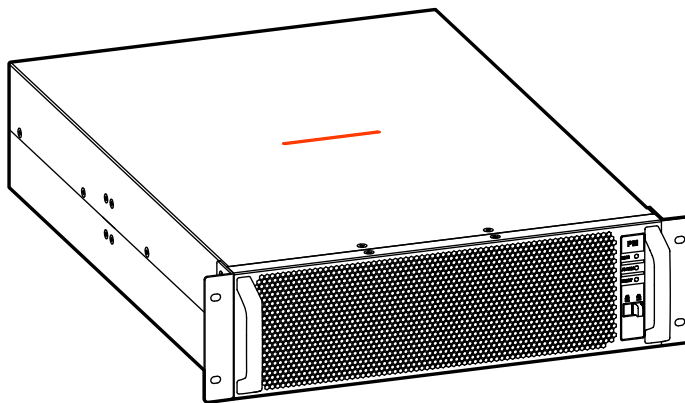

Figure2-8 Appearance of power module

Operation panel

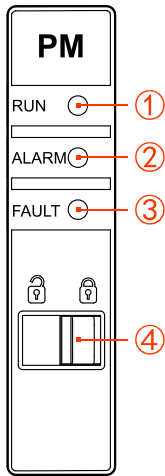

Figure2-9 Operation panel of power module

Table2-2 Illustration for the operation panel of power unit

NO.	Name	Illustration
①	RUN indicator (green)	On: power module stay in inverter status Flicker: power module stay in standby status.
②	ALARM indicator (yellow)	On: power module input voltage abnormal, fan abnormal, overload, etc.
③	FAULT indicator (red)	On: power module fault.
④	Ready switch	<ul style="list-style-type: none"> ● Place the ready switch to “unlock” status, the indication color is green, the power module is not locked with the cabinet, and at this time, the power unit can be dismantled. ● Place the ready switch to “lock” status, the indication color is red, the power module is locked with the cabinet, and at this time, the power unit cannot be dismantled.

2.5.5 Bypass Module

Appearance

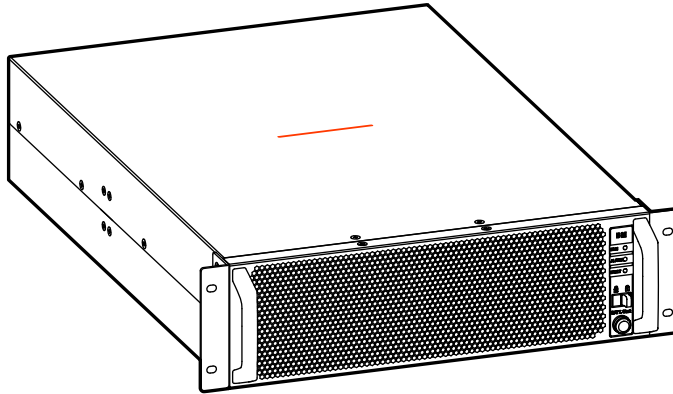

Figure2-10 Appearance of bypass module

Operation panel

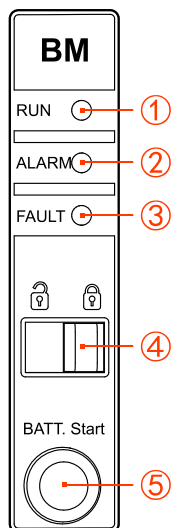

Figure2-11 Operation panel of bypass module

Table2-3 Illustration for the operation panel of bypass unit

NO.	Name	Illustration
①	RUN indicator (green)	On: bypass unit is running.
②	ALARM indicator (yellow)	On: bypass unit input voltage abnormal, fan abnormal, etc.
③	FAULT indicator (red)	On: bypass unit fault.

NO.	Name	Illustration
④	Ready switch	<ul style="list-style-type: none"> ● Place the ready switch to “unlock” status, the indication color is green, the bypass module is not locked with the cabinet, and at this time, the bypass module can be dismantled. ● Place the ready switch to “lock” status, the indication color is red, the bypass module is locked with the cabinet, and at this time, the bypass module cannot be dismantled.
⑤	Battery start button	At the status of no mains, bypass, press the button for 2s, the system will start from battery status.

2.5.6 System Control Box

The system control box unit is as shown inFigure2-12.

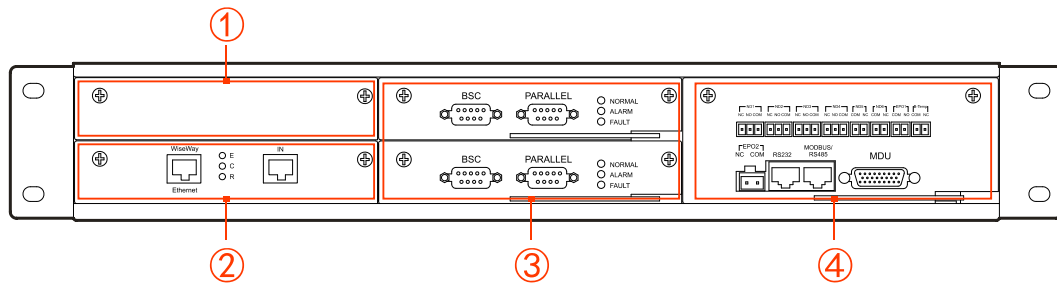

Figure2-12 System control box unit

Table2-4 Illustration for system control box unit

NO.	Name	Illustration
①	Reserved slot position of expansion card	Install corresponding function expansion card according to function requirements
②	SNMP card (optional)	It can realize the remote manage for the UPS. Detail operation and setting please see the user manual of network adapter.
③	System control card	Manage the module output, and control the system parallel operation and output double busbar synchronization. The lower is system card 1, The upper is system card 2.
④	System monitor card	Includes communication port, output dry contact and input dry contact.

SNMP card (optional)

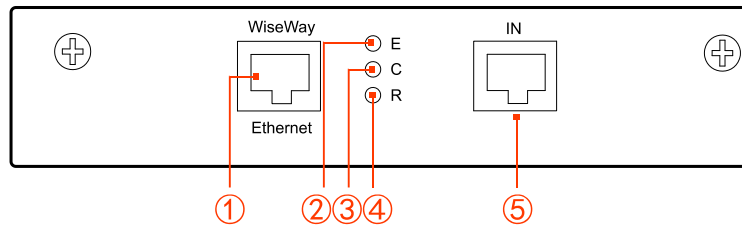

Figure2-13 SNMP card

Table2-5 Illustration for SNMP card

NO.	Name	Illustration
①	Ethernet port	Connect to user's monitor port by network wire. Pin definition: Pin4、Pin5: 3.3V、Pin1: TXP; Pin2: TXP; Pin3: REP; Pin6: RXN; Pin11: GND
②	E indicator (red)	On: communication fault
③	C indicator (yellow)	Flicker: communicating
④	R indicator (green)	On: running status
⑤	IN port	Connect to the RS232 port of system monitor card by network wire. Pin definition: Pin4、Pin6: Tx; Pin3、Pin5: Rx; Pin2、 Pin8: 0V; Pin1、Pin7: 5V

System control card

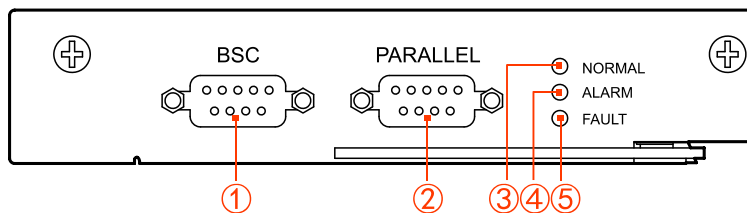

Figure2-14 System control card

Table2-6 Illustration for system control card

NO.	Name	Illustration
①	BSC port	The output double bus control port is used in double bus system to synchronize the output frequency and phase position of each system, which is to ensure the two bus can switch each other.
②	PARALLEL port	Parallel signal port. When several UPS used in parallel system, it needs to use the parallel control wire to connect the parallel port of each UPS in ringlike. When the parallel system has N pieces of UPS, the connection needs N pieces of parallel control wire to ensure every UPS has 2 parallel control wires at least to connect, which is to enhance the reliability of parallel system.
③	NORMAL indicator (green)	On: system control card stay in the status of main card running Flicker: system control card stay in initializing status.
④	ALARM indicator (yellow)	On: there is alarm signal in system control card. Flicker: system control card stay in backup card status.
⑤	FAULT indicator (red)	On: system control card fault

System monitor card

There is a human-machine interactive communication port, 4 input dry contact communication signal and 4 output dry contact signal (as shown in Figure2-15), specific definition is as shown in Table2-7, Table2-8 and Table2-9.

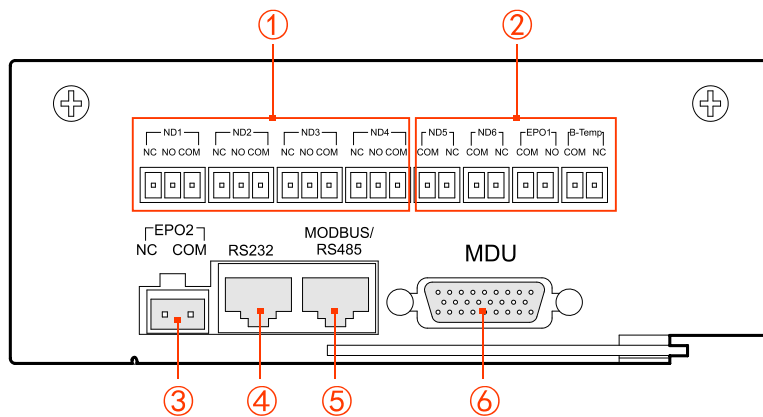

Figure2-15 System monitor card

Table2-7 Illustration for system monitor card

NO.	Name	Illustration
①	Output dry contact	See Table2-8.
②	Input dry contact	See Table2-9.
③	EPO2 input dry contact	External EPO normal closed input port. When NC and COM is open-circuit, the signal is valid. The signal is preset and cannot set.
④	RS232 communication port	It supports RS232 communication. Pin definition: Pin4, Pin6: Tx; Pin3, Pin5: Rx
⑤	MODBUS/RS485 communication port	The communication protocol supports MODBUS RTU or Power Solid standard serial port protocol. It can set switch by touch screen. Pin definition: Pin3、 Pin5: A; Pin4、 Pin6: B
⑥	MDU port	Communication port of touch screen.

- Output dry contact

Table2-8 Function illustration for output dry contact

NO.	Silk-screen	Signal	Function description
1	ND1	UPS FAULT signal	When the signal valid, COM and NO is closed, COM and NC is opened. Allowable withstand voltage is 250V/1A. The signal is preset and cannot set.

NO.	Silk-screen	Signal	Function description
2	ND2	LINE FAIL signal	When the signal valid, COM and NO is closed, COM and NC is opened. Allowable withstand voltage is 250V/1A. The signal is preset and cannot set.
3	ND3	BAT. LOW or start generator signal	When the signal valid, COM and NO is closed, COM and NC is opened. Allowable withstand voltage is 250V/1A. The signal can be set to battery low-voltage or start generator, default is battery low-voltage.
4	ND4	Bypass fault or output overload signal	When the signal valid, COM and NO is closed, COM and NC is opened. Allowable withstand voltage is 250V/1A. The signal can be set to bypass fault or output overload, default is bypass fault.

- Input dry contact

Table2-9 Function illustration for input dry contact

NO.	Silk-screen	Signal	Function description
1	ND5	External maintenance bypass switch or mains power down	When NO and COM is short-circuit, the signal is valid. The signal can be set to external maintenance bypass switch or mains power down, default is external maintenance bypass switch.
2	ND6	Battery switch	When NO and COM is short-circuit, the signal is valid. The signal is preset to battery switch and cannot set.
3	EPO1	External EPO normal open input port	When NO and COM is short-circuit, the signal is valid. The signal is preset and cannot set.
4	B-Temp	Battery temperature detection	Connect with optional battery temperature sensor. It is used to measure the battery temperature.

2.6 Alarm Function

Once the UPS abnormal, it will send sound & light alarm. The alarm or protection function of the UPS is as shown in Table2-10.

Table2-10 Abnormal status and alarm/ protection function

Alarm action	Protection action	Fault name	
Buzzer long beeps	Shut down all inverter output and bypass output.	EPO enable	
		Bypass overload protection	
		Bypass output under-voltage	
	Shut down all inverter output and turns to bypass output.		Inverter output over-voltage
			Inverter output under-voltage
			Inverter overload protection
			Parallel system sovereignty fault
			Parallel system communication abnormal
	Buzzer beeps apace	It is not allowed to supply power by battery or charge battery	Battery over-voltage
			Battery circuit abnormal
None		Battery backup time is not enough.	
None		Output overload alarm.	
Buzzer beeps apace, the red BATT. LOW indicator on.	None	Battery low-voltage alarm	
Buzzer beeps slowly	None	Output circuit abnormal.	
		Output current DC component is too large.	
		Fan is about to use up	
		Busbar capacitance is about to use up.	

Alarm action	Protection action	Fault name
		System card redundancy.
		Environment temperature is too high.
		Power module without redundancy
		Generator startup failure
		Generator shutdown failure
		Communication fault.
		BMS communication fault.
		The communication of cabinet inner busbar 1 abnormal.
		The communication of cabinet inner busbar 2 abnormal.
		The communication of cabinet inner busbar 3 abnormal.
		BSC synchronization wire abnormal.
		Battery low-temperature alarm.
		The static startup is not allowed.
	INV software version is inconformity.	
	System control card X- software version is inconformity.	
	The parallel address repeated.	
	Module amount is inconsistent.	
	Cabinet amount is inconsistent.	
	Bypass output is not allowed.	Bypass power down.
		Bypass over-voltage.
		Bypass under-voltage.
Bypass over-frequency.		
Bypass under-frequency.		
Bypass phase sequence is wrong.		

Alarm action	Protection action	Fault name
		Bypass lack-phase.
		Bypass module off-line.
	ECO output is not allowed.	ECO voltage out of range.
		ECO frequency out of range.
	Mains power supply is not allowed.	Mains power down.
		Mains over-voltage
		Mains under-voltage
		Mains voltage unbalance is too large.
		Mains over-frequency
		Mains under-frequency
		Mains phase sequence is wrong.
		Mains lack-phase
		Mains over-current
		Mains current DC component is too large.
	It turns to float charge. The charge current-limiting value will be set to 0.05C	Battery high-temperature alarm.
	Charging is not allowed.	Battery over-temperature.



CAUTION

After the protection for battery under-voltage, once mains recover to normal power supply, the UPS will restart and charge the batteries.

3 Installation

This chapter mainly introduces the installation of the UPS, including unpacking and checking, installation procedure, installation preparation, mechanical installation and system checking and test, etc.



CAUTION

The UPS installation should be performed by authorized person who is special trained and achieve the qualification of high-voltage and AC power.

The UPS is just suitable for installing on the concrete or nonflammable surface.

3.1 Installation Procedure

The installation procedure of PS series modular UPS is as shown in Figure3-1.

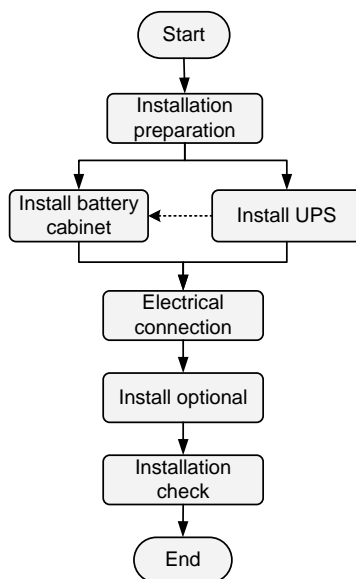

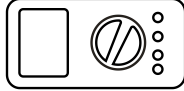

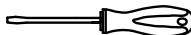





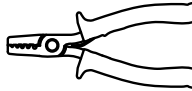
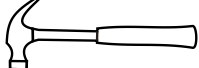
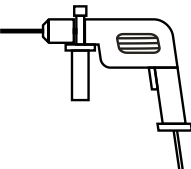
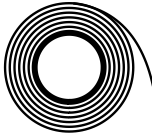
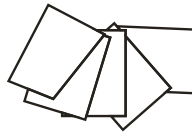

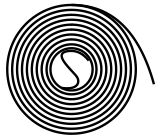
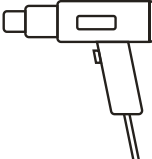

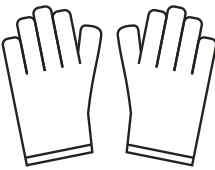
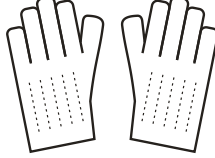
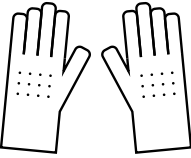



Figure3-1 Installation procedure

3.2 Installation Preparation

3.2.1 Installation Tools

Tools			
			
Clamp meter	Multi-meter	Label paper	Phillips screwdriver
			
Flat-head screwdriver	Socket wrench	Adjustable wrench	Torque wrench
			
COAX crimping tool	Diagonal pliers	Wire stripper	Claw hammer
			
Hammer drill	Insulation tape	Cotton cloth	Brush
			
Heat shrink tubing	Heat gun	Electrician's knife	Protective gloves
			
ESD gloves	Insulated gloves	Hydraulic pliers	Cable tie

**CAUTION**

The installation tools should be with isolated operation to avoid electric shock.

3.2.2 Installation Environment

- Do not install the UPS in the place where exceeds the provision of technology index (temperature: 0°C~40°C, relative humidity: 0%~95%).
- It is strictly prohibit installing the UPS in the environment with metal conductive dust.
- Do not install the UPS in the open air, and the installation environment should meet the provision requirements.
- Basic requirements for power supply:
 - Grounding preparation. Ensure that the grounding terminal is OK and the voltage between neutral wire and grounding wire should not exceed 5V.
 - Before installation, please ensure that the AC input voltage and mains input wire capacity meet the UPS requirements, and considering if there has current-carrying capacity descending caused by wire aging.
 - The mains input voltage range of the UPS is 80~280VAC. The mains capacity should be greater than the max. input power of the UPS.
 - The selected breaker should not with leakage current protection.
- The installation environment of the UPS should be with good ventilation, and far away from water source, heat source and inflammable and explosive objects. Avoid installing the UPS in the place where has direct sunshine, dust, volatile gas, corrosive objects or high salt.

**CAUTION**

The optimal operating temperature for batteries is 20–30°C. Operating at temperatures lower than 20°C will shorten the battery backup time, and operating at temperatures higher than 30°C will shorten the battery lifespan.

Make sure that the external DC distribution circuit is configured with a bipolar disconnecting switch.

3.2.3 Installation Space

Maintain a clearance of at least 800mm from the front panel, side pane or rear panel of the UPS to the wall or adjacent device, and maintain a clearance of at least 500mm from the top of the UPS to ceiling, which is to ensure good ventilation, as shown in Figure3-2.

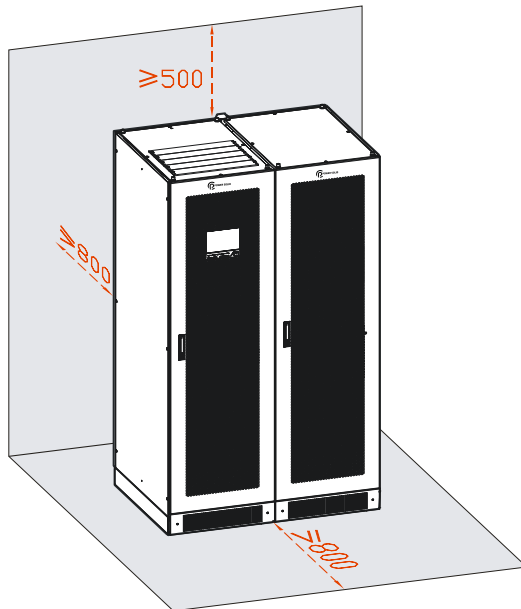

Figure3-2 Installation space (unit: mm)

NOTE

The installation space requirement for the UPS is the same, in above figure, we take PS400KVA as an example to illustrate.

- Avoid any object block the ventilation hole on the front panel and rear panel, which is to keep good ventilation for the UPS, or, it may rise the inner temperature, even influence the UPS service time.

3.2.4 Input and Output Wire Selection

For the wire sectional area selection of AC input and output wires, please refer to Table3-1, Table3-2 for corresponding recommended values, and choose upwards.

Table3-1 Wire and terminal specification recommendation value (the power of single power module is 25kVA)

Model		PS75KVA	PS125KVA	
System max. capacity (kVA)		75	125	
AC input	AC input current (A)	142	236	
	Recommended wire diameter (mm ²)	U/V/W/N	4×50	4×120
	Wire terminal model	DT50	DT120	
Bypass input	Bypass input current (A)	114	189	
	Recommended wire diameter (mm ²)	U/V/W/N	4×35	4×95
	Wire terminal model	DT35	DT95	
Output	Output current (A)	114	189	
	Recommended wire diameter (mm ²)	U/V/W/N (for non-linear load, it needs to increase the wire diameter of neutral wire)	4×35	4×95
	Wire terminal model	DT35	DT95	
Battery input	Nominal discharge current of storage battery (the current of equipped ±20 pieces of 12V storage battery (480V))(A)	166	277	
	Max. discharge current of storage battery (the ending discharge current value <the voltage of each battery is 10.5V> for equipped ±20 pieces of 12V storage)(A)	190	316	
	Recommended wire diameter (mm ²)	+N/-	3×70	2×(3×70)
	Wire terminal model	DT70	DT70	
Grounding wire	Recommended wire diameter (mm ²)	PE	25	50
	Wire terminal model		DT25	DT50

Table3-2 Wire and terminal specification recommendation value (the power of single power module is 50kVA)

Model		PS200KVA,PS300KVA, PS400KVA, PS500KVA, PS600KVA					
System max. capacity (kVA)		200	300	400	500	600	
AC input	AC input current (A)	349	523	697	871	1045	
	Recommended wire diameter (mm ²)	U/V/W/N	2 × (4 × 95)	2 × (4 × 120)	2 × (4 × 185)	2 × (4 × 240)	3 × (4 × 240)
	Wire terminal model	DT-95	DT-120	DT-185	DT-240	DT-240	
Bypass input	Bypass input current (A)	303	455	606	758	909	
	Recommended wire diameter (mm ²)	U/V/W/N	2 × (4 × 70)	2 × (4 × 95)	2 × (4 × 150)	2 × (4 × 185)	3 × (4 × 240)
	Wire terminal model	DT-70	DT-95	DT-150	DT-185	DT-240	
Output	Output current (A)	303	455	606	758	909	
	Recommended wire diameter (mm ²)	U/V/W/N (for non-linear load, it needs to increase the wire diameter of neutral wire)	2 × (4 × 70)	2 × (4 × 95)	2 × (4 × 150)	2 × (4 × 185)	3 × (4 × 240)
	Wire terminal model	DT-70	DT-95	DT-150	DT-185	DT-240	
Battery input	Nominal discharge current of storage battery (the current of equipped ± 20 pieces of 12V storage (480V))(A)	443	664	886	1107	1329	
	Max. discharge current of storage battery (the ending discharge current value <the voltage of each battery is 10.5V> for equipped ±20 of 12V storage)(A)	506	759	1012	1265	1518	

Model			PS200KVA,PS300KVA, PS400KVA, PS500KVA, PS600KVA				
System max. capacity (kVA)			200	300	400	500	600
	Recommended wire diameter (mm ²)	+/N/-	2 × (3 × 120)	2 × (3 × 120)	2 × (3 × 150)	3 × (3 × 185)	3 × (3 × 240)
	Wire terminal model		DT-120	DT-120	DT-150	DT-185	DT-240
Grounding wire	Recommended wire diameter (mm ²)	PE	120	120	150	185	240
	Wire terminal model		DT-120	DT-120	DT-150	DT-185	DT-240

 **NOTE**

The wires prepared by our company have passed the GB or UL certification. The wires quality is excellent, and all meet the production compliance. The cross-sectional areas above are recommended for 5 meters long wires. Longer wires require larger cross-sectional areas.

3.2.5 Surge Protection Device

If the UPS is installed in a lightning-prone area, install multiple surge protection devices between the power grid and the UPS. The UPS installed outdoors requires a higher surge protection level than those installed indoors.

3.2.6 Reverse Feedback Protection (Optional)

It is suggested to add the contactor with 220V AC coil at the AC power distribution side as the reverse feedback protection device.

3.3 Transportation and Unpacking

3.3.1 Transportation

**CAUTION**

The UPS should be transported by trained professional.

During transporting, please take care and avoid impact or falling off.

If the UPS needs to be stored for a long time after unpacking, it is suggested to package the UPS with original plastic bag.

The UPS can be transported by motor-driven forklift (as shown in Figure3-3) or manual forklift (as shown in Figure3-4). While lifting, please keep the UPS center of gravity at that of the forklift and move slowly and stably.



Figure3-3 Motor-driven forklift

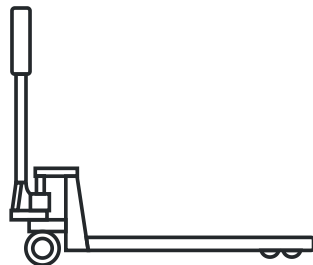

Figure3-4 Manual forklift

**CAUTION**

When lifting, pay attention to the balance and stable of the UPS.

During moving, keep the UPS vertical and do not put down or uplift suddenly.

3.3.2 Unpacking

 **NOTE**

The package of the UPS is similar. Following we take PS400KVA as an example to illustrate.

- Step 1 Check if the package appearance is in good condition and if there has any transportation damage. If any damage, please inform the carrier immediately.
- Step 2 Transport the UPS to assigned site.



CAUTION

To avoid toppling over during transporting, ensure that the end of the forklift arm exceed the wooden bracket.

- Step 3 Unpack the external package. Remove the foam pad and plastic bag, and take out the accessories and built-in documents.
- Step 4 Check the UPS.
- Inspect the appearance of the UPS and check if there has any damage caused by transportation. If any damage, please inform the carrier immediately.
 - Compare with the packing list and check if the accessories mode is complete and proper. If the accessories lack or model wrong, please take note and contact the Power Solid Company or local agency of our company.
- Step 5 If the UPS is OK, dismantle the fasten screws of front and rear cover plate at the bottom of the cabinet (as shown in Figure3-5), by Phillips screwdriver, and then remove the front and rear cover plate.

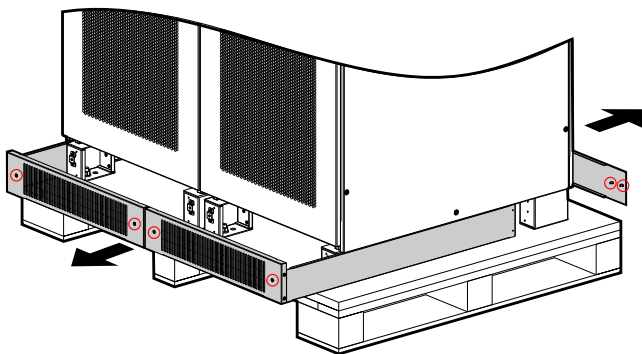

Figure3-5 Dismantle the bottom cover plate

- Step 6 Unscrew the bolts that connected with cabinet and wooden bracket by socket wrench, the bolt position is as shown in Figure3-6.

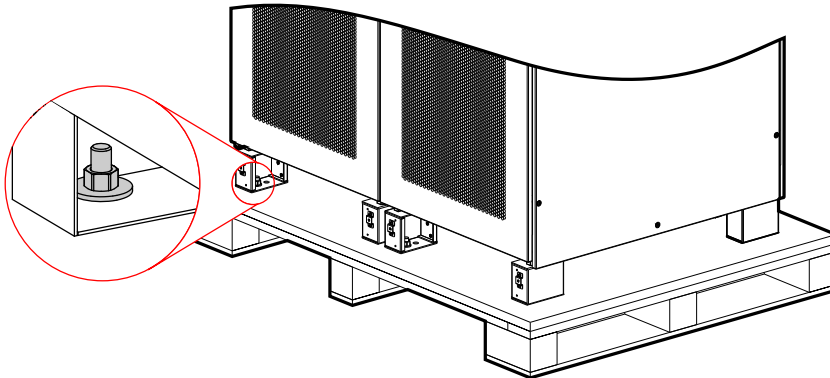

Figure3-6 Bolt position

---End

3.4 Mechanical Installation



NOTE

In this section, we take ground installation as an example to illustrate.



CAUTION

If the UPS is installed on the ground, it is necessary to set the wire groove to connect wires in advance, as shown in Figure3-7.

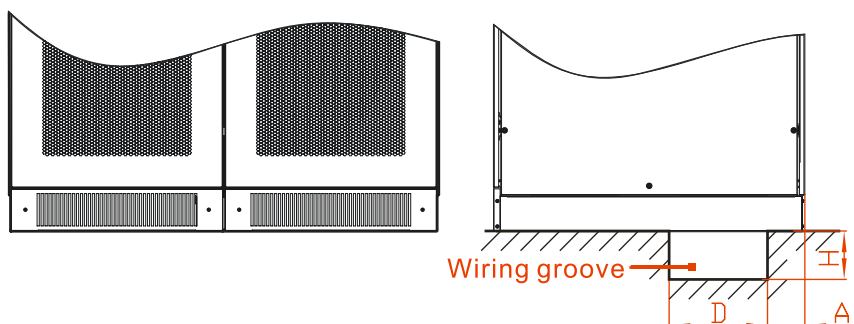

Figure3-7 Wiring groove diagram (unit: mm)

 **NOTE**

The wiring groove requirements of PS series UPS is the same, in above figure, we take PS400KVA as an example to illustrate.

The recommended wiring groove size is as follows: for PS75KVA, PS125KVA, PS200KVA, PS300KVA \times D \times H: 650 \times 200 \times 300(mm); for PS400KVA, PS500KVA, PS600KVA \times D \times H: 245 \times 500 \times 300(mm).

Step 1 Determine and plan the installation position according to the UPS size (as shown in Figure3-8, Figure3-9) and installation clearance requirement (see3.2.3 Installation Space).

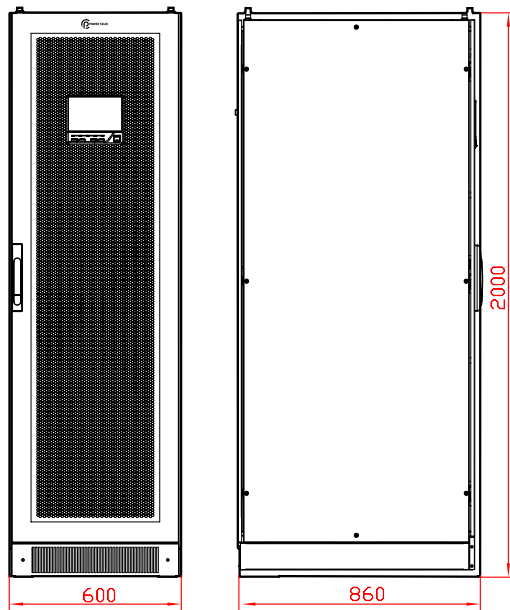

Figure3-8 Size of PS75KVA, PS125KVA, PS200KVA, PS300KVA

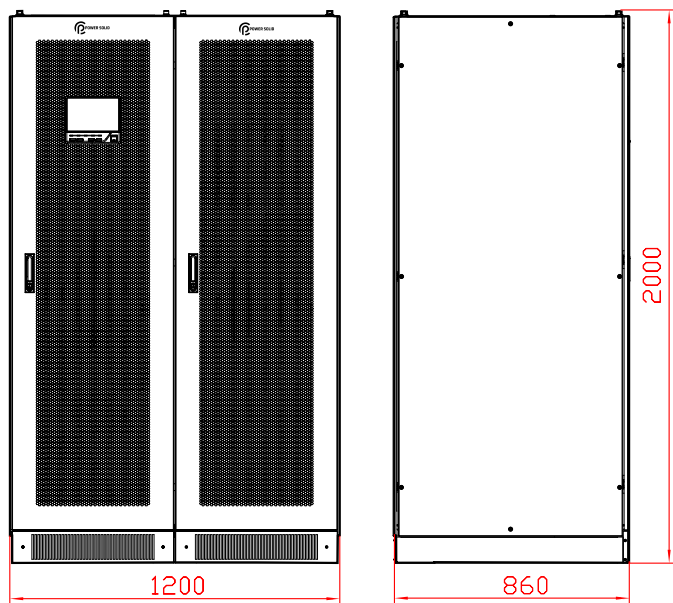

Figure3-9 Size of PS400KVA, PS500KVA, PS600KVA

Step 2 Drill 4 holes (hole diameter is $\phi 13$) by hammer drill according to the bottom installation hole size (as shown in Figure3-10, Figure3-11).

 **NOTE**

If the UPS is installed on U-steel, drill 4 hole (hole diameter is $\phi 14$) on the U-steel directly, and then perform Step 4 directly.

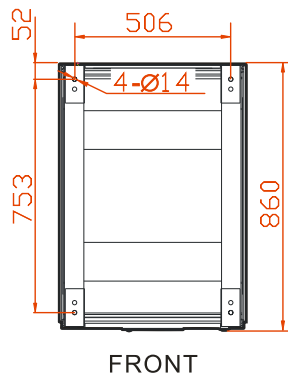

Figure3-10 Bottom size of PS75KVA,PS125KVA, PS200KVA, PS300KVA (unit: mm)

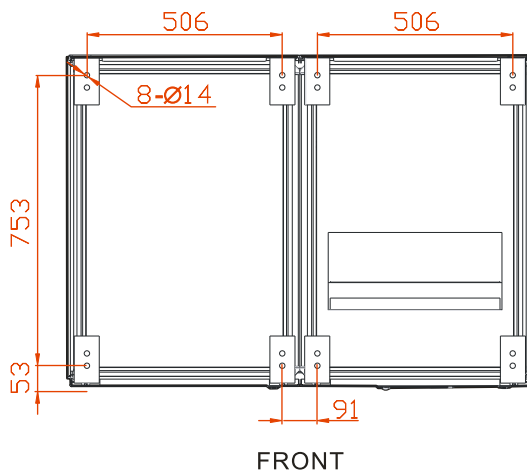
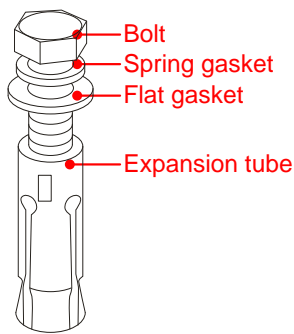

Figure3-11 Bottom size of PS400KVA, PS500KVA, PS600KVA (unit: mm)

Step 3 Install expansion bolts. The structure and installation for the expansion bolt is as shown in Figure3-12.



1. Drill holes on the installation ground by hammer drill.
2. Tighten The expansion bolts mildly, and put it to the hole vertically, and then knock the expansion bolt by rubber hammer till all the expansion tube into the hole.
3. Pre tighten the expansion bolt.
4. Screw out the bolt , take down the spring gasket and flat gasket.

Figure3-12 Expansion bolt structure and installation

**CAUTION**

Take whole expansion tube into the hole as standard of expansion bolt installation depth. Expansion tube should not higher than ground, which is to avoid effect the following cabinet installation.

**NOTE**

The outer height of expansion bolts should be within the range of 30-50mm.

- Step 4 Move the UPS from wooden bracket to the ground, and align the bottom installation hole at the expansion bolt, lock the bolts.

**CAUTION**

When moving PS75KVA, PS125KVA, PS200KVA, PS300KVA UPS by forklift, the forklift arm must be inserted from side direction.

When moving PS400KVA, PS500KVA, PS600KVA UPS by forklift, the forklift arm must be inserted from front or back direction.

During transporting, please ensure that the UPS center of gravity locate at the centre of forklift arms, which is to avoid UPS tilting.

**NOTE**

If the wiring of the UPS is from bottom, please ensure that the installation position is right above the wiring groove.

- Step 5 Install the bottom cover plates, and then finish the UPS installation.

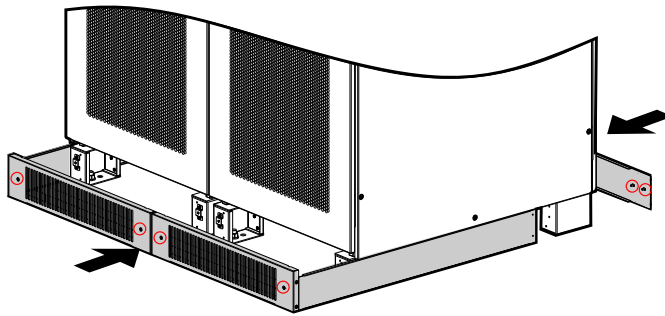

Figure3-13 Install bottom cover plates of PS400KVA, PS500KVA, PS600KVA

----End

3.5 System Wiring

There are two types of PS75KVA、PS125KVA、PS200KVA、PS300KVA UPS with up and bottom wiring. The PS400KVA、PS500KVA、PS600KVA UPS are compatible with top and bottom wiring.

3.5.1 PS75KVA, PS125KVA(Compatible with top and bottom incoming wires) & PS200KVA, PS300KVA (Bottom wiring)

Step 1 Open the front door and rear door of the cabinet, as shown in Figure3-14.

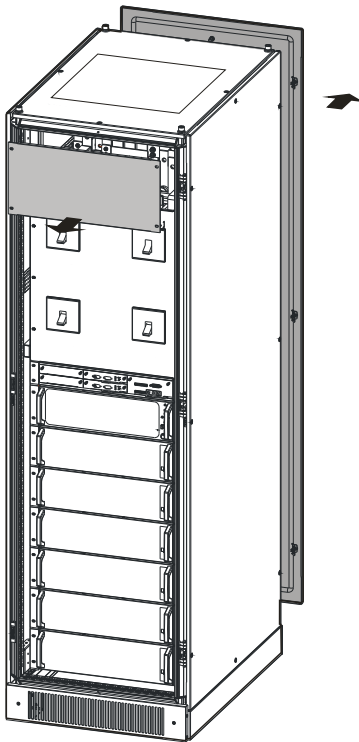

Figure3-14 Remove the sealing plate schematic diagram

Step 2 Connect the input, output and battery wires according to Figure3-16, and fasten the bolts.

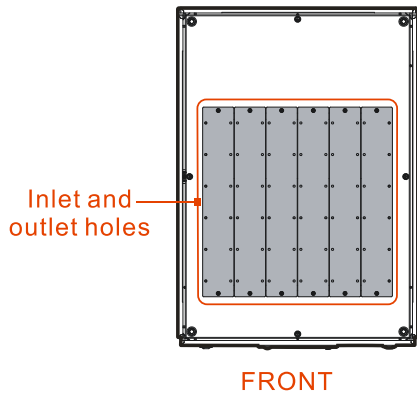

Figure3-15 Inlet and outlet schematic diagram

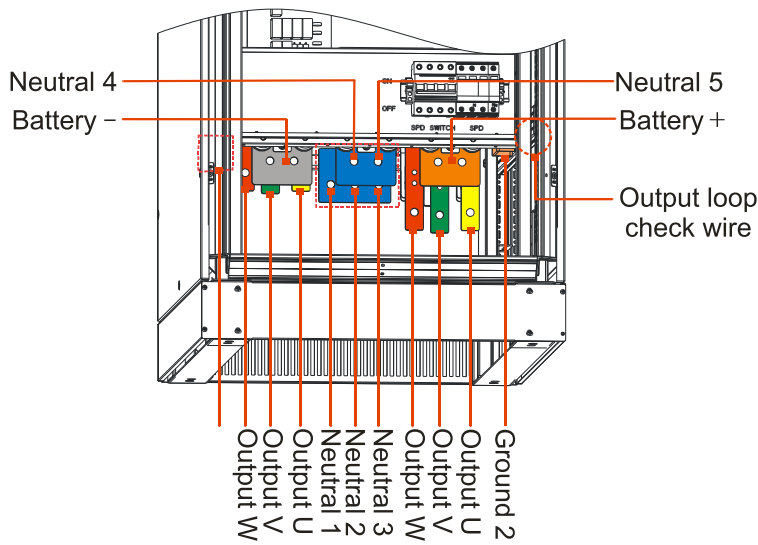

Figure3-16 Wiring terminal



CAUTION

It is suggested to equip DC breaker for battery DC input, specific wire connection is as shown in Figure3-17.

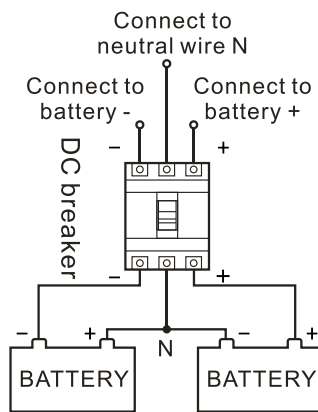

Figure3-17 Battery wire connection diagram

- Step 3 After finishing the wire connection, install the bottom wiring cover plate and fill the empty party with insulation fireproofing mud, then the wiring is completed.

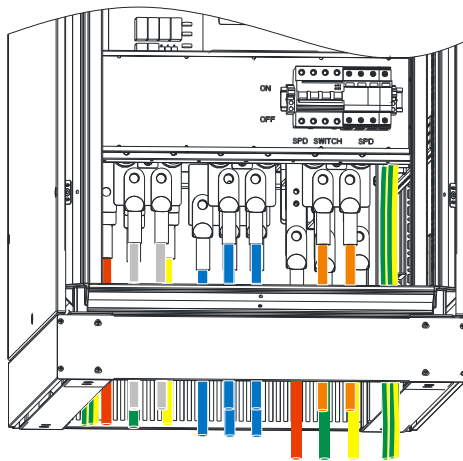

Figure3-18 Wiring diagram

**NOTE**

PS75KVA、PS125KVA UPS are compatible with top and bottom incoming wires, and its wiring diagram as shown in Figure3-19.

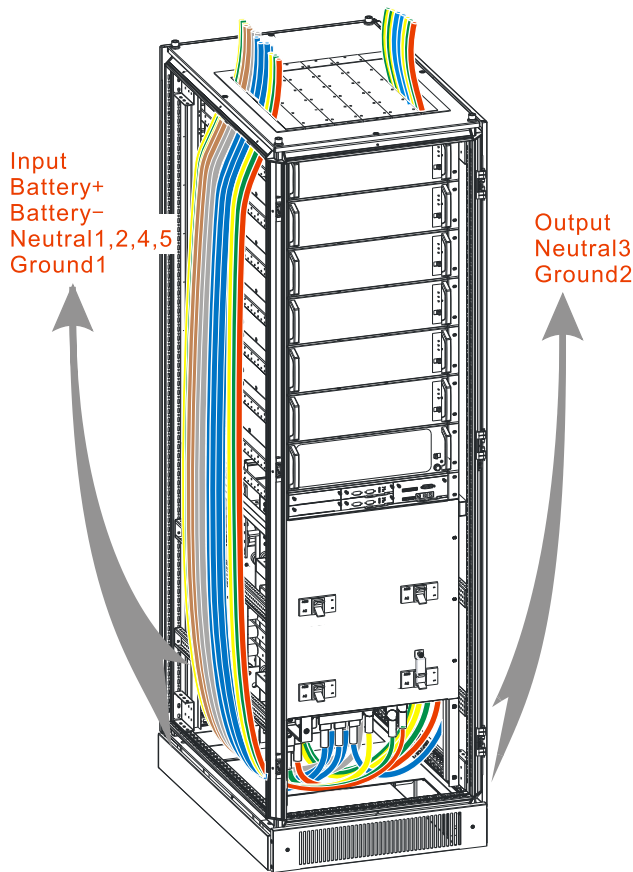

Figure3-19 Wiring diagram of PS75KVA, PS125KVA

NOTE

Input wires, battery negative wires, battery positive wires, neutral wire 1, neutral wire 2, neutral wire 4 neutral wire 5, ground wire 1 of PS75KVA、 PS125KVA (Top wiring) from the left side of the UPS;
 Output wires, neutral wire 3, ground wire 2 of PS75KVA、 PS125KVA (Top wiring) from the right side of the UPS.

----End

3.5.2 PS200KVA, PS300KVA (Top wiring)

NOTE

Refer to Figure3-19 for the specific mode of PS75KVA, PS125KVA (top wiring).

Step 1 Open the front door and rear door of the cabinet, as shown in Figure3-20.

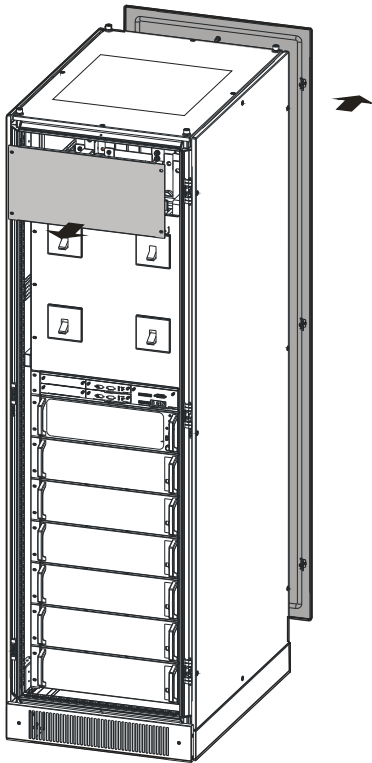

Figure3-20 Remove the sealing plate schematic diagram

Step 2 Connect the input, output and battery wires according to Figure3-21, and fasten the bolts.

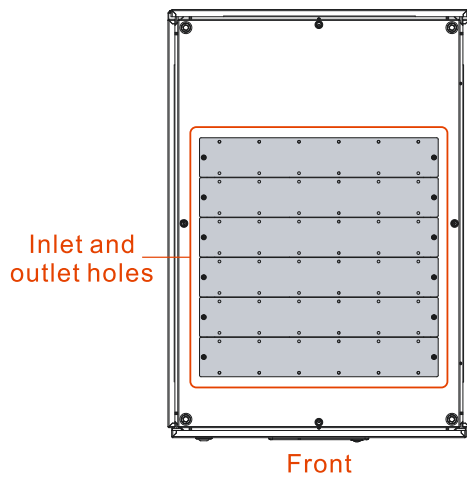

Figure3-21 Inlet and outlet schematic diagram

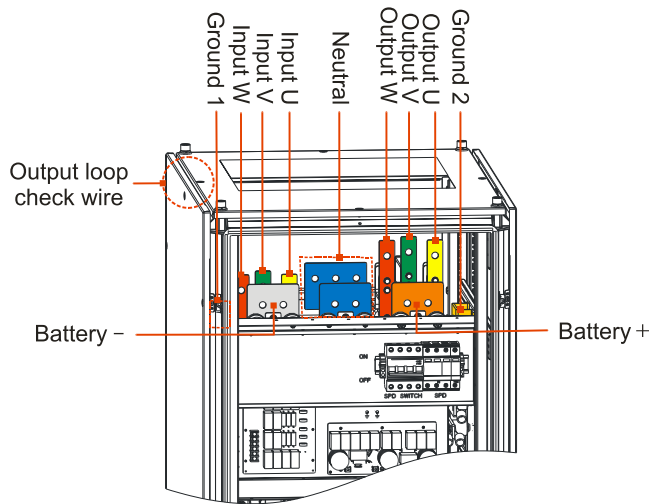

Figure3-22 Wiring diagram



CAUTION

It is suggested to equip DC breaker for battery DC input, specific wire connection is as shown in Figure3-23.

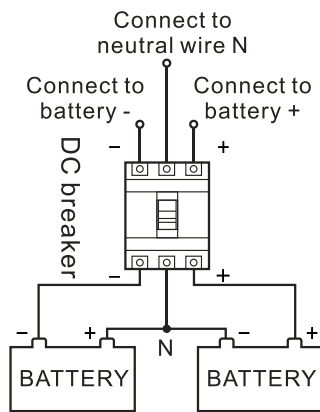

Figure3-23 Battery wire connection diagram

Step 3 After finishing the wire connection, install the top cover, and then the wiring is completed. The wiring diagram is as shown in Figure3-24.

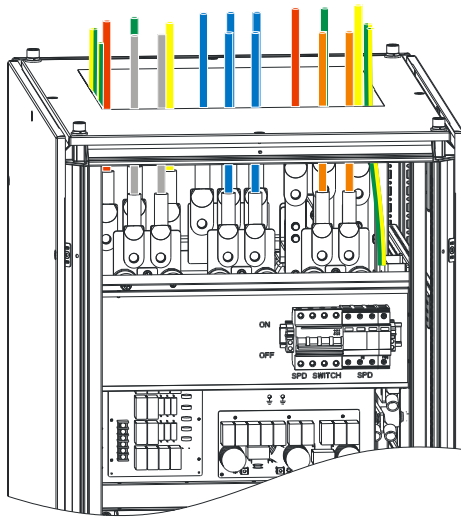

Figure3-24 Wiring diagram of PS200KVA, PS300KVA (top

wiring) ----**End**

3.5.3 PS400KVA, PS500KVA, PS600KVA

- Step 1 Open the front door of distribution cabinet, place the input switch (POWER), output switch (OUTPUT), maintenance switch (MAINTENANCE), bypass switch (BYPASS) to OFF, as shown in Figure3-25.

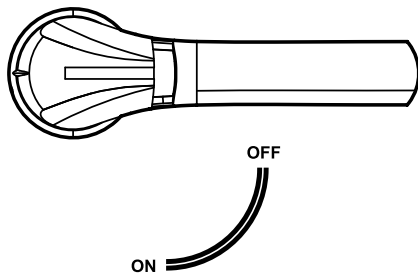

Figure3-25 Place the switch to OFF

- Step 2 Loose the fasten bolts of each cover plate, screw the handle of each switch, and then dismantle the wiring cover plate, as shown in Figure3-26.

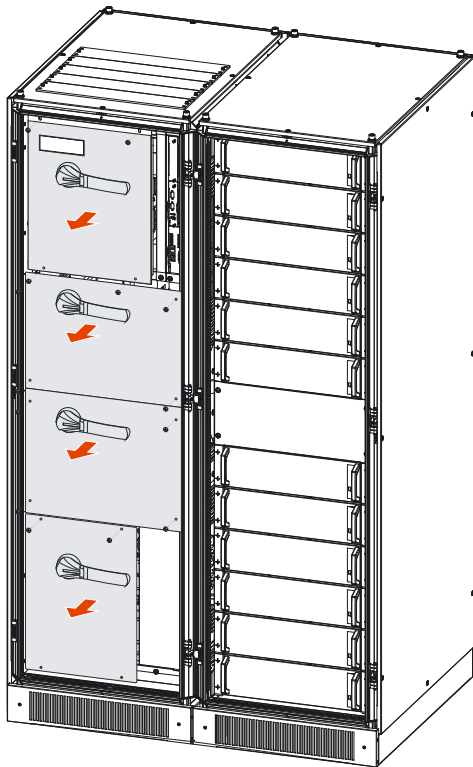

Figure3-26 Dismantle the wiring cover plate of distribution cabinet

Step 3 Connect the input, output and battery wires according to Figure3-27 in proper order, and then fasten the bolts.

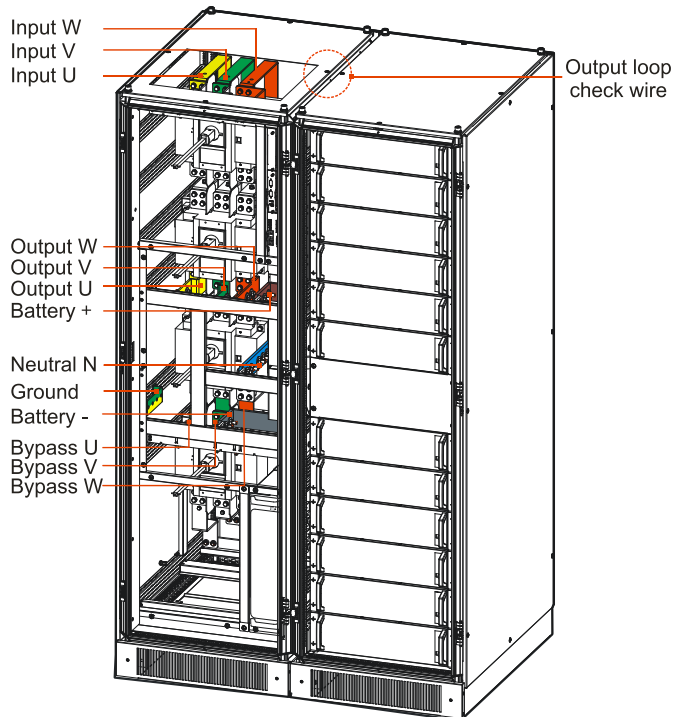

Figure3-27 Wiring terminal of distribution cabinet

 **NOTE**

- If the wiring is from upside, it needs to make the cable go through the top styrofoam, and then connect the cables.
- If the wiring is form downside, it needs to knock down the bottom wiring hole, and then connect the cables.
- After connecting, connect the cables onto the front isolation beam of the cabinet shipshape.



CAUTION

It is suggested to equip DC breaker for battery DC input, specific wire connection is as shown in Figure3-28.

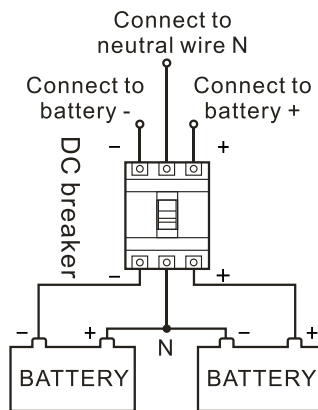

Figure3-28 Battery wire connection diagram



CAUTION

When wiring, ensure that the input, output wires and input, output terminal contact firmly and must not contact bad or wrong.

- Step 4 After wiring, fasten the cables to corresponding epoxy plate by cable tie (as shown in Figure3-29, Figure3-30), and install the wiring cover plate again, and then install the handle of switch. The wiring is finished.

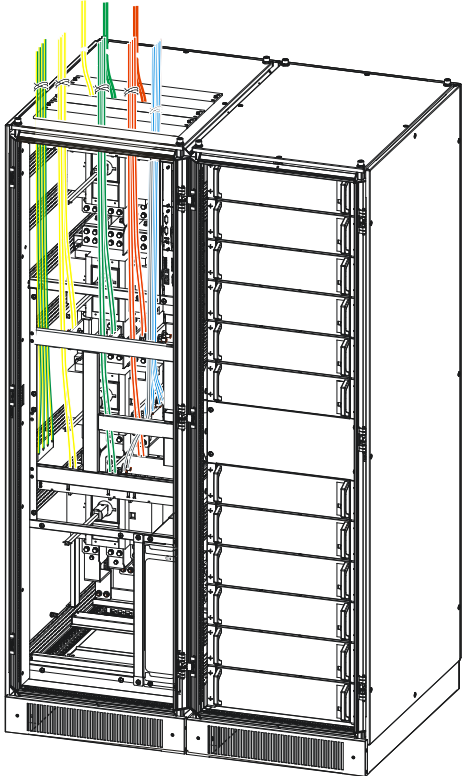

Figure3-29 Wiring diagram of distribution cabinet (top wiring)

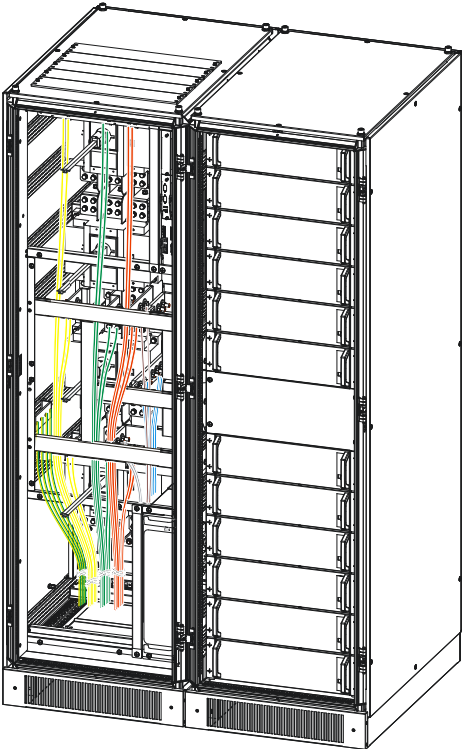

Figure3-30 Wiring diagram of distribution cabinet (bottom wiring)

Step 5 After finish the installation of cover plate, fill the empty part with insulation fireproofing mud.

----End

After finish the assembling, perform the test and then the UPS can be put in use.

3.6 Parallel System Connection

When the wiring of parallel system is needed, please refer to Figure3-31, Figure3-32 to connect the parallel system.

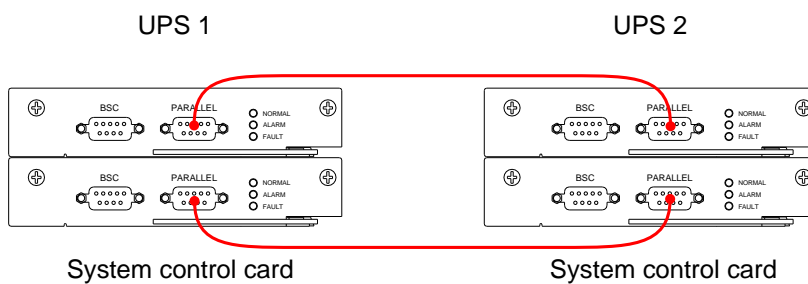

Figure3-31 Parallel system (with 2 UPS) connection

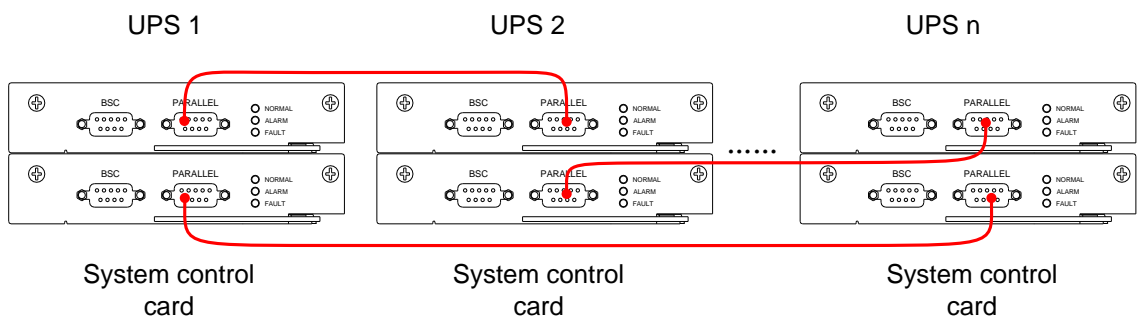

Figure3-32 Parallel system (with several UPS) connection

If there is 2 UPS in parallel system, the wiring way is as follows.

Parallel system connection of PS75KVA, PS125KVA, PS200KVA, PS300KVA (top wiring)

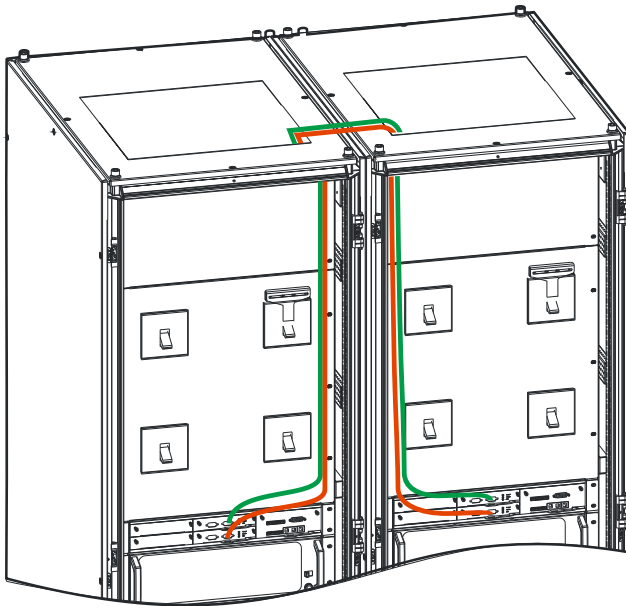

Figure3-33 Parallel system connection diagram of PS75KVA, PS125KVA, PS200KVA, PS300KVA (top wiring)

 **NOTE**

The wire color above is just used to distinguish the different ports, the actual wire color may not be the same as shown in the figure's.

Parallel system connection of PS75KVA, PS125KVA, PS200KVA, PS300KVA(bottom wiring)

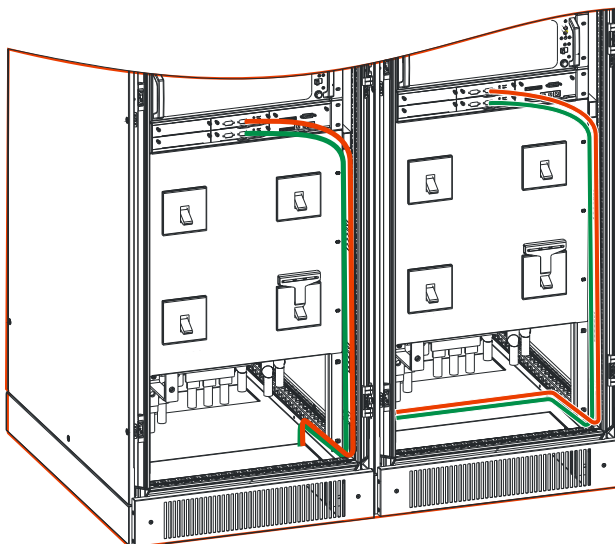

Figure3-34 Parallel system connection diagram of PS75KVA, PS125KVA, PS200KVA, PS300KVA (bottom wiring)

 **NOTE**

The wire color above is just used to distinguish the different ports, the actual wire color may not be the same as shown in the figure's.

Parallel system connection of PS400KVA, PS500KVA, PS600KVA

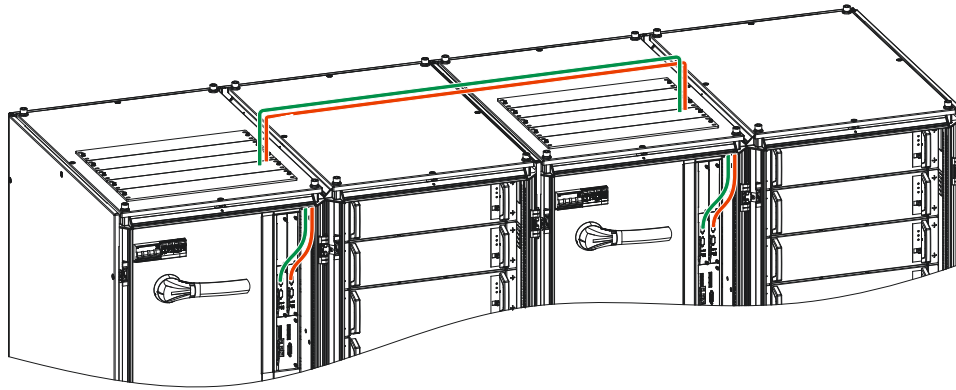

Figure3-35 Parallel system connection diagram of PS400KVA、PS500KVA、PS600KVA (top wiring)

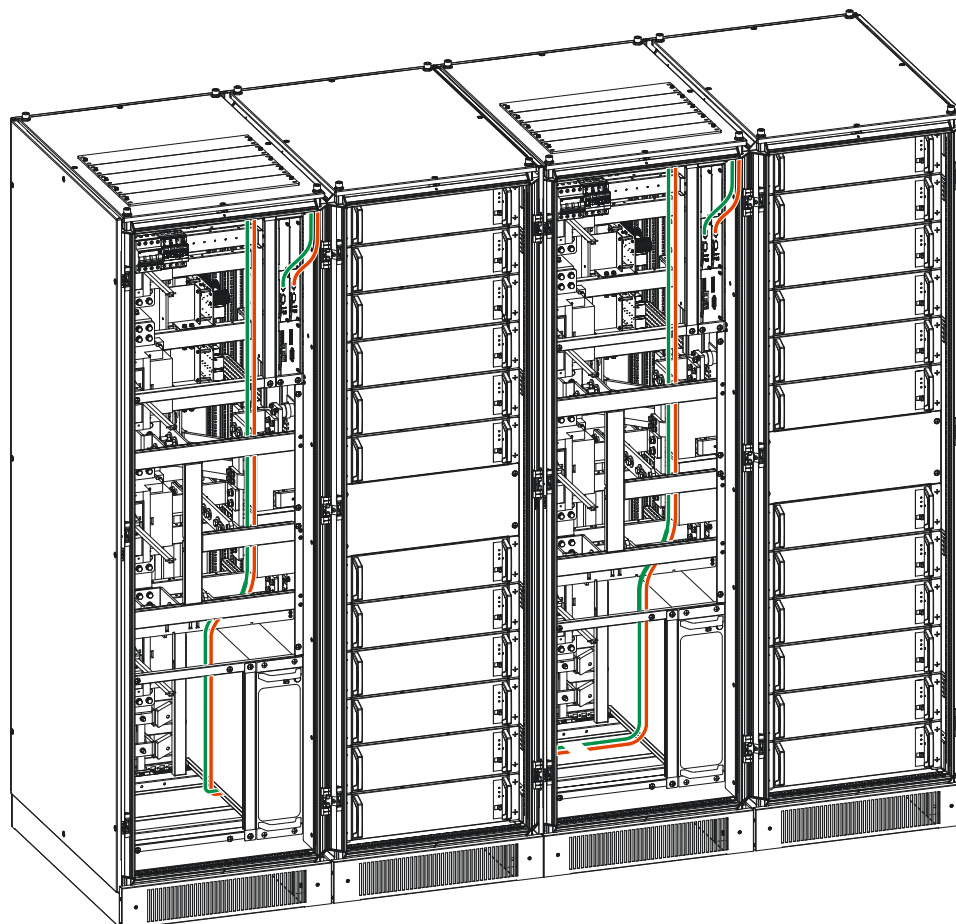

Figure3-36 Parallel system connection diagram of PS400KVA、PS500KVA、PS600KVA (bottom wiring)

 **NOTE**

The parallel system connection of PS400KVA, PS500KVA, PS600KVA is the same, in this section, we take PS400KVA as an example to illustrate.

3.7 System Check and Test

3.7.1 Check Electrical Connection

After finishing the electrical connection, check the following items.

Table3-3 Check list

No.	Check item	Result
1	Check if the color of AC cables is in accordance with the specification.	Yes <input type="checkbox"/> No <input type="checkbox"/>
2	Check if the wiring of the UPS is firmly.	Yes <input type="checkbox"/> No <input type="checkbox"/>
3	Check if the safety identification of AC power distribution unit is complete.	Yes <input type="checkbox"/> No <input type="checkbox"/>
4	Check if the wire connection point is firmly.	Yes <input type="checkbox"/> No <input type="checkbox"/>
5	Check if the battery is connected in right polarity and sequence.	Yes <input type="checkbox"/> No <input type="checkbox"/>
6	Check if the cable identification is correct.	Yes <input type="checkbox"/> No <input type="checkbox"/>
7	Check if the wiring is neat and the cable connection is in accordance with the specification.	Yes <input type="checkbox"/> No <input type="checkbox"/>
8	Check if the UPS installation and wiring is advantageous to the transformation, expansion and maintenance in the future.	Yes <input type="checkbox"/> No <input type="checkbox"/>
9	Check if the UPS has any foreign matter. (such as the back of module, top of UPS, wiring terminal row, switch and so on)	Yes <input type="checkbox"/> No <input type="checkbox"/>

3.7.2 UPS Test

Turn off the mains input switch to simulate the situation of mains fault. When mains fault, the UPS turns to battery inverter, the touch screen will show the alarm and the buzzer will beep every 1s.

3.7.3 Connect Load

After the UPS starting and working stably, turn on the load. Start big-power devices before small-power ones. Some devices has large starting current which may cause overload protection (or bypass operation), it is better to start these equipment before others.

4 Touch Screen Operation and Setting

This chapter mainly introduces the work parameters and work status and system setting of the UPS.

4.1 Menu Structure

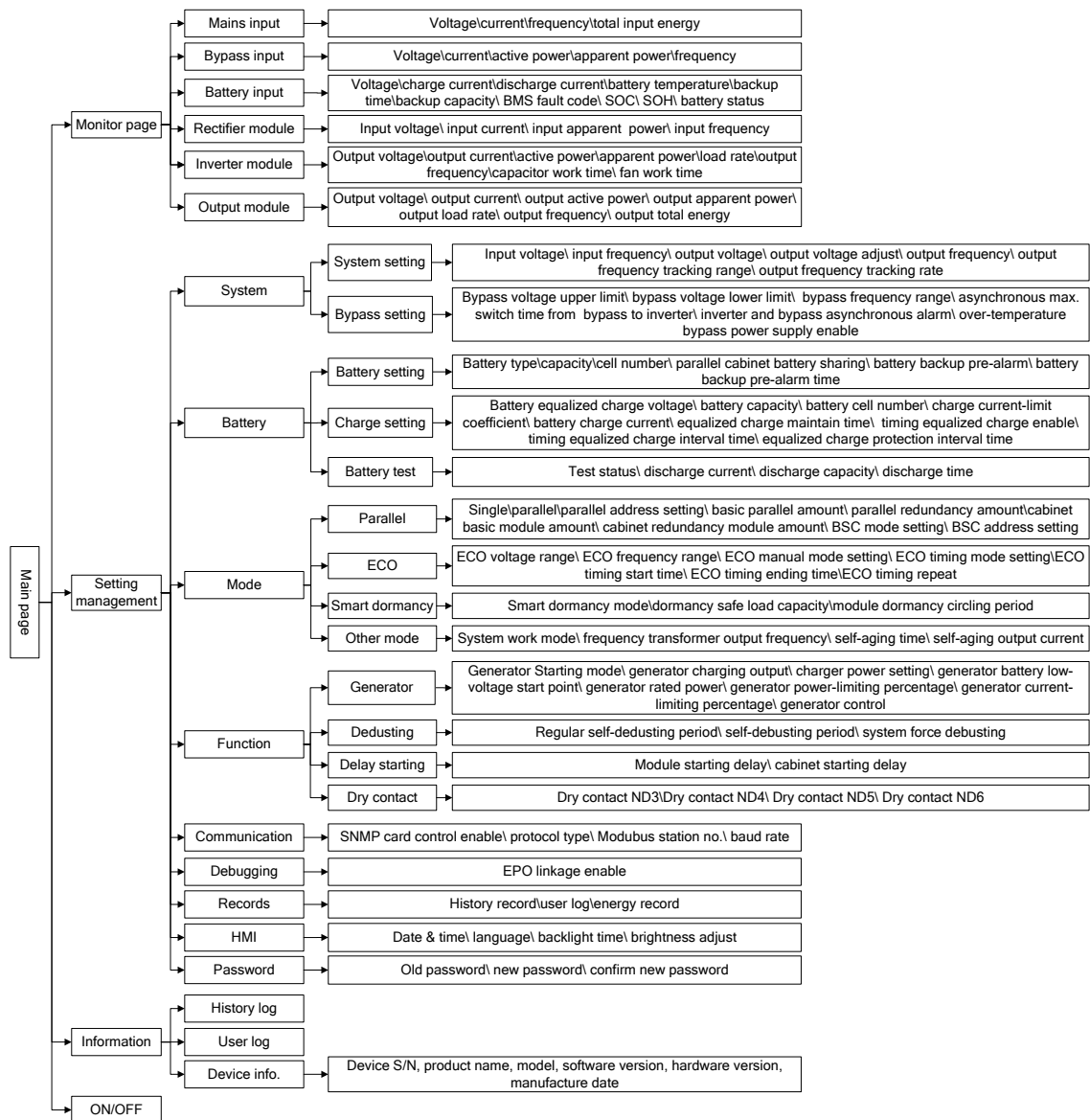

Figure4-1 Menu structure

 **NOTE**

The value in the figures of this chapter is just for illustration, for real page please see the actual achieved product.

4.2 Main Page

After powering on, it will enter system monitor main page, as shown in Figure4-2.

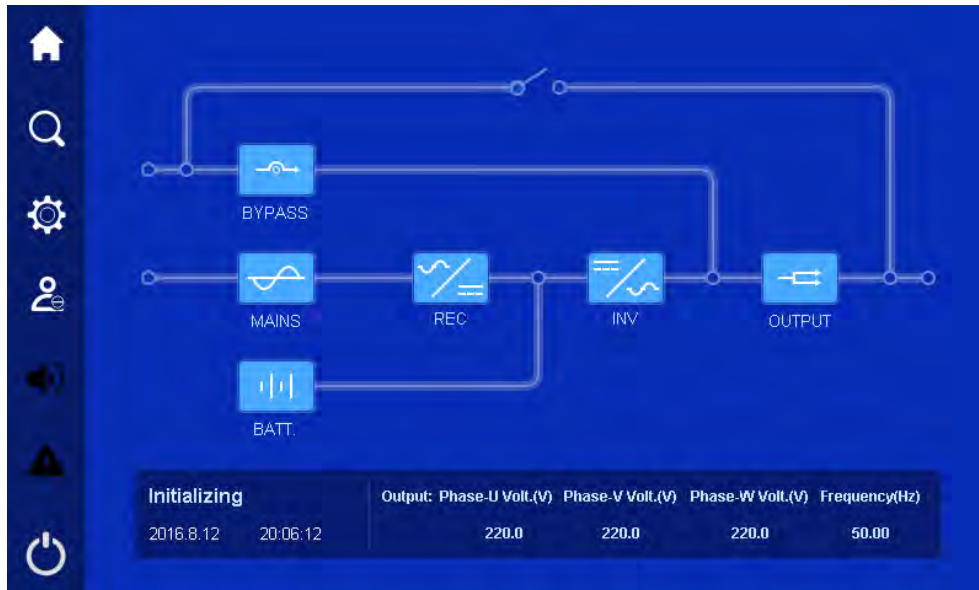







Figure4-2 Monitor main page

After entering the main page, user can monitor the system conveniently. The icon meaning on the main page is as follows.

: System bypass input. When bypass input abnormal, the icon flickers and shows as .

: System mains input. When mains input abnormal, the icon flickers and shows as .







: Rectifier information. Click the icon, you can select and check the rectifier information of each module.

: Inverter information. Click the icon, you can select and check the inverter information of each module.

: Battery status. When battery abnormal, the icon flickers and shows as .

: System output. When output abnormal, the icon flickers and shows as .

: Back to main page.

- : Information record.
- : System parameter setting.
- : Login.
- : Buzzer control.
- : Alarm.
- : ON/OFF.

The work status and energy flow on the main page shows the system running status and module running condition directly.

4.3 System Work Status Display

The system work status includes: initializing, fault protection, shutdown, exit parallel system, bypass output, inverter output, grid-connected aging, ECO bypass output, frequency conversion INV. output, maintenance bypass output, grid-connected aging off. Each interface is as shown from Figure4-3 to Figure4-14.

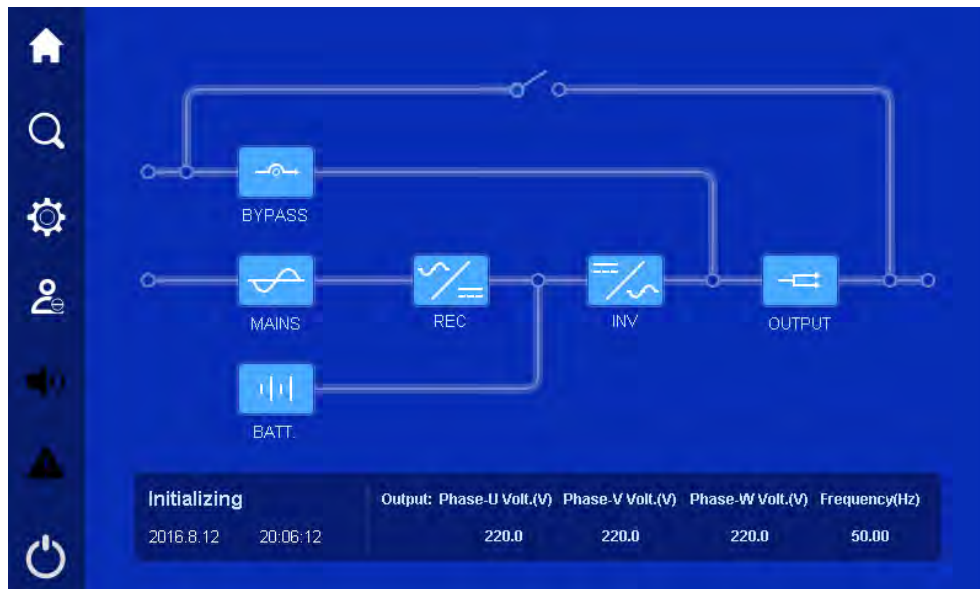

Figure4-3 Initializing

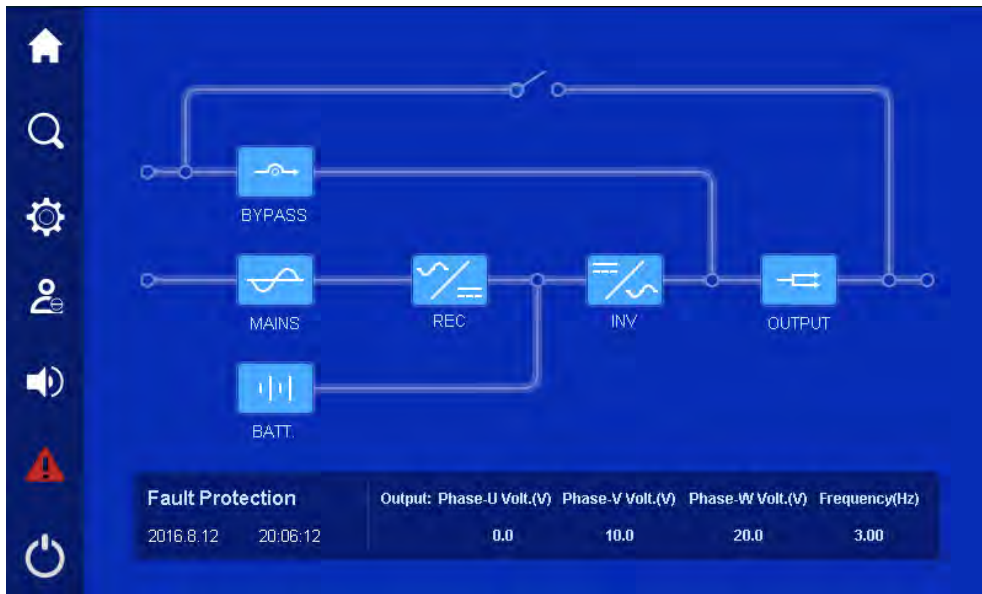

Figure4-4 Fault protection, with no output

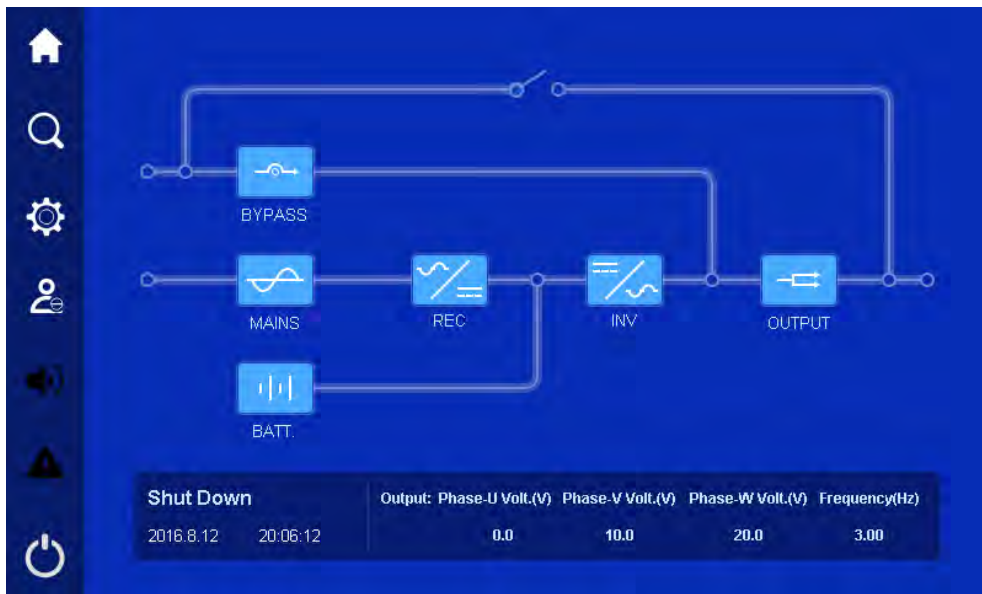

Figure4-5 Shutdown

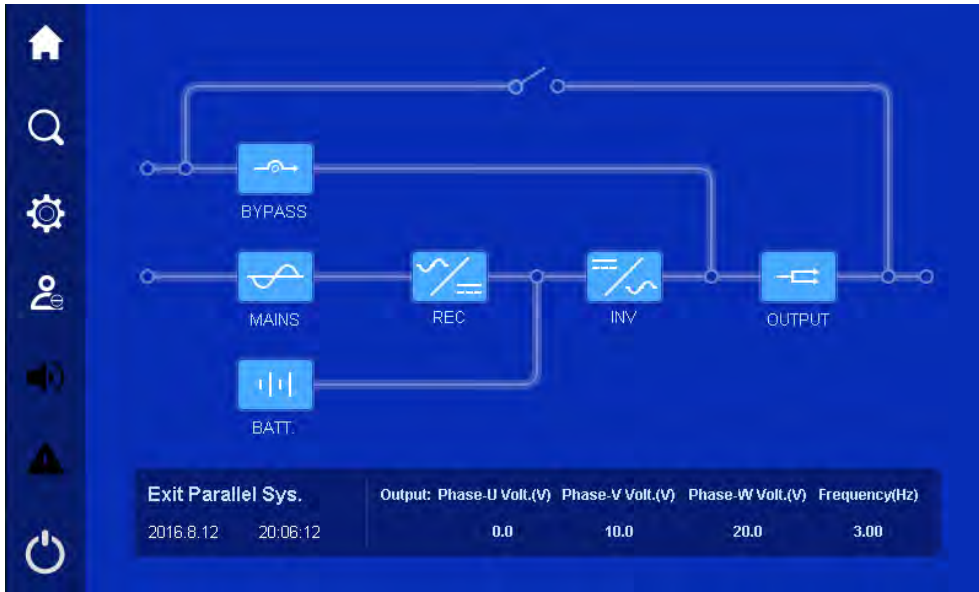

Figure4-6 Exit parallel system

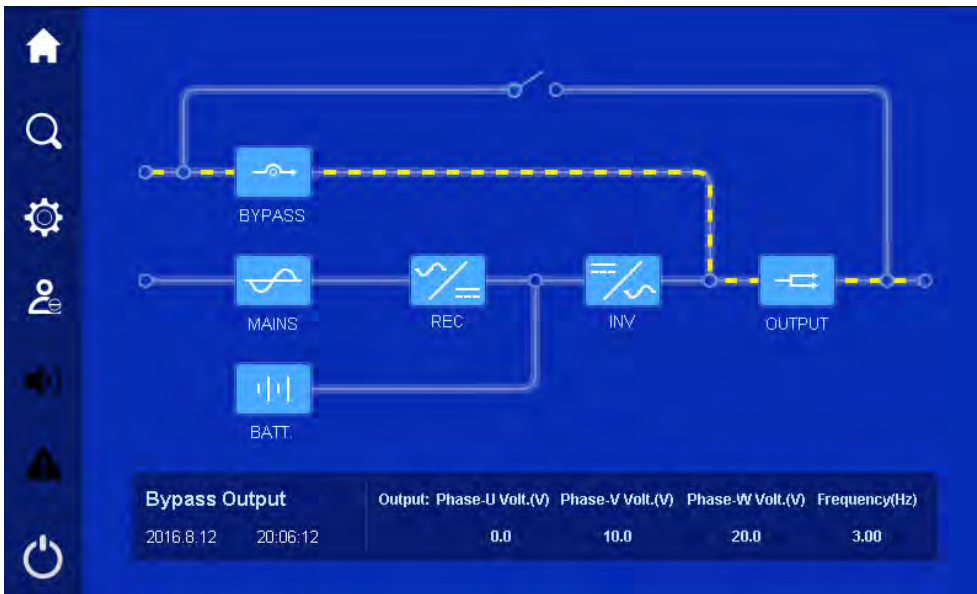

Figure4-7 Bypass output

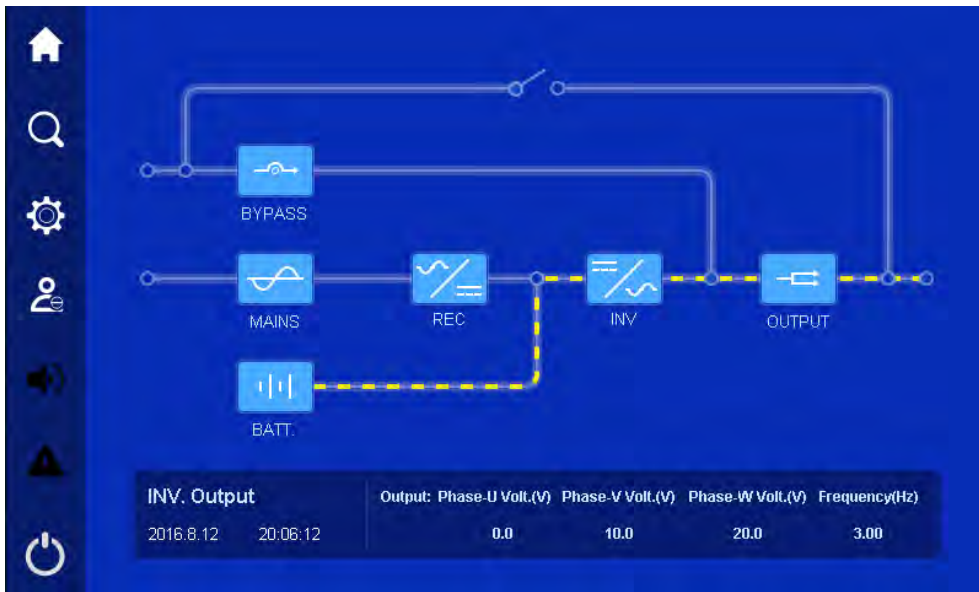

Figure4-8 Battery INV. output

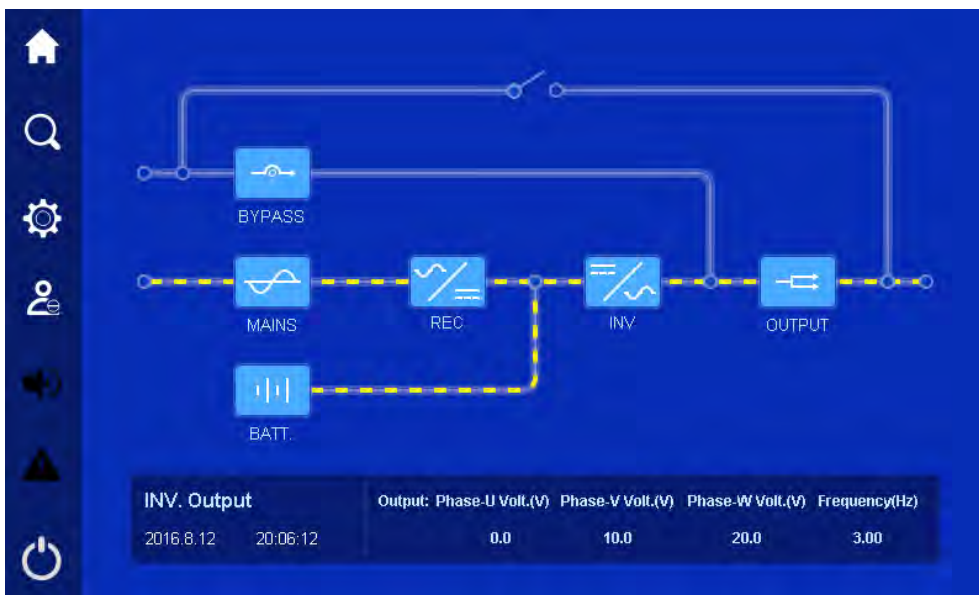

Figure4-9 Mains INV. output

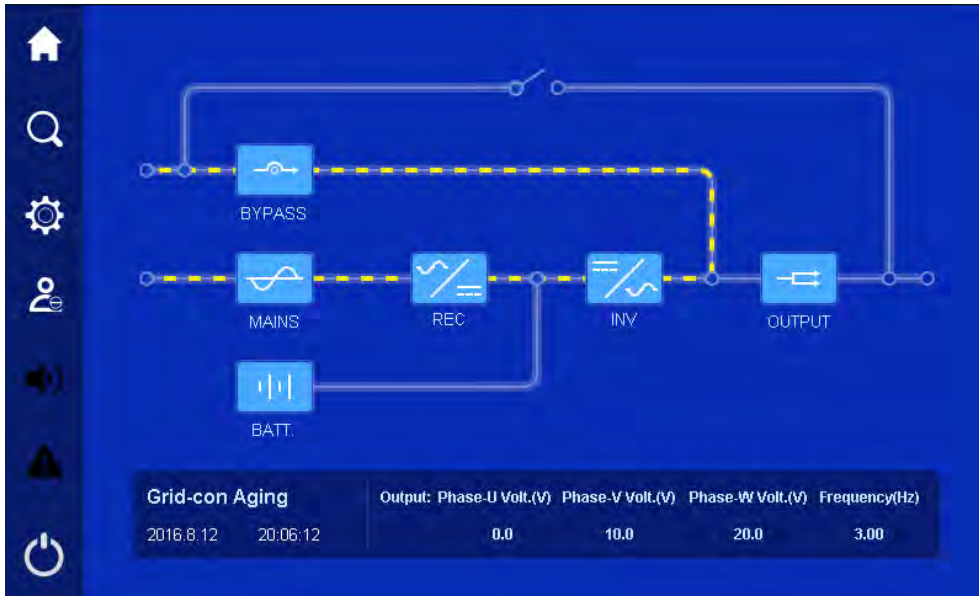

Figure4-10 Grid-connected aging running

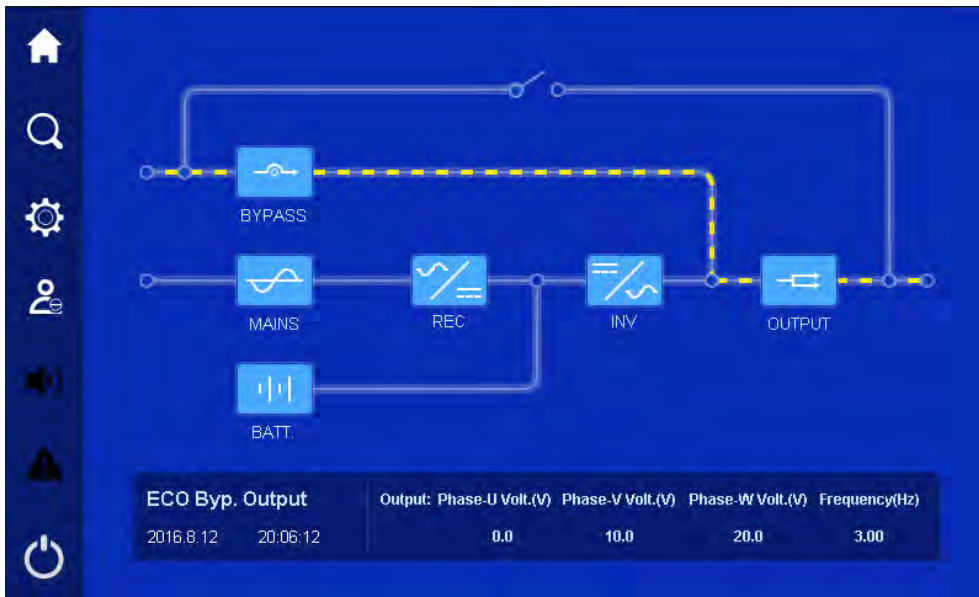

Figure4-11 ECO bypass output

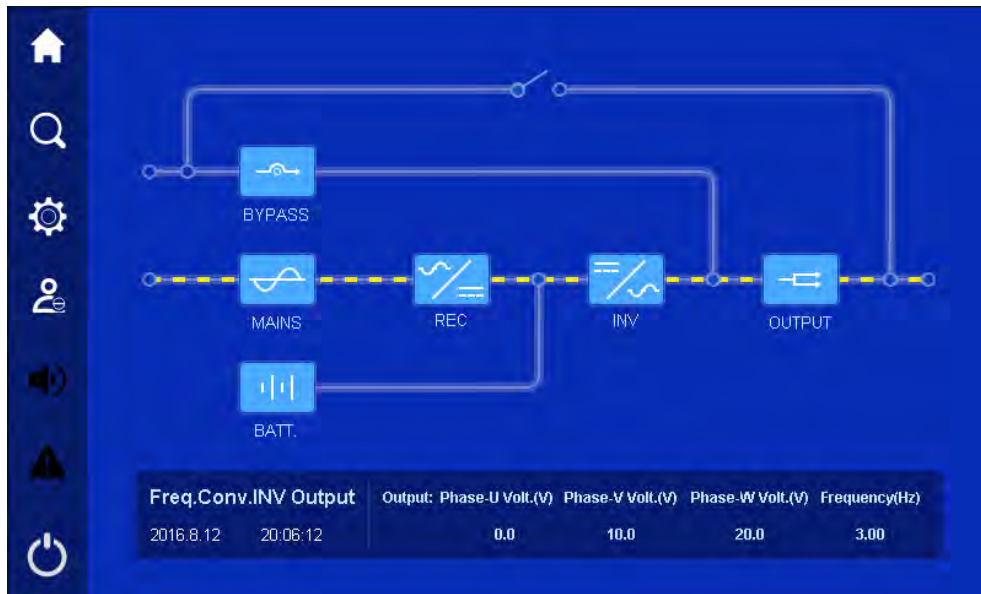

Figure4-12 Frequency conversion INV. output

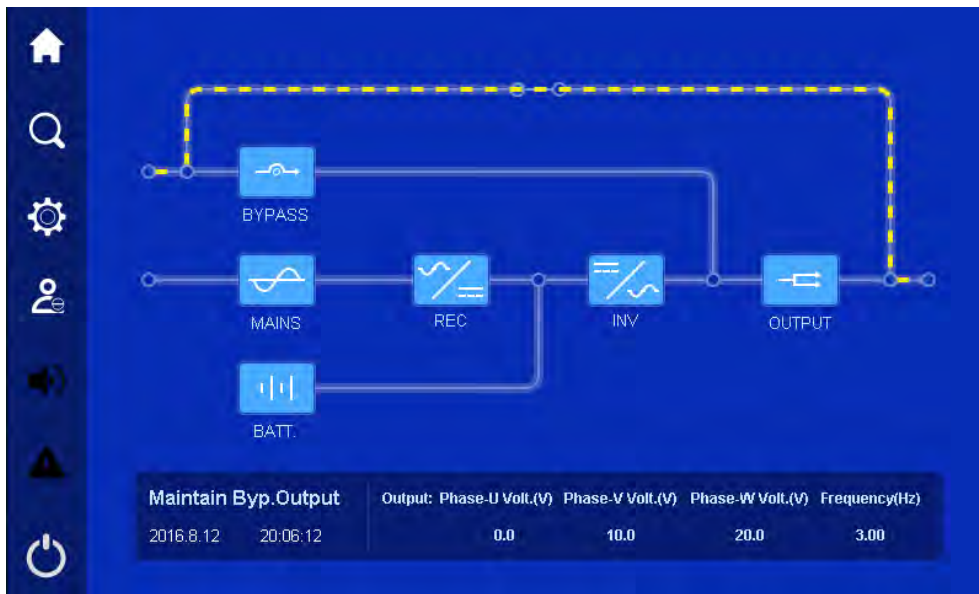

Figure4-13 Maintenance bypass output

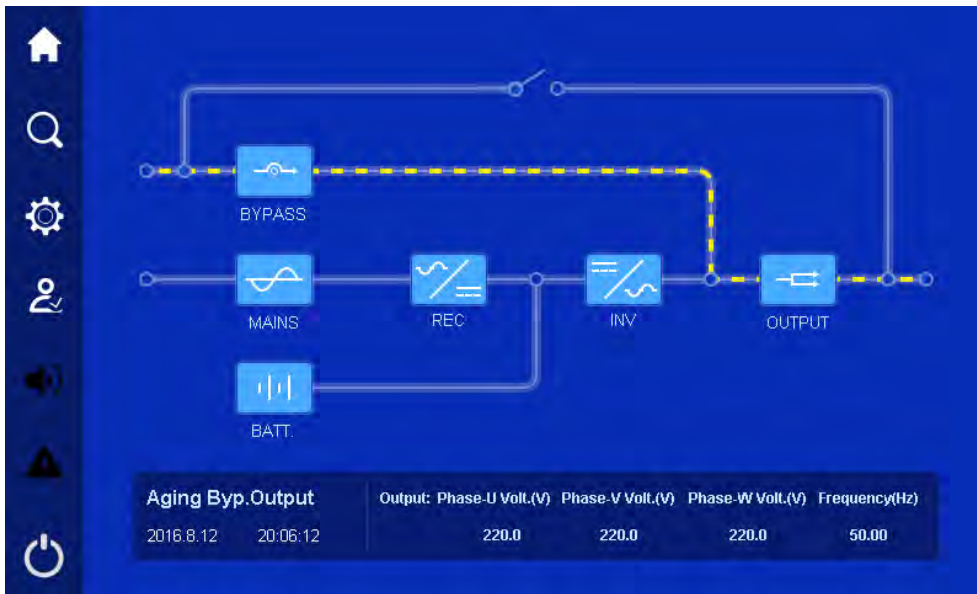

Figure4-14 Aging bypass output

When module or system abnormal, the main page will show “fault alarm” indicator, click the “fault alarm”, it will show the current fault information, as shown in Figure4-15.

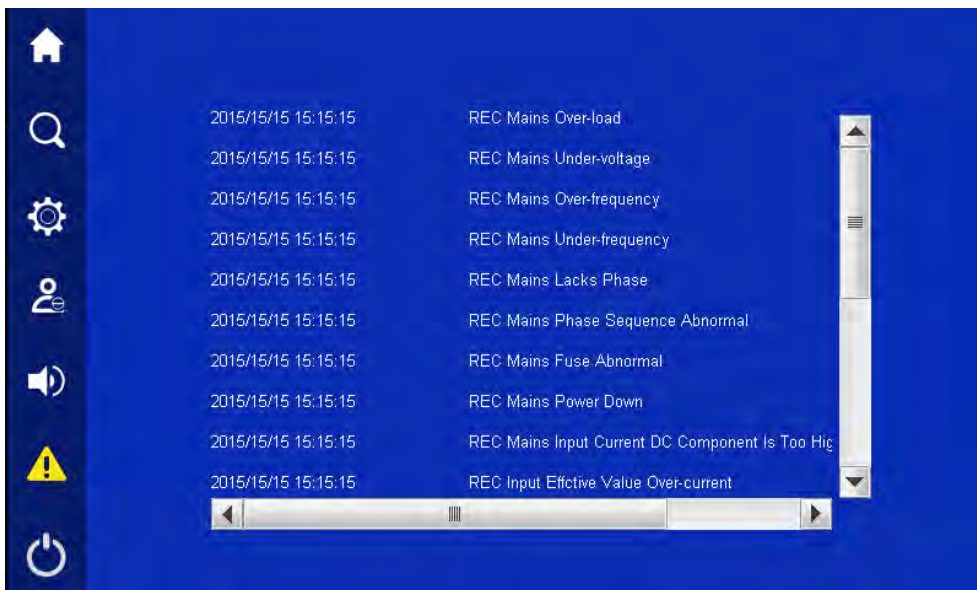



Figure4-15 Current fault information page

4.4 Buzzer Control Function

When module or system abnormal, the system will send sound alarm. User can click the  icon at left to close or open the buzzer. After closed, if there is new fault, the buzzer will be opened automatically.

4.5 Monitor Function

4.5.1 Bypass Information

In main page, click  icon, it will enter system bypass information page, as shown in Figure4-16. In the page, it shows the bypass three-phase voltage, current, active power, apparent power and frequency.

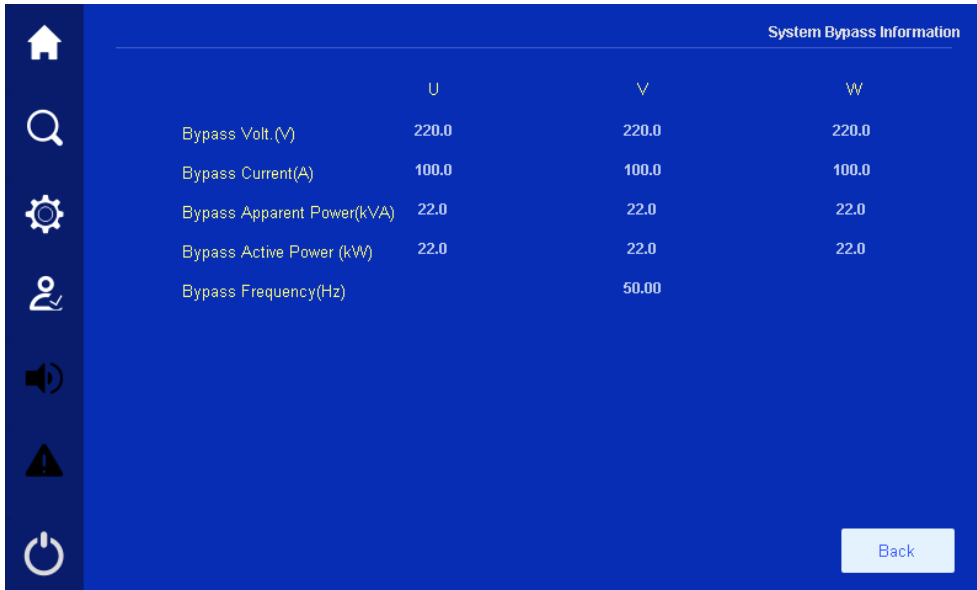

	U	V	W
Bypass Volt.(V)	220.0	220.0	220.0
Bypass Current(A)	100.0	100.0	100.0
Bypass Apparent Power(kVA)	22.0	22.0	22.0
Bypass Active Power (kW)	22.0	22.0	22.0
Bypass Frequency(Hz)		50.00	

Figure4-16 Bypass information

4.5.2 Mains Information

In main page, click  icon, it will enter system mains input information page, as shown in Figure4-17. In the page, it shows the mains three-phase voltage, current, frequency and total input energy of current system.



Mains Information			
	U	V	W
Mains Voltage(V)	220.0	220.0	220.0
Mains Current(A)	100.0	100.0	100.0
Frequency(Hz)		50.00	

Back

Figure4-17 Mains information

4.5.3 Battery Information

In main page, click  icon, it will enter battery information page. If the battery is lead-acid cell, it shows the positive and negative battery group voltage, charge/discharge current, remaining capacity, battery remaining time, battery temperature, battery status. It shows the charging current or discharging current according to battery charge/discharge status, as shown in Figure4-18.

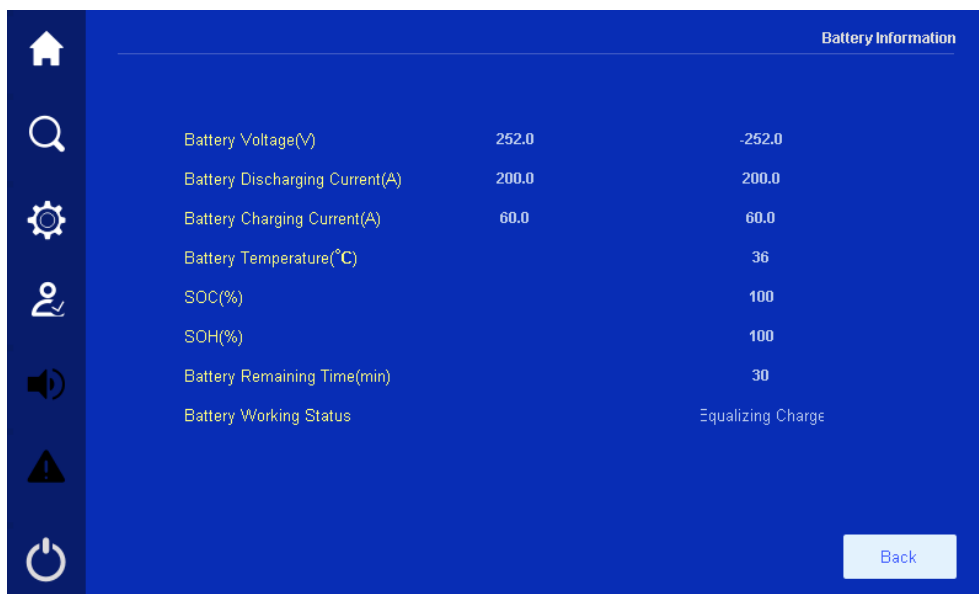

Battery Information		
Battery Voltage(V)	252.0	-252.0
Battery Discharging Current(A)	200.0	200.0
Battery Charging Current(A)	60.0	60.0
Battery Temperature(°C)		36
SOC(%)		100
SOH(%)		100
Battery Remaining Time(min)		30
Battery Working Status		Equalizing Charge

Back

Figure4-18 Battery information

When the battery type is lithium cell, the page shows the positive and negative battery group voltage, charge/discharge current, remaining capacity, battery remaining time, battery temperature, BMS fault

code, SOC, SOH and battery status. It shows the charging current or discharging current according to battery charge/discharge status, as shown in Figure4-19.

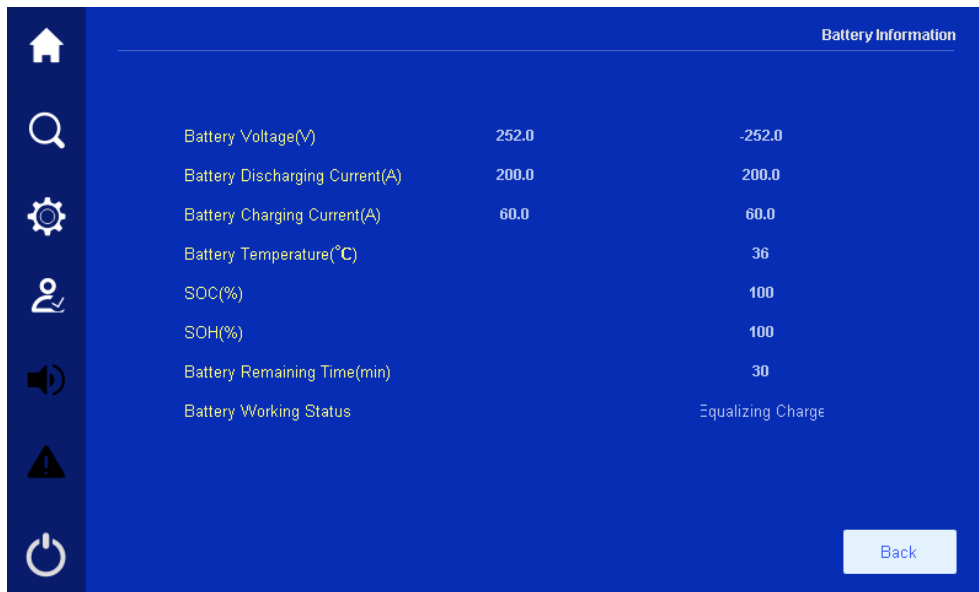



Figure4-19 Battery information page

4.5.4 Power Module Information

In main page, click  icon, it will enter rectifier information page, as shown in Figure4-20. Click “Select Module”, it can check the information of each power module.

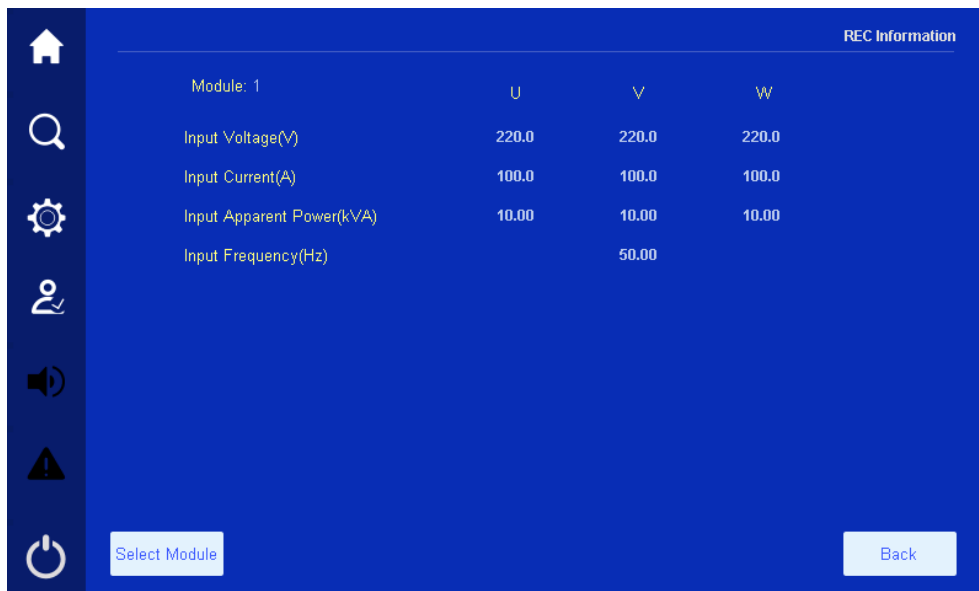



Figure4-20 Rectifier information

4.5.5 Inverter Information

In main page, click  icon, it will enter inverter module information page, as shown in Figure4-21. Click “Select Module”, it can check the information of each power module.

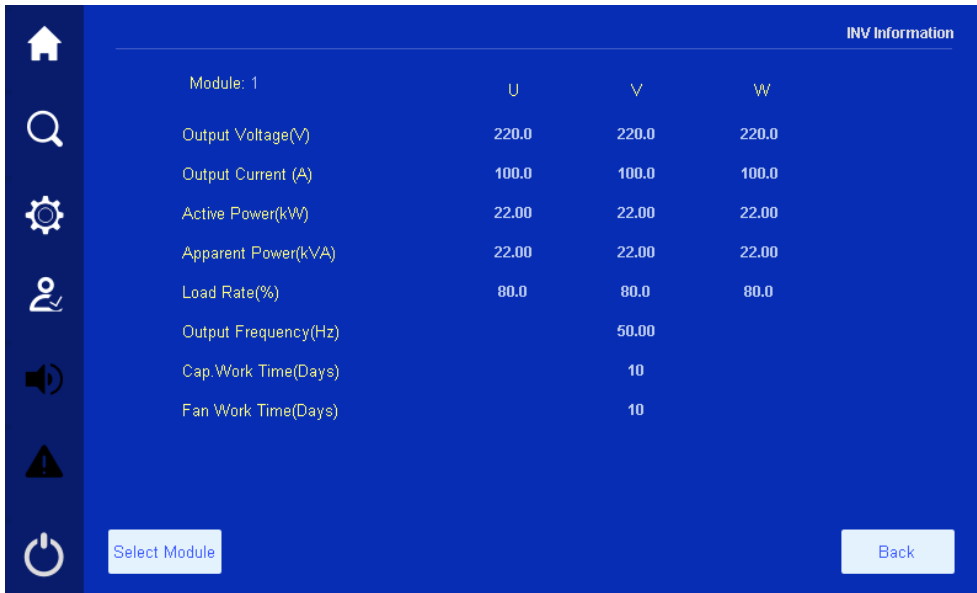



Figure4-21 Inverter module information

4.5.6 Output Information

In main page, click  icon, it will enter system output information page, as shown in Figure4-22. In the page, it shows the current three-phase output voltage, current, active power, apparent power, load percentage, frequency and total output energy.

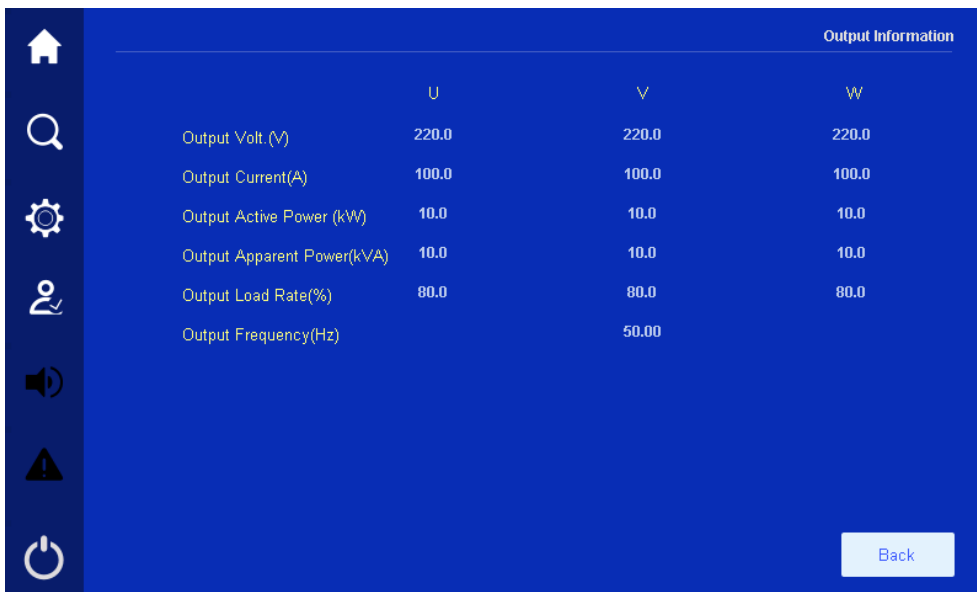



Figure4-22 System output information

4.6 Setting Management

In main page, click  icon, it will enter user login page, as shown in Figure4-23.

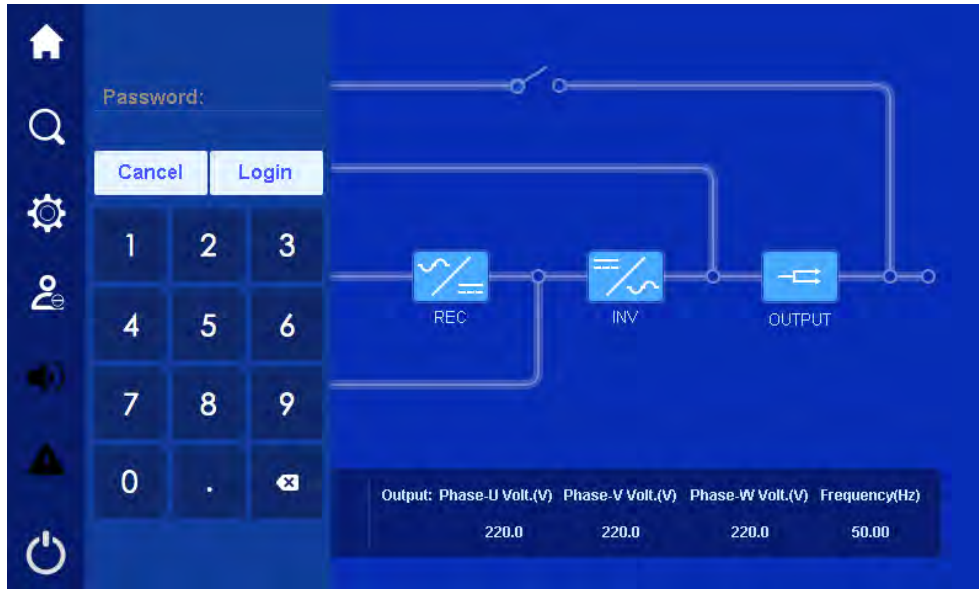



Figure4-23 Use login page

After entering right password the icon will show as . Click the left  icon, it will turn to setting interface, as shown in Figure4-24. Common user can check the parameters, but cannot set the parameters. Maintenance staff can check and set each parameter.

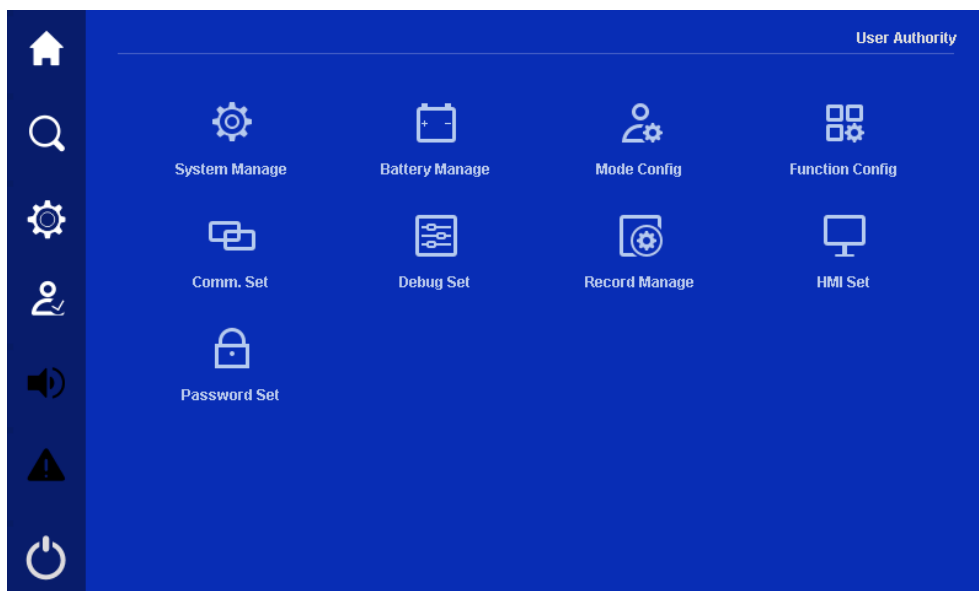

Figure4-24 Setting management page

4.6.1 System Manage

In setting management interface, click **System Manage** icon, it will enter system manage page, as shown in Figure4-25. System manage includes system setting, bypass setting. Click enter box to change parameter. Click **save** button to save the setting.

System setting

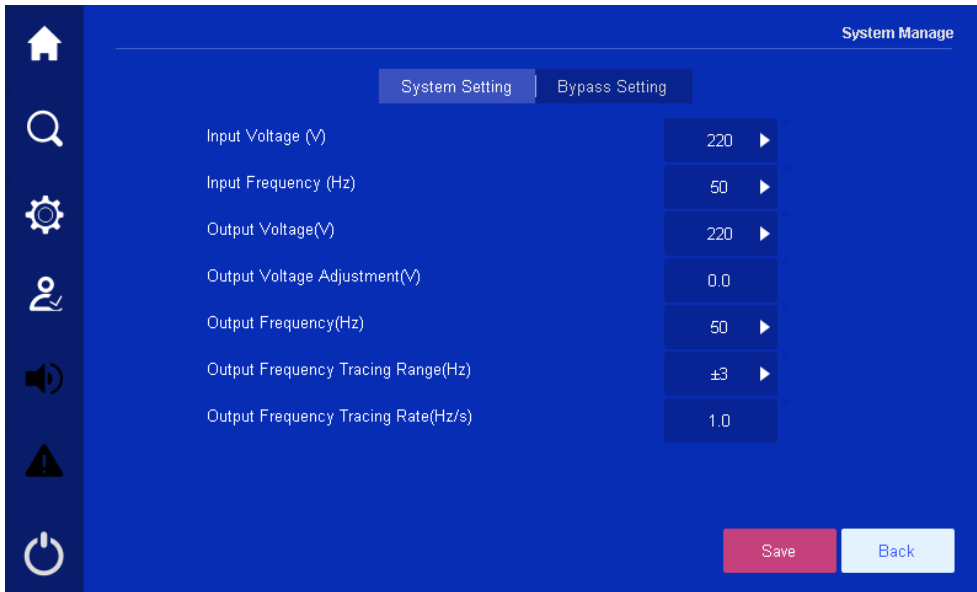



Figure4-25 System setting

If the setting succeeds, on the right of the parameter, it will show  mark, as shown in Figure4-26. If setting fails, it will show  mark, as shown in Figure4-27.

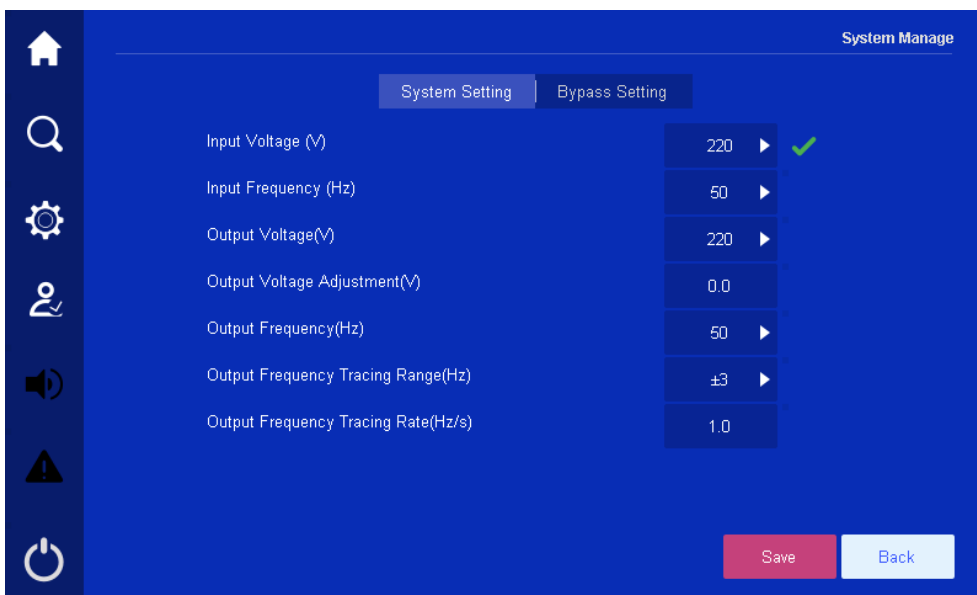

Figure4-26 Setting success

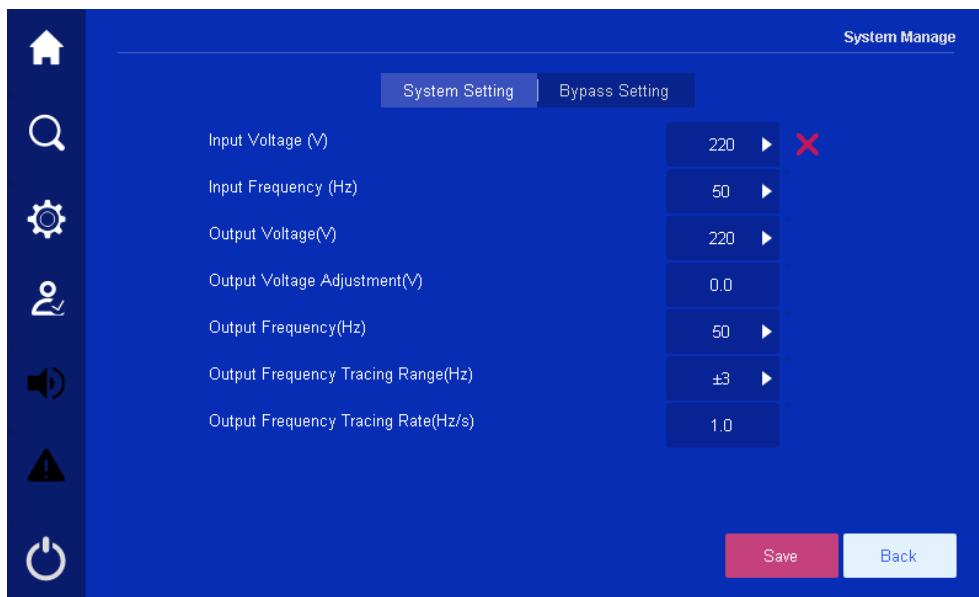

Figure4-27 Setting failure

Bypass setting

Click **Bypass Setting**, it will turn to bypass setting page, as shown in Figure4-28. Click enter box, such as the max. time turn INV. to bypass synchronous (ms), it will show as Figure4-29. At the top of the enter box, it shows the setting range, once setting exceed the range, the setting will be invalid, after change the parameter, click **Save** button to save the setting. The mark of setting success and setting failure is the same as that of system setting.

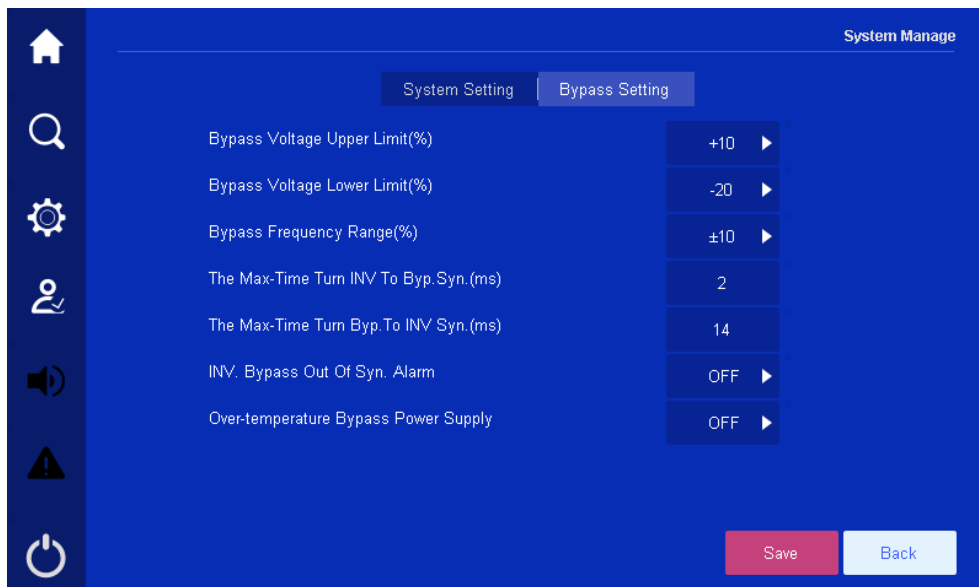

Figure4-28 Bypass setting

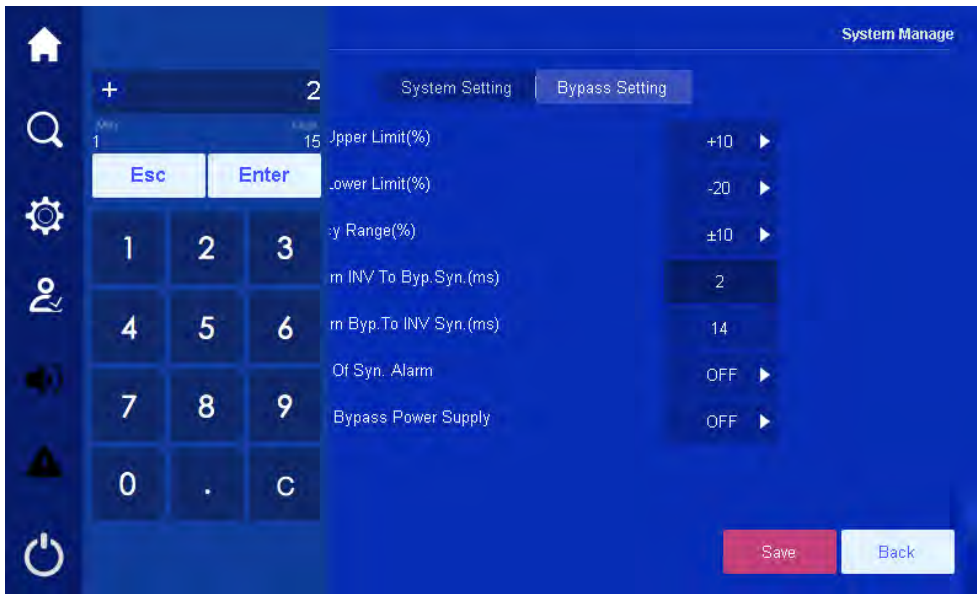

Figure4-29 Parameter setting

4.6.2 Battery Manage

In setting management page, click **Battery Manage** icon, it will enter battery manage page, as shown in Figure4-30, Figure4-31. The page includes battery setting, charging setting, battery test. Click enter box to change the parameter. Click **Save** button to save the setting. The mark of setting success and setting failure is the same as that of system setting.

Battery setting



Figure4-30 Battery setting 1

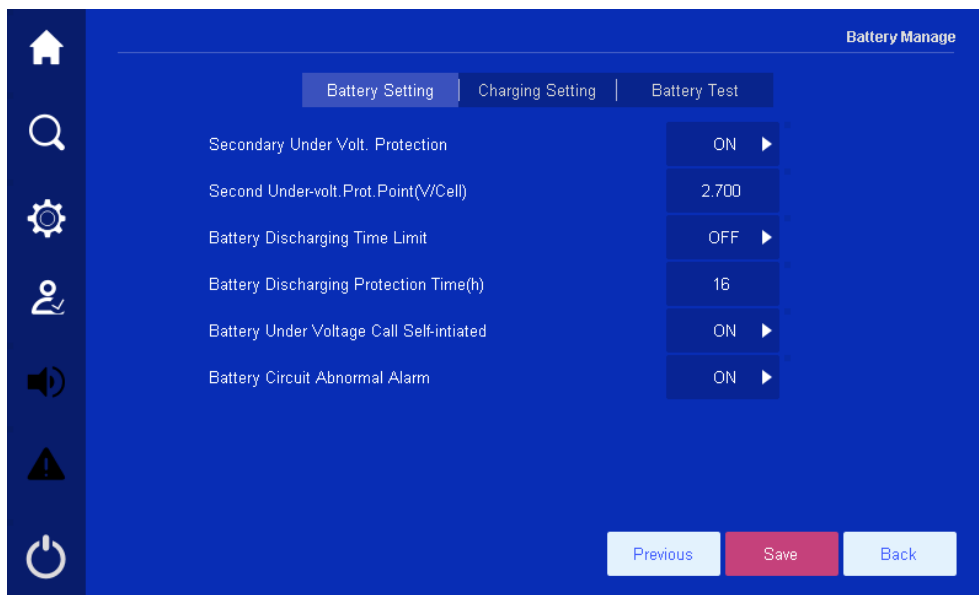

Figure4-31 Battery setting 2

Charging setting

Click **Charging Setting**, it will turn to charging setting page, as shown in Figure4-32, Figure4-33. Click enter box to change the parameter. Click **Save** button to save the setting. The mark of setting success and setting failure is the same as that of system setting.



Figure4-32 Charging setting 1

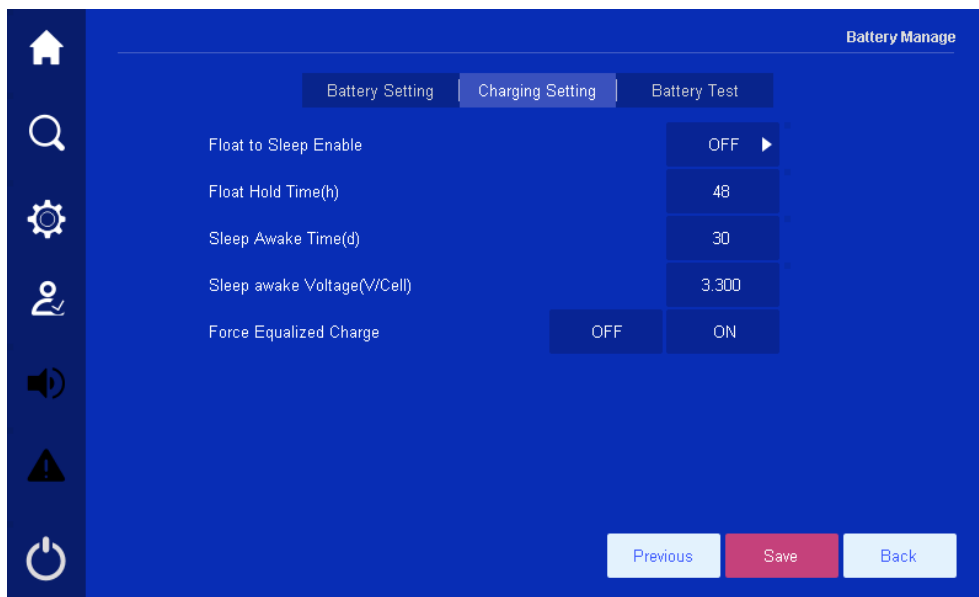

Figure4-33 Charging setting 2

Battery test

Click **Battery Test** to enter battery test page, as shown in Figure4-34.

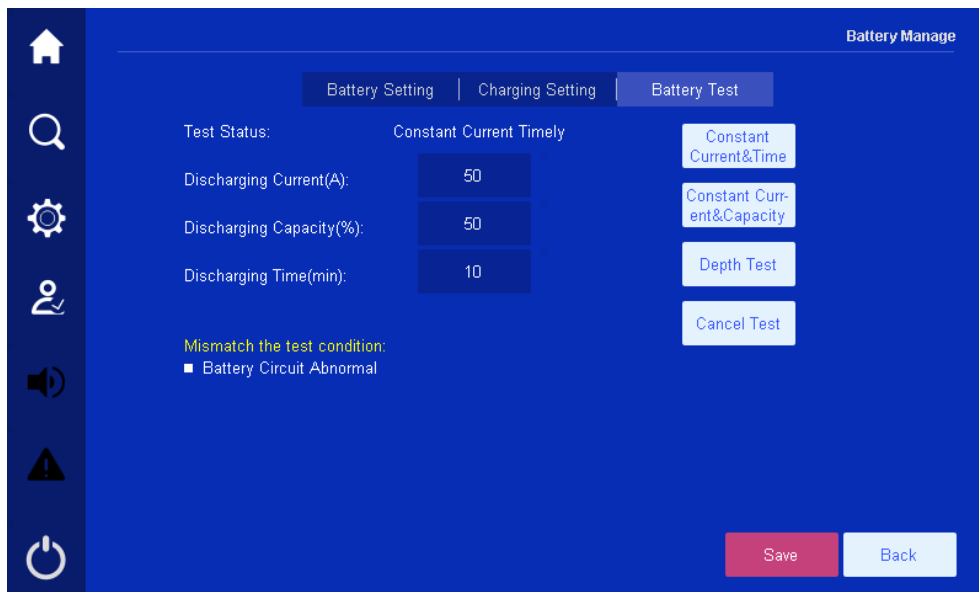

Figure4-34 Battery test

4.6.3 Mode Configuration

In setting management page, click **Mode config.** icon, it will enter mode configuration page. The page includes parallel configuration, ECO configuration, smart sleep setting and other mode setting. After setting, click **Save** button to save the setting. The mark of setting success and setting failure is the same as that of system setting.

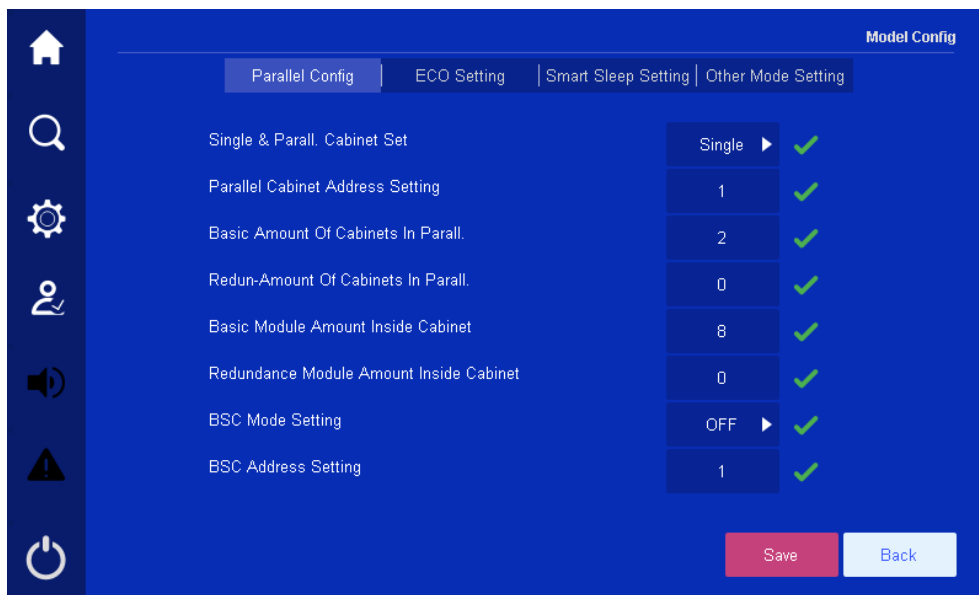

Figure4-35 Parallel configuration page

Click **ECO Setting**, it will turn to ECO configuration page, as shown in Figure4-36. Click enter box to change the setting. Click **Save** button to save the setting. The mark of setting success and setting failure is the same as that of system setting.

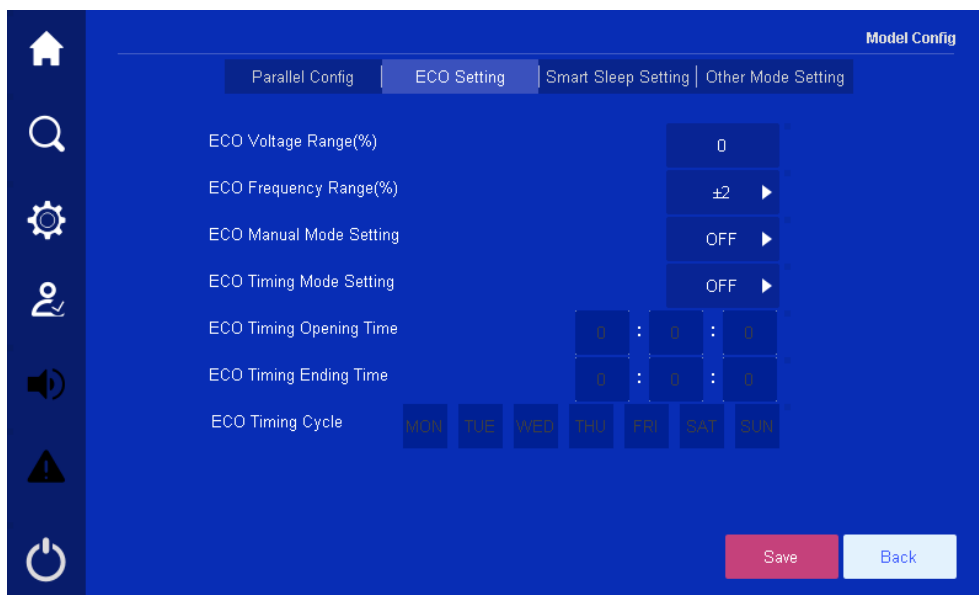

Figure4-36 ECO setting page

Click **Smart Sleep Setting**, it will turn to smart sleep setting page, as shown in Figure4-37. Click ente box to change the setting. Click **Save** button to save the setting. The mark of setting success and setting failure is the same as that of system setting.

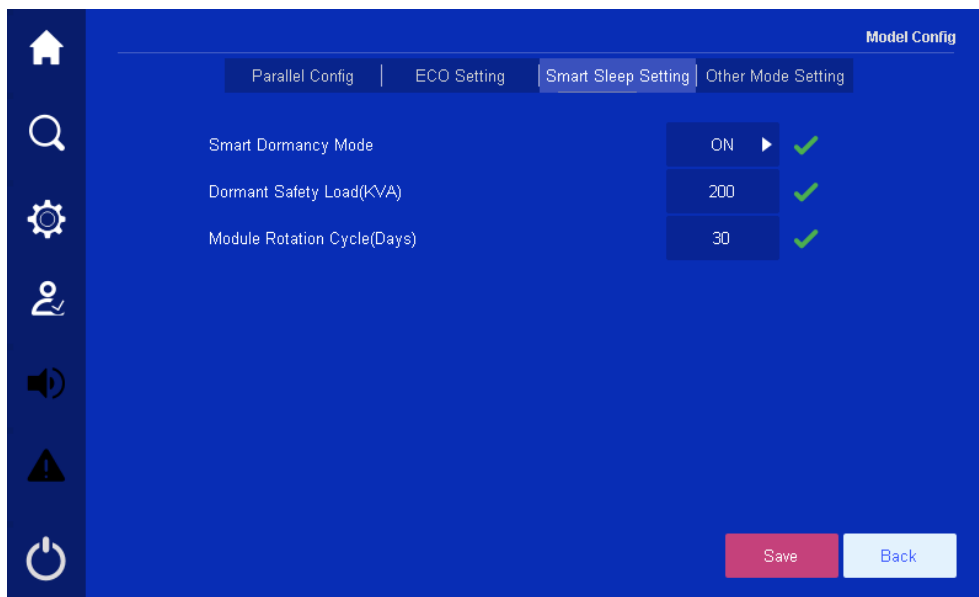

Figure4-37 Smart sleep setting page

Click **Other Mode Setting**, it will turn to other mode setting page, as shown in Figure4-38. Click enter box to change the setting. Click **Save** button to save the setting. The mark of setting success and setting failure is the same as that of system setting.

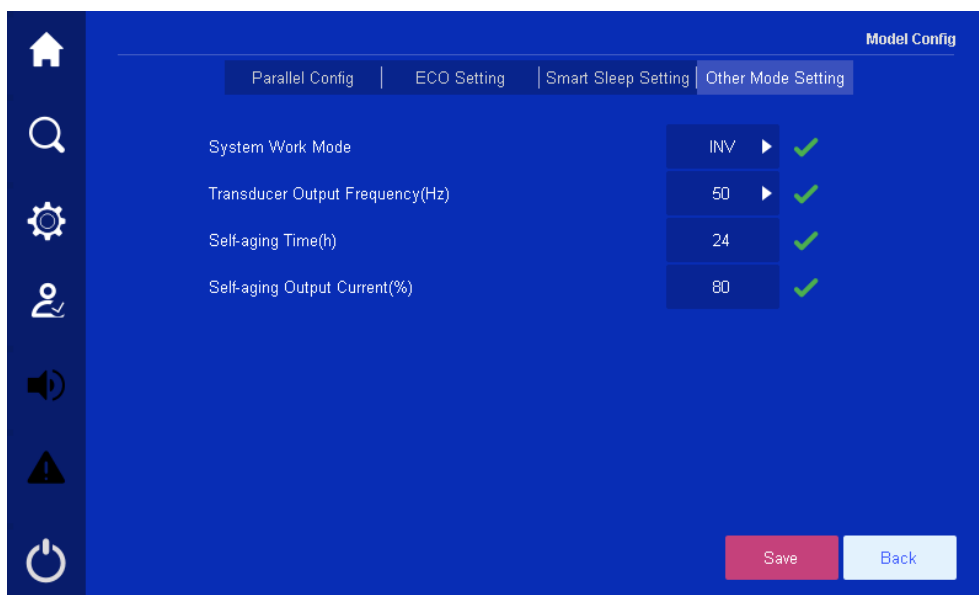

Figure4-38 Other mode setting page

4.6.4 Function Configuration

In setting management page, click **Function Config.** icon, it will enter function configuration page. The page includes generator configuration, dedusting configuration, start delay configuration, dry

point configuration. Click **Save** button to save the setting. The mark of setting success and setting failure is the same as that of system setting.

Generator configuration

In function configuration page, click **Generator**, it will enter the generator configuration page, as shown in Figure4-39. Click **Save** button to save the setting. The mark of setting success and setting failure is the same as that of system setting.

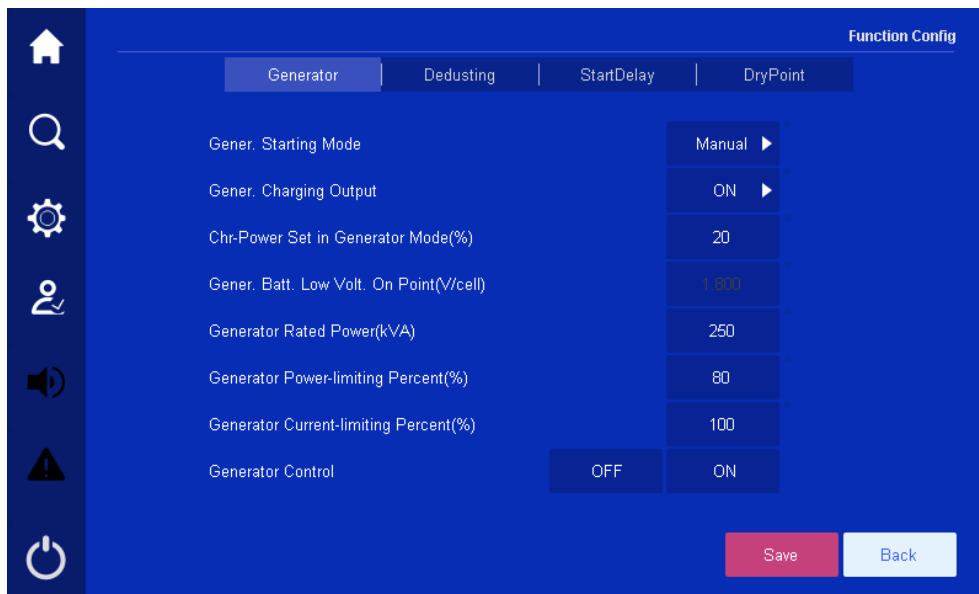

Figure4-39 Generator configuration

Dedusting configuration

Click **Dedusting**, it will enter the dedusting configuration page, as shown in Figure4-40. Click **Save** button to save the setting. The mark of setting success and setting failure is the same as that of system setting.

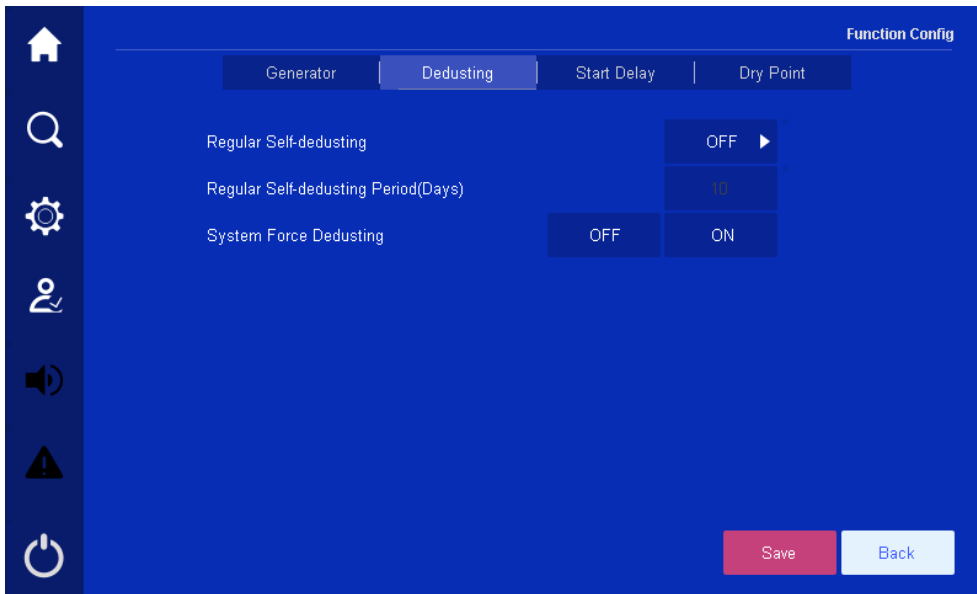

Figure4-40 Dedusting configuration

Start delay configuration

Click **StartDelay**, it will enter the delay starting configuration page, as shown in Figure4-41. Click **Save** button to save the setting. The mark of setting success and setting failure is the same as that of system setting.

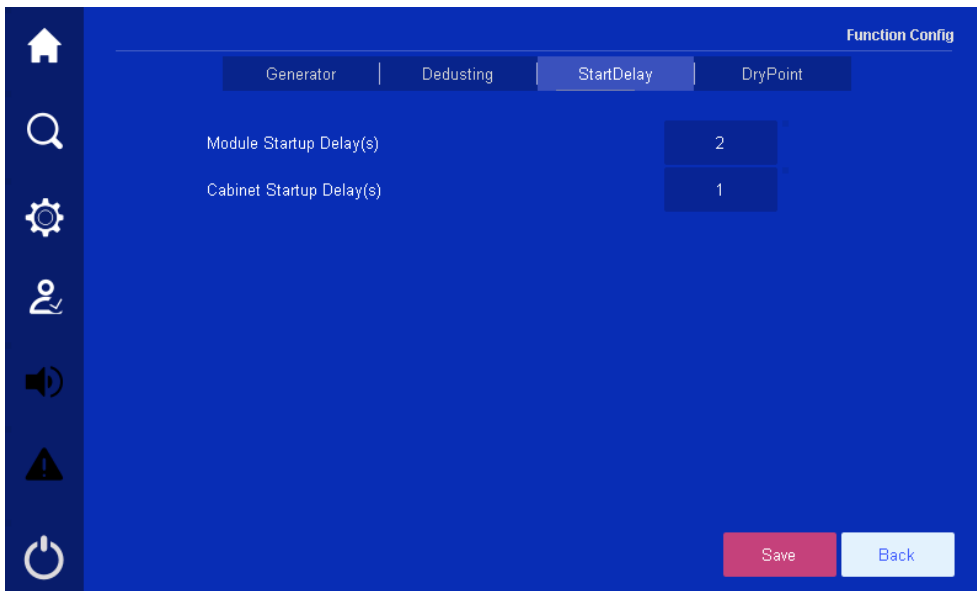

Figure4-41 Delay starting configuration

Dry point configuration

Click **Dry point**, it will enter the dry contact configuration page, as shown in Figure4-42. Click **Save** button to save the setting. The mark of setting success and setting failure is the same as that of system setting.

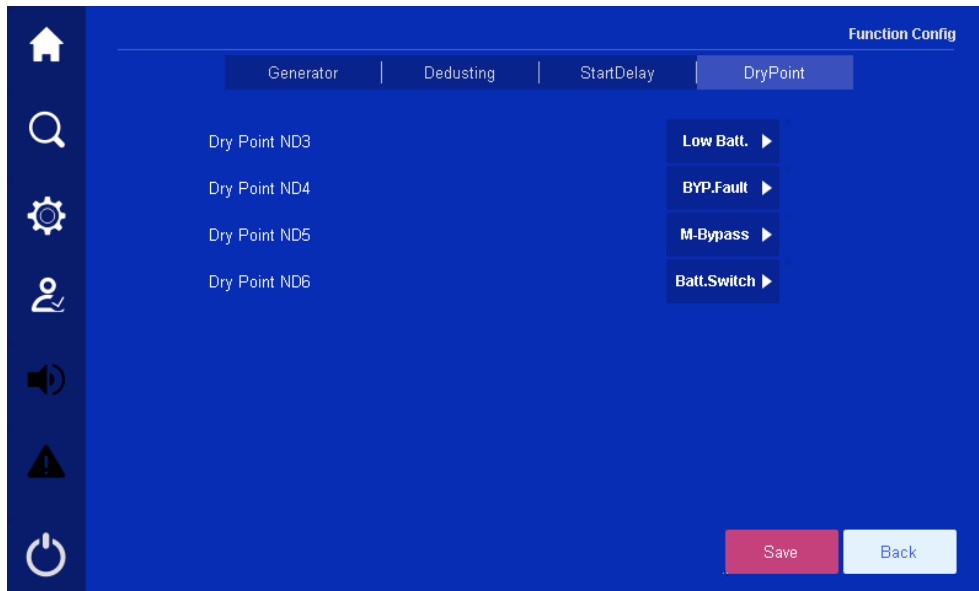

Figure4-42 Dry contact configuration

4.6.5 Communication Setting

In setting management page, click **Communication Setting** icon, it will enter communication setting page, as shown in Figure4-43. Click **Save** button to save the setting. The mark of setting success and setting failure is the same as that of system setting.

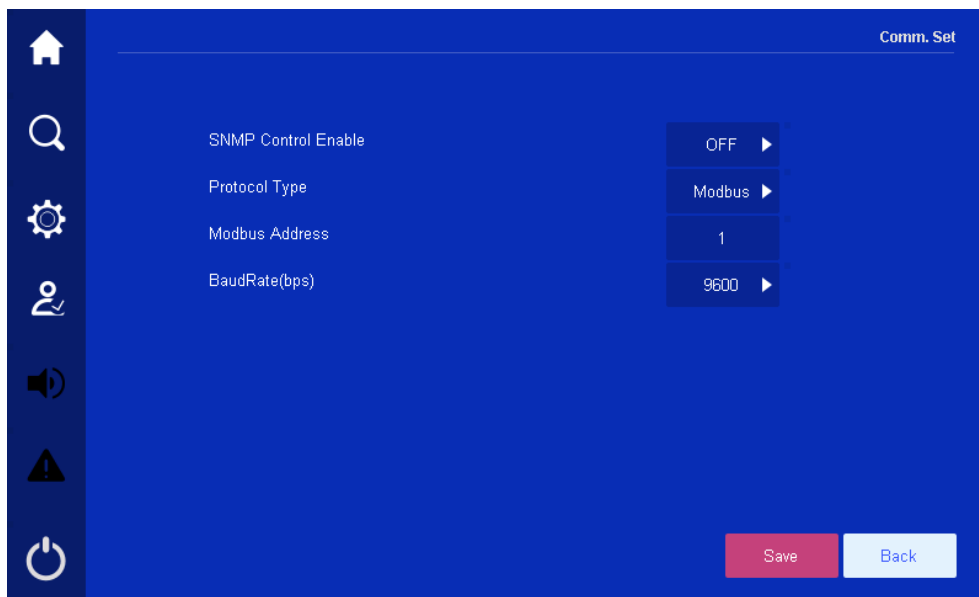

Figure4-43 Communication setting

4.6.6 Debug Set

In setting management page, click **Debug Set** icon, it will enter debug set page, as shown in Figure4-44. Click **Save** button to save the setting. The mark of setting success and setting failure is the same as that of system setting.

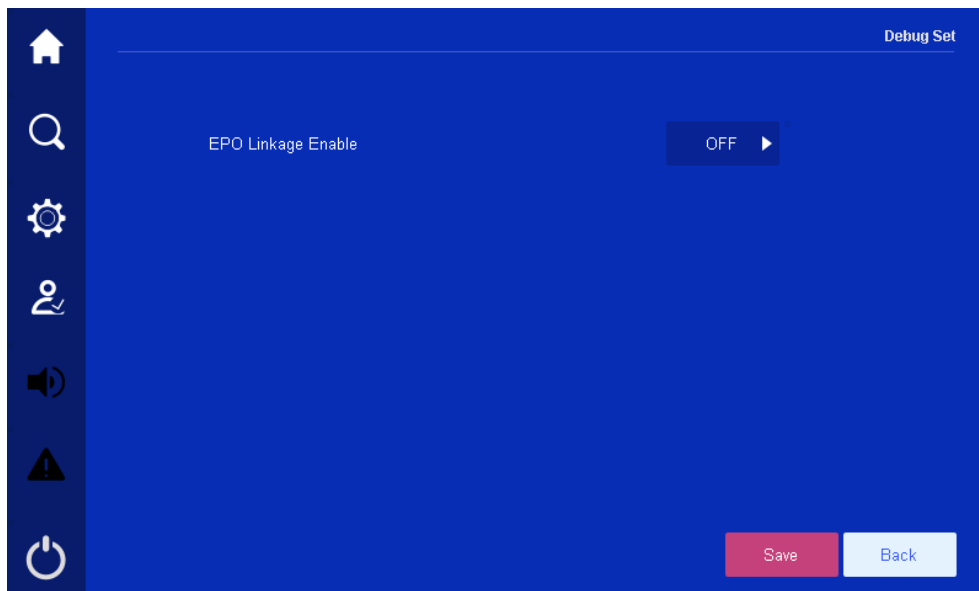

Figure4-44 Debugging setting

4.6.7 Record Manage

In setting management page, click **Record Manage** icon, it will enter record manage page, as shown in Figure4-45, Figure4-46. Click **Save** button to save the setting. The mark of setting success and setting failure is the same as that of system setting.

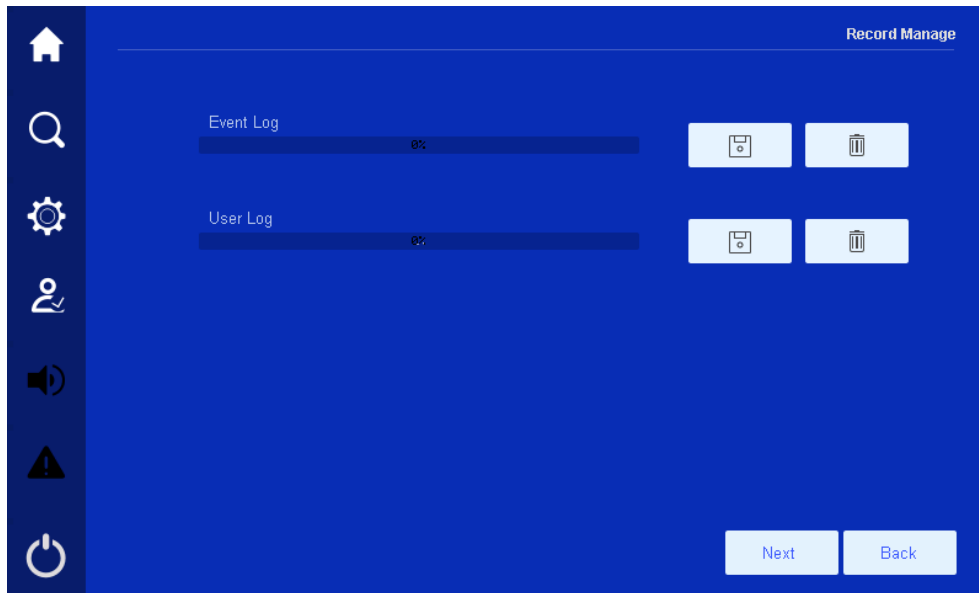

Figure4-45 Record manage 1

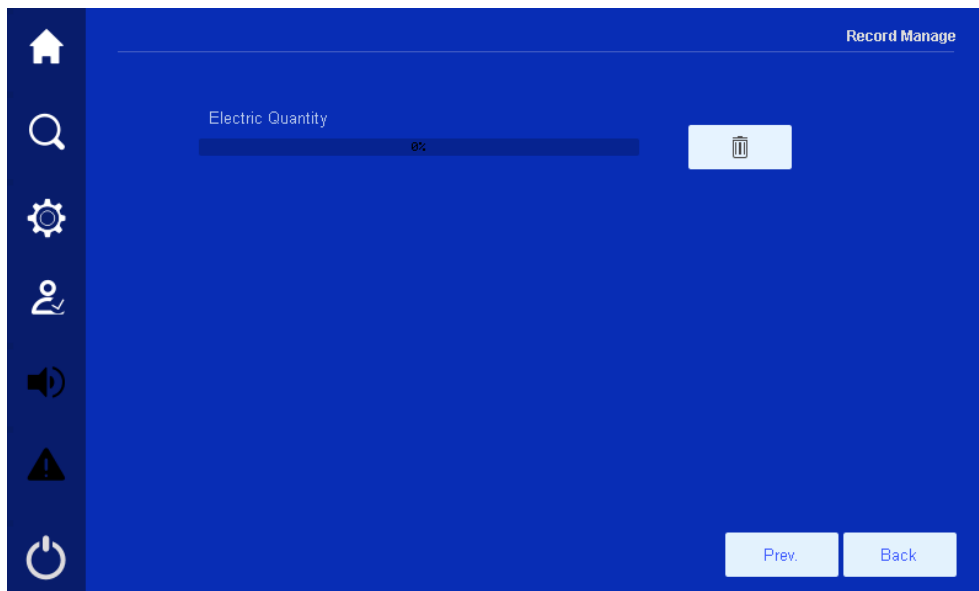

Figure4-46 Record manage 2

4.6.8 HMI Set

In setting management page, click **HMI Set**, it will enter HMI set page, as shown in Figure4-47.

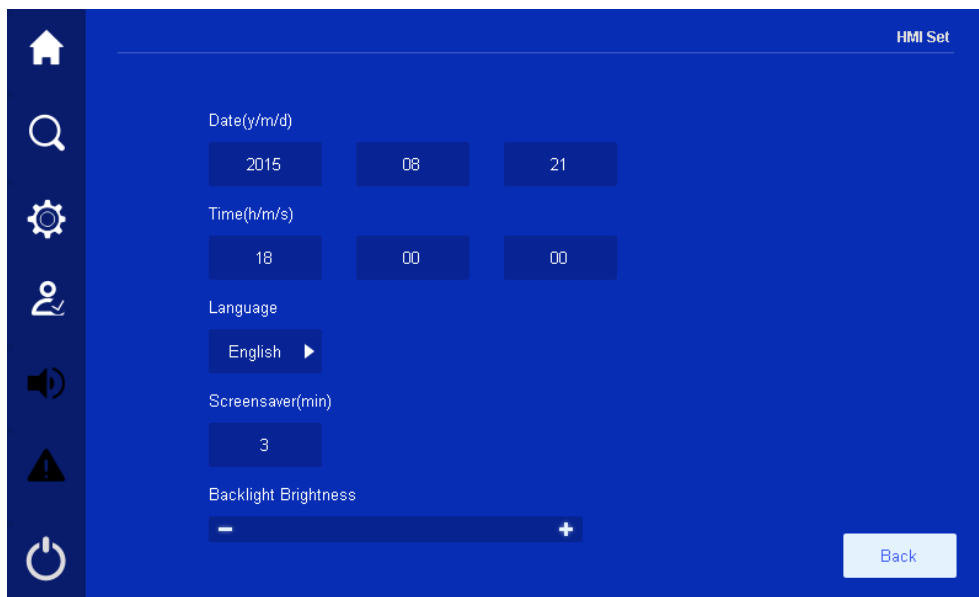

Figure4-47 HMI setting



CAUTION

When setting system time, ensure that the setting value is the same as the real time, which is to keep the veracity of system event log and master the system status of some time and maintain conveniently.

4.6.9 Password Set

In setting management page, click **Password Set** icon, it will enter password set page. In password setting page, user can only change the password of current user, as shown in Figure4-48. The password is 1 to 6 places Arabic numerals. After filling, click **Save** button to change the setting.

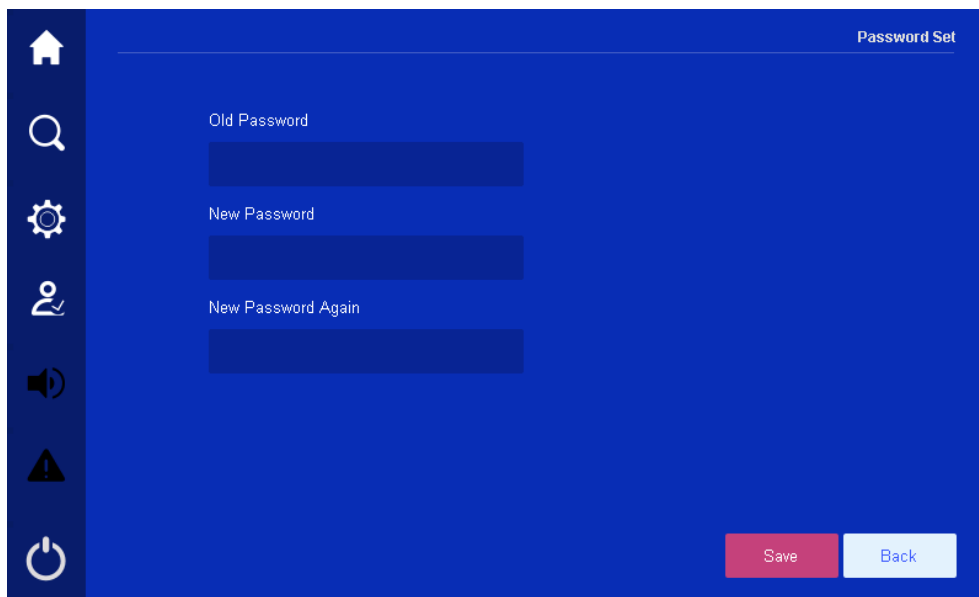



Figure4-48 Password setting

4.7 Information Query

In main page, click  icon, it will enter information query page, as shown in Figure4-49.

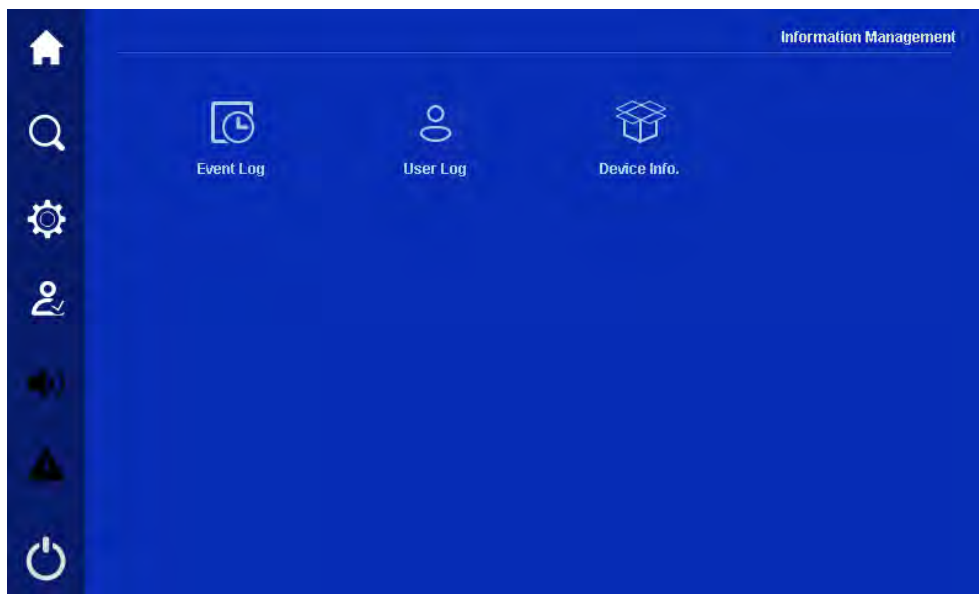

Figure4-49 Information query



CAUTION

It can record 9000 pieces information at most. When the record exceeds 9000 piece, the earliest information will be covered by new one. All records are ranked in inverted order of time.

4.7.1 Event log

In information query page, click **Event log** icon, it will enter event log page, as shown in Figure4-50. This page records the history fault and alarm information of system and module.

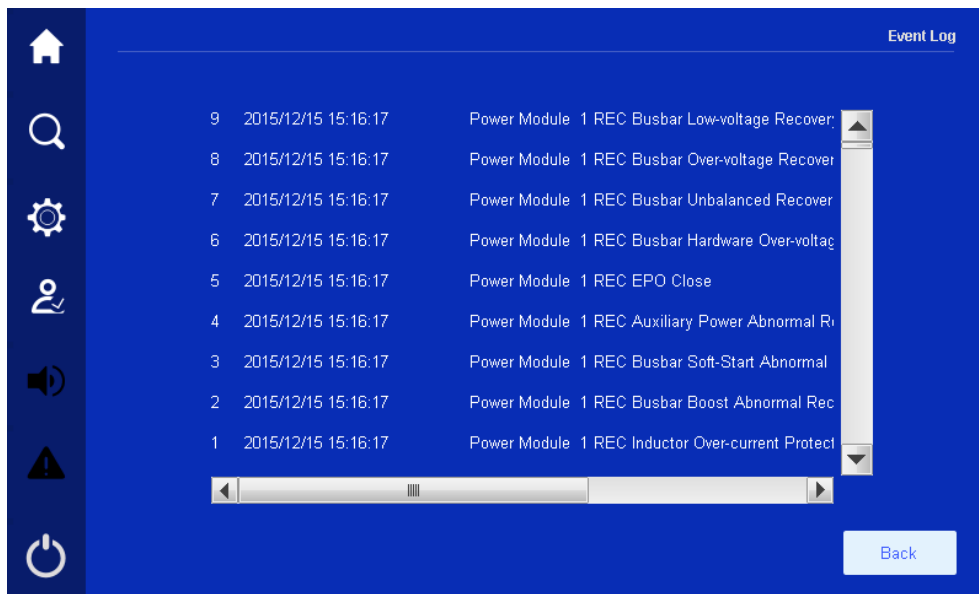

Figure4-50 Event log

4.7.2 User Log

In information query page, click **User Log** icon, it will enter user log page, as shown in Figure4-51. This page shows the user parameter setting record.

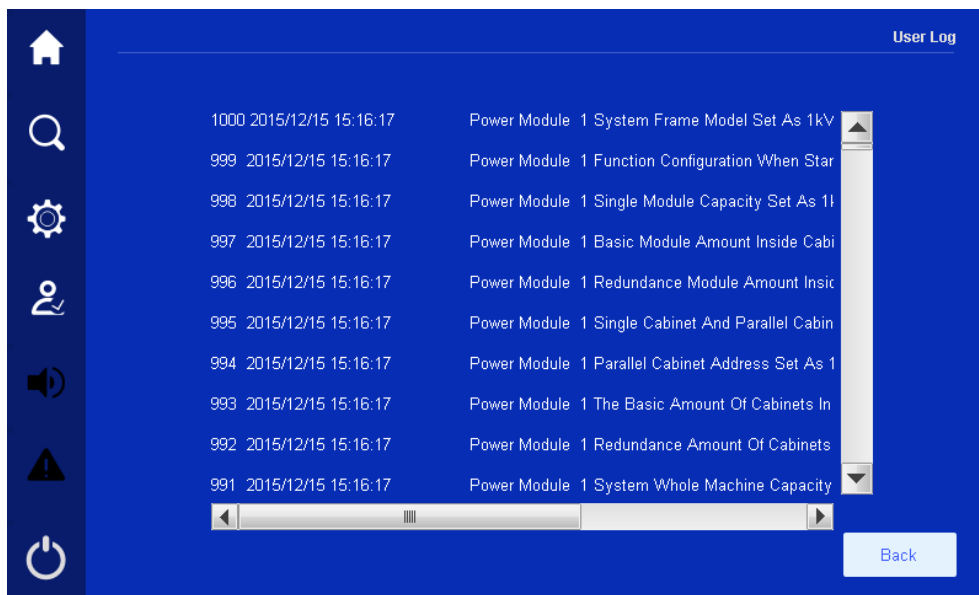

Figure4-51 User log

4.7.3 Device Information

In information query page, click **Device Info** icon, it will enter device information page. This page shows the S/N, product name, model, status, version, as shown in Figure4-52, Figure4-53, Figure4-54.

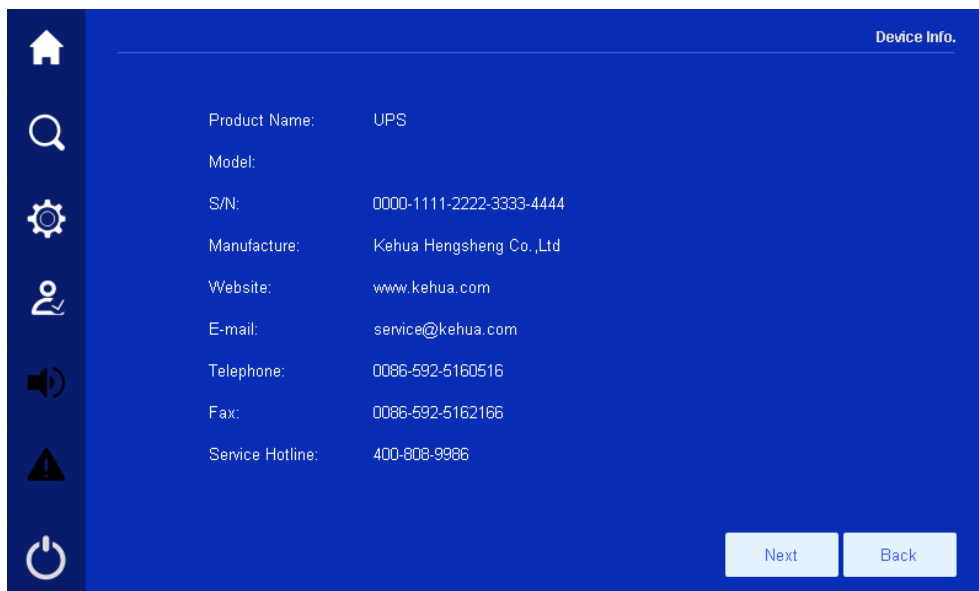

Figure4-52 Product information 1

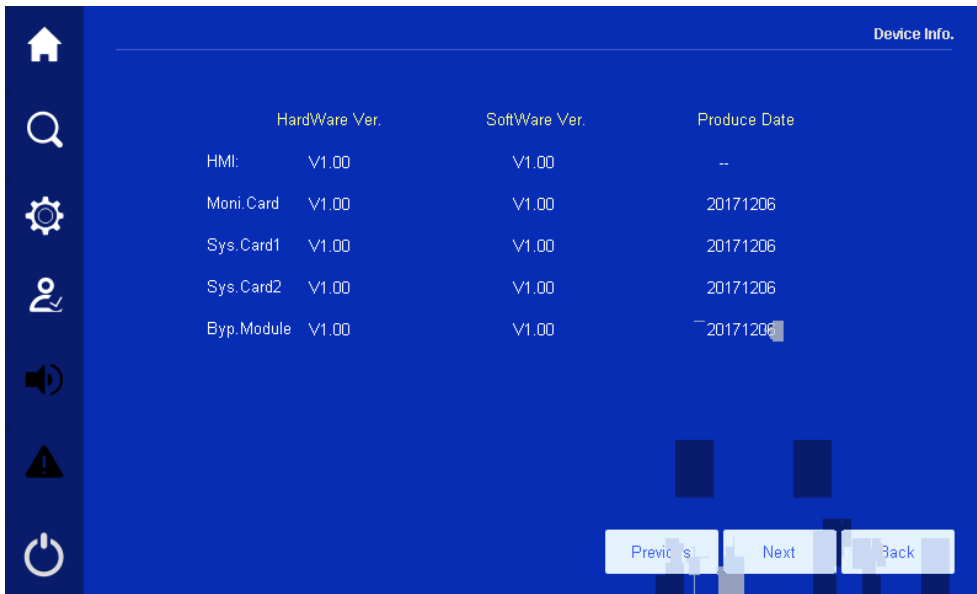

Figure4-53 Product information 2

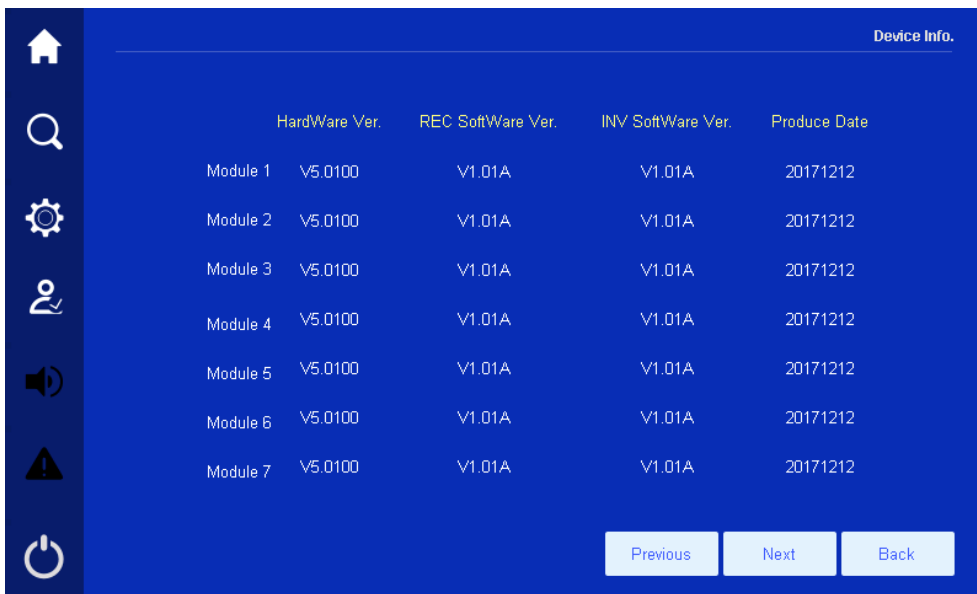

Figure4-54 Product information 3

When the probation function is enabled, the device status shows as **Lock**, as shown in Figure4-55. At this time, click **Lock** button, it will enter the probation unlock page. After unlocking, the **Lock** button disappear.

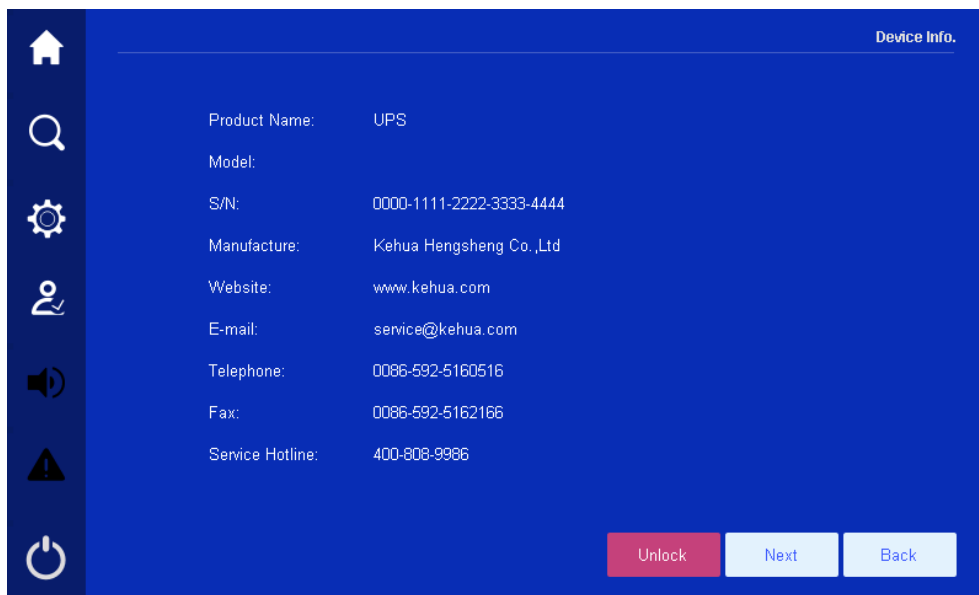



Figure4-55 Probation function is enabled

4.8 ON/OFF

In main page, click  icon, it will enter ON/OFF page, when the system is OFF, click the icon to enter the confirm page, as shown in Figure4-56, click **OK** button to perform the start operation.

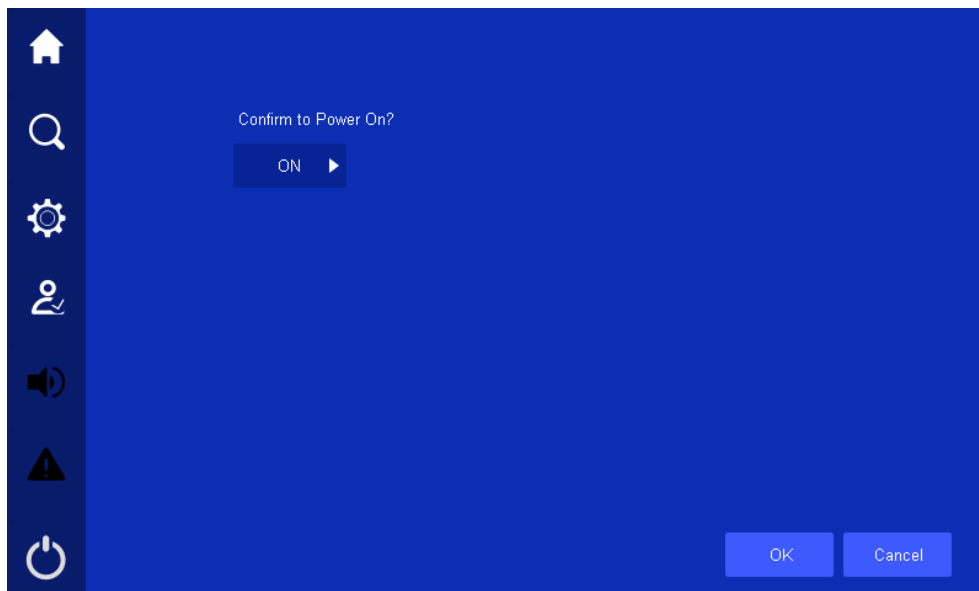



Figure4-56 Confirm to power on

While powering off, click  icon, it will enter the confirm page, as shown in Figure4-57, click **OK** button to perform the shutdown operation.

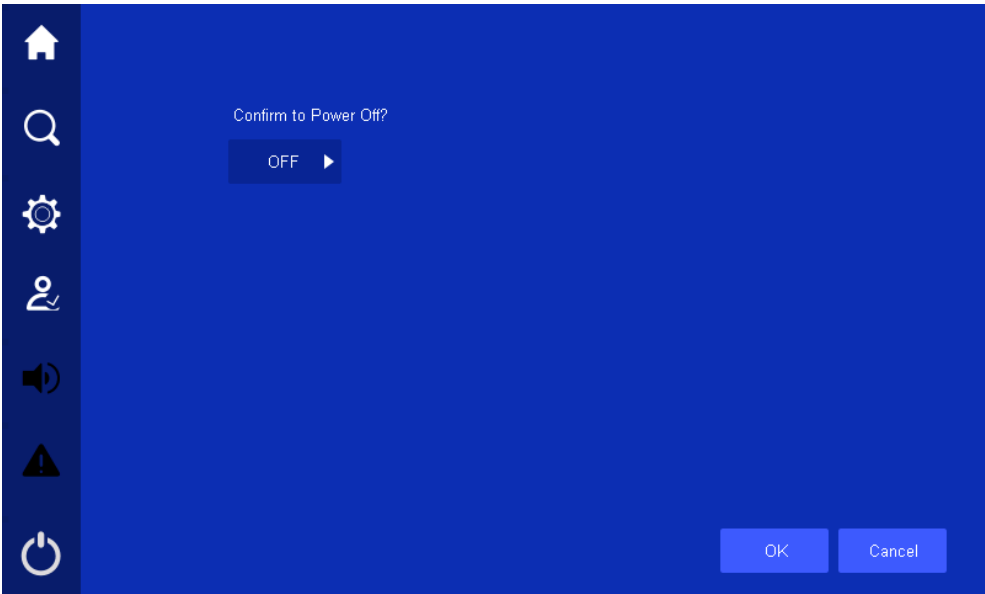

Figure4-57 Confirm to power off

5 Use and Operation

This chapter mainly introduces the operation procedure and method, including using announcements, operation procedure, UPS start and parallel system start, etc.

5.1 Use Announcements

- Before starting the UPS, check whether the load is proper. The load must not exceed the rated output power of the UPS, which is to avoid overload protection.
- Do not use the <ON> and <OFF> buttons on the UPS panel as the power supply switches of load. Do not start the UPS frequently.
- After UPS work stably, turn on the load. Start big-power devices before small-power ones. Some devices have large starting current which may cause overload protection, it is better to start this equipment before others. If the UPS needs to be shut down, turn off the load first.
- When mains power outage, if the UPS is power supplied by generator, it is necessary to start the generator firstly. After the generator work stably, the UPS can be connected, or it may cause UPS or load damage. If the generator needs to be shut down, turn of the UPS firstly.

5.2 Operation Procedure

Before first start the UPS, it is necessary to do the check, see section 5.3.1 .Only pass the examination, then the UPS can be powered on. If the UPS won't be used for a long time, it also needs to be checked before startup. Operation procedure is as shown in Figure5-1.

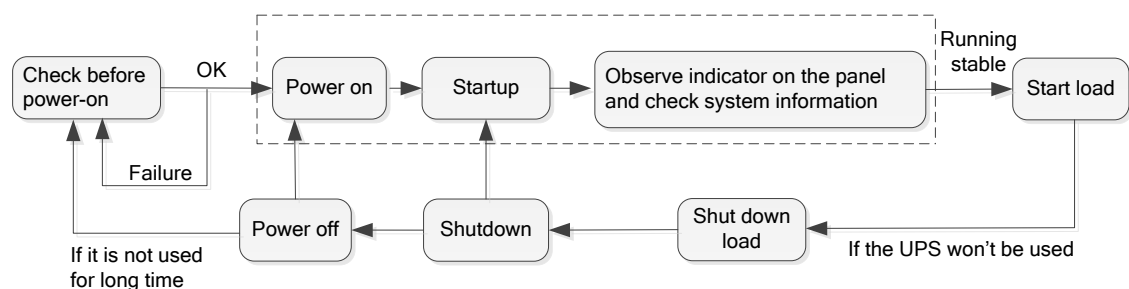

Figure5-1 Operation procedure

5.3 UPS Start and Shutdown

5.3.1 Check before Startup

Before startup, check according to following steps. Only when the check is OK, then the UPS can be started.

- Step 1 Ensure that the POWER switch, BYPASS switch, OUTPUT switch, MAINTENANCE switch are all OFF.
- Step 2 Check load.
- Ensure that the load is not conductive load. The output of the UPS cannot be conductive load, such as motor, fan, air-condition, etc. Generally, these loads are power supplied by power-grid.
 - Ensure that the load is close. And at the same time, the load capacity should not exceed the UPS rated output capacity, or, it will cause overload protection.
- Step 3 Ensure that there is no short-circuit between the live wire and neutral wire, live wire and grounding wire of input and output.
- Step 4 Measure the AC voltage of mains input terminal, and the voltage should be in the range of 80V~280V, or, it only can be started from battery status.
- Step 5 Measure the DC voltage of battery input terminal. The voltage of positive battery group should be greater than a certain value ($+11.5 \times$ battery amount), the voltage of negative battery group should be less than a certain value ($-11.5 \times$ battery amount), and pay attention to the polarity, avoid wrong battery connection.
- Step 6 Ensure that the auxiliary contact of battery breaker is connected to the ND6 dry contact of system monitor card.

----End

5.3.2 Startup

- Step 1 Ensure that all the system parameters setting are right.
- Step 2 Close the ready switch of bypass module and all power modules.
- Step 3 Close the BYPASS switch → POWER switch → external battery switch, the UPS outputs by bypass. (if it is battery start, for this step, just close the external battery switch, and then press the battery button on the bypass module for more than 3s, the system power is set up.)
- Step 4 Start the inverter.

- Start the inverter by panel ON combination button 1

When the green indicator of all power module slow flicker, long press the panel “ON” combination button for 3s, the system inverts to output. Check the system running status in the touch screen, and ensure that the system turns to inverter power supply mode. During testing, ensure that the UPS three-phase output voltage and frequency is normal through the real-time data in the touch screen.

- Start the inverter by touch screen 2

In main page of touch screen, click  icon, it will enter the ON/OFF page, as shown in Figure5-2, click **OK** to perform the start operation.

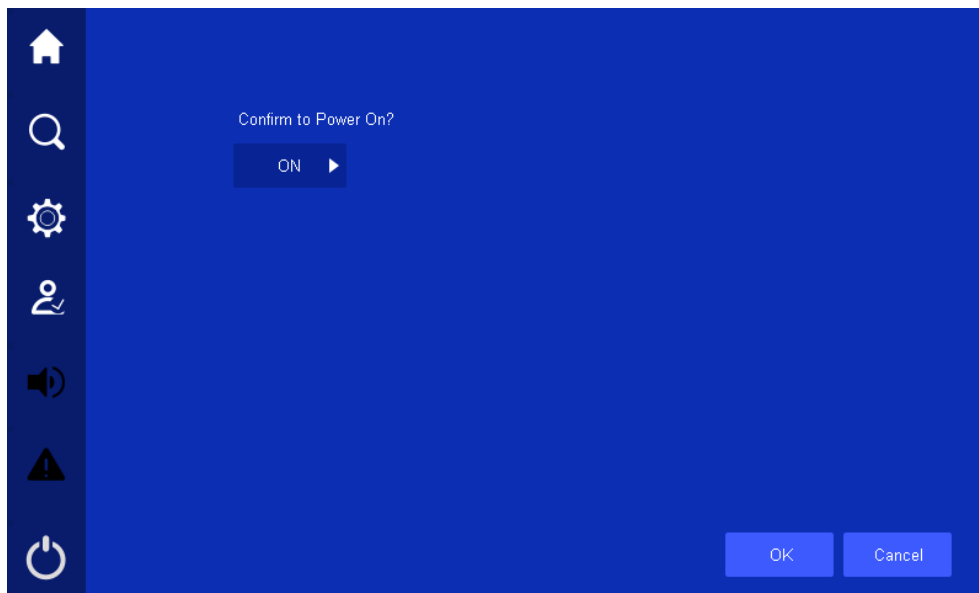

Figure5-2 ON/OFF page

- Step 5 After start the inverter, UPS turns to inverter to supply power. User can check the system running status chart and ensure if the system turns to inverter supply power. During testing, ensure that the UPS three-phase output voltage and frequency is normal through the real-time data in the touch screen.
- Step 6 Close the OUTPUT switch, measure the output voltage, output frequency by multimeter, and ensure the voltage and frequency normal, and then, the UPS can be put into use.
- Step 7 Start the load. Generally, start the large-power device first, and then start the small-power device.

----End

5.3.3 UPS Shutdown



CAUTION

If the system bypass normal, after the UPS shutdown, system will turn to bypass power supply mode; if system bypass abnormal, after the UPS shutdown, system will be with no output. Before shutting down, please ensure that the load is closed.

Step 1 Shut down the user load.

Step 2 Shut down the inverter.

- Shut down the inverter by panel OFF combination button 1

Long press the panel OFF combination button for 3s, system will turn to bypass supply power from inverter output. Check the system running status on the touch screen, and ensure that the system has turned to bypass output from inverter to supply power.

- Shut down the inverter by touch screen 2



In main page, click  icon, it will enter ON/OFF page, as shown in Figure5-3, click **OK** button to perform the shutdown operation..

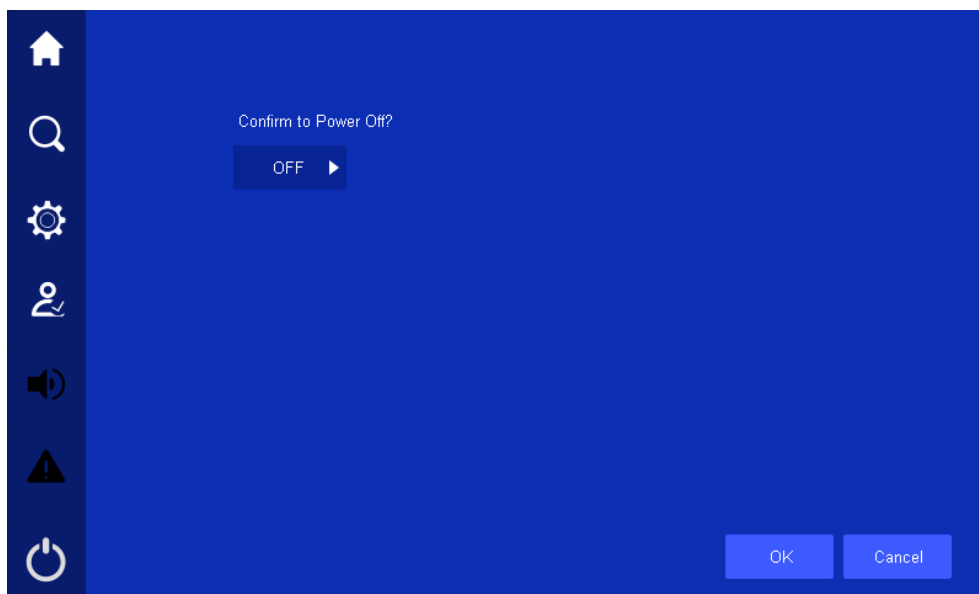

Figure5-3 ON/OFF page

Step 3 Disconnect the external battery switch → POWER switch → BYPASS switch → OUTPUT switch.

Step 4 After the touch screen and all LED indicators are off, the UPS is completely shut down.

----End

5.3.4 Switch to Bypass Mode Manually



CAUTION

Before shutting down the inverter, please ensure that the bypass is normal. If bypass abnormal, after shutting down the inverter manually, the system will be with no output and the power supply for load will be broken off.

Shut down the UPS inverter, please see step 2 in 5.3.3 *UPS Shutdown*, The system will turn to bypass to supply power automatically.



NOTE

When the bypass input voltage or frequency exceeds the setting value, shutting down the inverter will cause system without output, and the power supply for load will be interrupted.

5.3.5 Switch to Maintenance Bypass Mode From Normal Output



CAUTION

Unless professional person, no one can perform the following operation. Manufacturer does not take charge of the problem caused by the operation of untrained person.

Step 1 Shut down the inverter. In main page, click  icon, it will enter ON/OFF interface, click **OFF** and then click **OK** icon to shut down the inverter.



NOTE

The inverter also can be shut down by OFF combination button on the panel, generally, it is not suggested to operate like this.

Step 2 After switch to bypass and the energy flow on the touch screen shows bypass output, place the MAINTENANCE switch to ON position.

Step 3 Disconnect the POWER switch → external battery breaker → BYPASS switch.

- Step 4 Disconnect OUTPUT switch, after the touch screen, LED indicators are all off, the maintenance can be done.

**CAUTION**

During maintenance, it is strictly forbidden to close the OUTPUT switch.

----End

5.3.6 Switch to Inverter Power Supply from Maintenance Bypass

**CAUTION**

Before perform the operation of switching to inverter power supply from maintenance bypass, please ensure that the system bypass input is normal.

- Step 1 Close the BYPASS switch → POWER switch → external battery breaker → OUTPUT switch successively.
- Step 2 After the power supply normal and the energy flow on touch screen shows bypass output, place the MAINTENANCE switch to OFF. At this time, the bypass supply power for load.
- Step 3 Start the inverter system.

When the green indicator of all power module slow flicker, click  icon in main page to enter ON/OFF page, click **ON** and then click **OK** icon to start the inverter. The UPS turns to inverter output.

 **NOTE**

The inverter also can be started by ON combination button on the panel, generally, it is not suggested to operate like this.

----End

5.3.7 Emergency Power Off (EPO)



CAUTION

Do not perform the EPO operation unless emergency.

Press the EPO button on the panel or external EPO button of system, the UPS will turn to emergency power off status. At this time, the touch screen shows EPO protection, and the buzzer long beeps.



CAUTION

- After pressing the EPO button, the UPS will be with no output, the power supply for load is interrupted.
 - When the system stay in maintenance bypass status, after pressing EPO button, the UPS still has output.
-

5.3.8 Emergency Power Off Recovery

- Step 1 Ensure that the dry contact of monitor card, which connected to the external EPO switch, is not in emergency power off status.
- Step 2 Disconnect the POWER switch, OUTPUT switch and battery breaker of battery cabinet, and wait for all system indicators off, the UPS is completely power down.
- Step 3 Close the POWER switch, BYPASS switch, battery breaker of battery cabinet, system will be started again, and EPO removes.

----End

5.4 Parallel System Startup and Shutdown

5.4.1 Start Parallel System

**CAUTION**

1. Before start the parallel system, please perform the operation of 5.3 UPS Start and Shutdown for each UPS.
 2. Before test and power on the parallel system, please ensure that the wire connection of input and output cables and phase sequence is right and the parallel wire is well connected and stay in disconnection status.
 3. Before completely starting the parallel system, please do not start load, and ensure that all switches of load are off.
 4. Before performing the parallel wire operation, please do not connect the parallel wire.
-

- Step 1 Measure the front-end voltage and frequency of all UPS input breaker (including POWER switch and BYPASS switch) or external input distribution switch. Voltage range: 80V-280V, frequency range: 40Hz-60Hz(50Hz system) or 50Hz~70Hz (60Hz system).
- Step 2 Connect the parallel wires, close the POWER and BYPASS switch of the UPS. Close the POWER switch and BYPASS switch of all UPS (keep the OUTPUT switch of all UPS stay in OFF status). If the input power is normal, the rectifier will start automatically, and the touch screens begin to start.
- Step 3 Connect the battery to parallel system.
- Step 4 After the monitor interface of each UPS without abnormal alarm, close the battery input breaker of each UPS (if there are many groups battery, it needs to close the switch of each battery group, and then close the total breaker between UPS and battery groups). Measure the voltage of battery breaker by multimeter (if there are many groups battery, measure the voltage of each battery group, and then measure the voltage of total battery breaker). Ensure that the battery connection is normal (the “battery circuit abnormal” alarm on the main page of touch screen disappear in 2min)
- Step 5 Check if the system alarms are all disappeared. If there is any fault alarm, please suspend startup operation and inform serviceman to solve the problem till all faults are removed.
- Step 6 Start the inverter of each UPS. Ensure that each UPS stay in bypass power supply and the system has no abnormal alarm, start the inverter of each UPS manually, all UPS turn to inverter supply power.
- Step 7 Measure the output voltage and frequency of each UPS. After each UPS turns to inverter power supply (user can check whether the system stay in inverter power supply mode by system running status chart), check whether the UPS three-phase output voltage and frequency is normal by the real-time data in touch screen, measure the front-end three-phase output voltage of output breaker in

output distribution cabinet or external output distribution breaker, ensure that the inverter output voltage is normal (the three-phase output voltage = output voltage setting $\pm 2V$), and ensure that the inverter frequency is normal (the three-phase output frequency = output frequency setting $\pm 0.1Hz$). Record the measured three-phase voltage effective value of each UPS).

Step 8 Compare the output voltage of each UPS. After measuring the output voltage and frequency of each UPS, compares the output voltage of each UPS, ensure that the phase voltage effective value difference of any two UPS less than 5V, and then the parallel operation can be done. If it does not meet the requirement, the UPS with big voltage deviation cannot put into parallel system, and it is necessary to debug again.

Step 9 Shut down the inverter of the UPS. Ensure that there is no abnormal alarm of each UPS, shut down each UPS manually. All UPS turn to bypass power supply.

Step 10 Check the bypass phase sequence.

Close the OUTPUT switch of UPS1 (ensure that the total breaker of load is disconnected, or once closing the OUTPUT switch of UPS1, it will supply power for load), maintain the OUTPUT switch of other UPS disconnected, keep the multimeter in AC position, one pen connect with the output switch front-end phase-A of UPS2, the other pen connect with the output switch back-end phase-A of UPS2, measure the voltage different between front-end and back-end of UPS2 output switch. Measure the voltage difference of phase-B and phase-C as the same way. If the phase sequence is right, the voltage different of each phase should be less than 5V; if the phase sequence is not right, there is at least one phase voltage difference greater than 5V. Measure whether the bypass sequence of each paralleled UPS is right (when measure other UPSs' phase sequence, it doesn't need to operate the switch. Maintain the OUTPUT switch of UPS1 is closed and the OUTPUT switch of other UPS is not closed). If all bypass phase sequence of all UPS is right, go on next step; if the phase sequence of any UPS is not right, power off the system and check the input and output wiring of each UPS and see if the connection is right.

Step 11 Close the OUTPUT switch of all UPS.

Ensure that each UPS with no abnormal alarm, close the OUTPUT switch of all UPS successively. Ensure that the output end of all UPS stay in parallel status.

Step 12 Start the inverter of each UPS.

Ensure that the system is with no abnormal alarm, manually start the inverter of each UPS successively. System starts inverter power supply. Monitor that there is no abnormal alarm.

Step 13 Shut down the inverter of each UPS.

Ensure that each UPS with no abnormal alarm, shut down the inverter of all UPS, the system turns to bypass power supply.

Step 14 Close the total output breaker of load.

After the parallel system turns to bypass power supply, close the total output breaker of load, system bypass supplies power for load.

Step 15 Start each UPS successively, the system will turn to inverter power supply.

----End

5.4.2 Shutdown Parallel System



CAUTION

If the system bypass is normal, after shutting down the UPS, the system will turn to bypass power supply mode; if the system bypass is abnormal, after shutting down the UPS, the system will turn to no output mode, the system output is outage.

Before shutting down, please ensure that load is closed and can endure the status of power outage at any time.

Step 1 Close the load of parallel system, keep the UPS run without load for a while to eliminate inner heat.

Step 2 Perform *5.3.3 UPS Shutdown* to close all UPS, system turns to bypass power supply.

Step 3 Disconnect the load total breaker, each UPS OUTPUT switch, battery breaker, BYPASS switch, POWER switch successively.

----End

NOTE

If it just needs to close the inverter of the UPS, system turns to bypass power supply and the load without power outage, just perform Step 2; if it needs to power off all UPS system, perform all above steps.

5.4.3 Emergency Power Off (EPO)

Single UPS running

Press the EPO button of the UPS or the EPO button of total system, the UPS will shut down and close all output.

Multi UPS running in parallel

- EPO linkage is enabled

Press the EPO button of the UPS or the EPO button of total system, all the paralleled UPS will shut down and close all output.

- EPO linkage is not enabled

Press EPO button of one UPS, the output of this UPS will be closed.

Press the EPO button of total system, all paralleled UPS will be shut down and all output will be closed.

6 Maintenance and Troubleshooting

This chapter mainly introduces the UPS maintenance guide, battery daily maintenance, battery replacement announcement and troubleshooting, etc.

6.1 Maintenance Guide

Proper maintenance is the key to make the device operate in best status and with a longer service life.

6.1.1 Safety Precautions

To ensure human safety and equipment security, observe the following precautions.

- Please keep in mind that there is dangerous voltage inside the UPS even if the UPS does not operate. Before maintenance, use a multimeter to check the voltage and make sure that the UPS is completely shut down and stays in safe status.
- Before close the battery breaker at any time, use a multimeter to measure if the voltage of wiring terminal is normal and the polarity is reverse connected. If the result is abnormal, it is strictly forbidden to close the battery breaker.
- Do not wear any conductive metal objects during operation, such as ring, watch.
- Observe safety regulations strictly. If any doubt, consult professionals.

6.1.2 Preventive Maintenance

To improve the reliability and efficacy of the UPS, perform the following maintenance tasks on a quarterly basis.

- Keep the operating environment free from dust and chemical pollutants.
- Check if the wiring terminals on input, output cables are in good contact every half year.
- Check the fans work status periodically and avoid sundries blocking the air vents. If a fan is damaged, maintain it or replace it in time.
- Check the voltage of batteries periodically, ensure that the battery voltage is within the normal range.

- Check the UPS status periodically and ensure that any fault can be found in time.

6.2 Battery Maintenance

- Battery charge requirements
 - When first use the battery, please start the UPS and charge the battery for 24h. during charging, the UPS still can be used, but if power outage occurs at the same time, the battery discharge time may less than the standard vale this time.
 - Generally, the battery needs to be charged and discharged every 4 to 6 months. First, discharge till battery low-voltage alarm and then charge the battery. The charge time of each time cannot less than 24h.
 - In high temperature area, the battery needs to be charged and discharged every 2 months and the charge time of each time cannot less than 24h.
 - If the battery will not be used for long time, it also needs to charge the battery every 3 months and the charge time of each time cannot less than 24h.
- Clean battery shells by cloth. Oil and organic solvents, such as petrol and diluents are prohibited.
- To avoid explosion, keep batteries far away from fire sources and devices that easily generate sparks.
- Avoid over-discharge the battery during using. Fully charge the battery immediately after discharge (24h at latest) and then the battery can discharge again. It is strictly forbidden to discharge the not fully charged battery, or, it will cause battery capacity decrease even damage battery.
- To avoid battery discharging for too much time after mains power outage, disconnect the battery breaker when the UPS is not used.

6.3 Announcementsfor Battery Replacement

- Do not put the battery into fire, which is to avoid explosion.
- Do not open or disassemble the battery, for the inner electrolyte is harmful for skin and eyes.
- Recycle the battery according to the relative illustration on the battery.
- The battery should be replaced in whole group, do not use the new battery and old battery together.

- A new battery should be with the same capacity, model, and manufacturer as the replaced one. The battery with different capacity, different type and different manufacturer battery is strictly forbidden to use together.
- Dangerous voltage may exist in the battery terminal and grounding terminal, before touching, please measure if there is dangerous high voltage, which is to avoid endanger human safety. It is strictly forbidden to touch the two wiring pillars or the bare end of battery.

6.4 Troubleshooting

6.4.1 Common Abnormal Phenomena Diagnosis

If the UPS works abnormally after start, please refer to Table6-1 to find possible reason. Meanwhile, check whether the fault is caused by external environment, such as temperature, humidity is not accordance with the requirement or overload.

Table6-1only includes some simple diagnosis. If the diagnosis is not clear, or not sufficient to solve the problem, please contact with local agency or dealer to deal with.

Table6-1 Troubleshooting

NO	Abnormal phenomena	Possible reason
1	Mains normal, but UPS works in battery inverting status, the buzzer beeps intermittently.	Each connection point, socket of grid circuit is not so good, which causes the AC power supply input blocked.
2	After installation, close breaker or power supply switch, the fuse will fuse or trip off.	The three-phase input wire is wrongly connected, such as neutral wire and ground wire or live wire and grounding (case) is wrongly connected or the three-phase output wire is wrongly connected.
3	After startup, the UPS outputs 220V AC power, but the UPS works in bypass status.	<ol style="list-style-type: none"> 1. The load it too large and exceed the rated output capacity of the UPS. It needs to reduce load or select a UPS with larger output capacity. 2. If it is temporary bypass caused by the impact of load startup, and it can recover to normal automatically, that is normal.

NO	Abnormal phenomena	Possible reason
4	The UPS output normally after startup, but once turn on load, the UPS stop outputting immediately.	<ol style="list-style-type: none"> 1. The UPS is serious overload or the output circuit is short-circuit. It is necessary to reduce load to proper capacity or find the reason of short-circuit. Common reason is output socket is short circuit or input short circuit caused by device damage. 2. The load is not started according to the sequence from large power device to small power device. You should restart the UPS. After the UPS run stably, start the load according to the sequence from large power device to small power device.
5	The UPS work normally after startup, but some time later, the UPS shut down automatically.	<p>At the status of battery supply power, the battery is runs out and system protects for battery under-voltage, the UPS shut down automatically. This phenomenon is normal. Once mains normal, system will start and charge battery automatically.</p> <p>Warning: if the battery stays in under-voltage status for long time, it will influence the battery service life. After battery under-voltage protection, if mains cannot recover in a long time, please disconnect the battery breaker to protect battery and restart the UPS and fully charge the battery once mains recovers.</p>
6	After startup and work for a long time, buzzer long beeps and the touch screen shows battery low-voltage.	The grid voltage is too low, and the UPS works in battery inverting status, finally, the battery is under-voltage and causes under-voltage protection.
7	When there is mains, the UPS output normally, when there is no mains, the UPS is with no output.	<ol style="list-style-type: none"> 1. Battery fault or the battery group is serious damaged. 2. Charger fault. The battery cannot be charged and causes battery energy insufficient. 3. Battery wire is not well connected or the contact of wire terminal is not good. 4. Battery breaker is not closed. 5. After serious overload, the UPS is not restarted, which causes the UPS stay in bypass output status.

NO	Abnormal phenomena	Possible reason
8	Buzzer long beeps, the UPS turns to bypass supply power.	See the fault information on touch screen.
9	There is mains, but buzzer beeps intermittently.	The mains voltage or frequency exceed the allowable range of the UPS.
10	At mains status, the UPS works normally, once power outage, the UPS works normally but load system halt.	The grounding is not so good and the float voltage between neutral wire and grounding wire is too large.
11	FAULT indicator of a power unit is on.	The power module is fault, replace it in time.

6.4.2 Emergency Dispose for System Fault

- How to deal with the system fault in emergency

When system fault, shut down the power supply of UPS by the touch screen, if necessary, close the user load and disconnect the input and output switch of the UPS to avoid further damage for the UPS. Inform the engineering technician to maintain.

- How to deal with the fault of single power module in emergency

When some power module fault, it will be insulated with system automatically. Generally, it will not influence the system normal operation, but it will decrease the redundancy degree of the module. At this time, please shut down the fault module and pull it out of the cabinet, and then inform the engineering technician to maintain.

After pulling out the module, there still has high voltage inside the module and on the rear connector pin. It is necessary to wait enough time ($\geq 10\text{min}$) and then open the cover to maintain.

7 Package, Transportation and Storage

This chapter mainly introduces the package, transportation and storage of the UPS.

7.1 Package

During packing, please pay attention to the place direction requirements. At the side of the package, there is afraid of wet, handle with care, upward, stack layer limit, etc. alarm marks. And also, the device model is printed on the package. At front of the package, the LOGO of Power Solid Company and device name is printed.

7.2 Transportation

During transporting, pay attention to the warning marks and avoid severe impact on the device. Place the device according to the marked direction, which is to avoid damage the component. Any inflammable, explosive, corrosive object is not allowed to shipping with the device. While midway transportation, do not put the device in the open air. The device cannot suffer any rain, snow or liquid material or mechanical damage.

7.3 Storage

When storing the device, place the device according to the marked direction. The package box should be far away from ground for 200mm, and keep at least 500mm from wall, eat source, cold source, window or air inlet.

Storage temperature: $-25\sim 55^{\circ}\text{C}$. If the device is transported or stored out of the storage temperature, before installation and startup, put the device aside and let the device temperature recover to normal range for more than 4h. In the warehouse, any inflammable, explosive, corrosive object or harmful gas is not allowed, and also, strong mechanical shake, impact or magnetic field is forbidden. The storage period of these requirements, generally, is 6 months. If the device stored more than 6 months, it is necessary to check again. If the device is stored for a long time, please charge the battery every 3 months.

A Technical Specifications

Index \ Model		MR33	MR33	MR33	MR33	MR33	MR33	MR33
		75	125	200	300	400	500	600
Input	Input mode	3 ϕ 4W+PE						
	Rated input voltage (VAC)	220/230/240 (phase voltage)						
	Input voltage range	Vin=176Vac~280Vac, it does not need to decrease rated power to use Vin=80Vac~175Vac, for linear load, it is necessary to decrease rated power to use						
	Input frequency range (Hz)	40~70						
	Bypass synchro tracking range (Hz)	50/60 \pm 6						
	Bypass input voltage (VAC)	220/230/240 (phase voltage)						
	Input power factor	\geq 0.99						
	Input THDi	Resistive full load: \leq 3%; non-linear full load: \leq 5%						
	Battery voltage (VDC)	\pm 180~ \pm 276 (can be selected in the range of \pm 15 pieces to \pm 23 pieces, for PS75KVA, PS125KVA and PS200KVA, the default is \pm 16 pieces, for other models, the default is \pm 20 pieces)						
	Charge current (A)	Power module amount *10 (max)						

Index		Model	MR33	MR33	MR33	MR33	MR33	MR33	MR33
		75	125	200	300	400	500	600	
Output	Output mode	3 ϕ 4W+PE							
	Output wave-form	Sine-wave							
	Voltage (Vac)	L-N: 220/230/240 L-L: 380/400/415							
	Frequency (Hz)	When mains normal, it tracks the bypass input frequency; When mains abnormal, it tracks the frequency $50 \pm 0.2\%$ or $60 \pm 0.2\%$ of the UPS.							
	Three-phase phase position error	With balance load $\leq 1^\circ$							
	Wave form distortion (THDv)	Linear load $\leq 1\%$; non-linear load $\leq 4\%$							
	Bypass inverter transform time (ms)	Synchro: 0; Unsync < 15							
	System efficiency	96%							
	Overload capacity	<ul style="list-style-type: none"> ● For less than 105% load, it runs for long-term; ● For 106% ~ 110% load, it turns to bypass after 60min ● For 111% ~ 130% load, it turns to bypass after 10min ● For 131% ~ 150% load, it turns to bypass after 1min ● For 151% ~ 250% load, it turns to bypass after 200ms 							
	Dynamic response transient range	The load changes in the range of 0% ~ 100% or 100% ~ 0%, the dynamic response transient range of output voltage $\leq 5\%$							
	Load unbalance capacity	Can bear 100% unbalance load							
	Manual maintenance bypass	Equip the maintenance bypass switch of no switch time							

Index \ Model		MR33	MR33	MR33	MR33	MR33	MR33	MR33
		75	125	200	300	400	500	600
Others	DC startup function	Equipped						
	Touch screen display	Three-phase input voltage, input frequency, three-phase output voltage, load, battery voltage, battery charge/discharge current, output current of each module and inner temperature, parameter setting, history record, etc.						
	LED display	UPS work status and overload alarm indication						
	Alarm function	Alarm for input abnormal, battery low-voltage, overload, fault, etc.						
	Communication function	Provide dry contact communication, RS232, RS485, MPDBUS and it can select SNMP optional to realize the smart monitor for the UPS. (options of RS232, RS485, SNMP supports SNMP protocol. MODBUS supports MODBUS protocol)						
	Battery monitor function (optional)	It can select BMS2000 battery monitor management system to realize the monitor for the work status of single cell						
	Protection function	Protect for output short-circuit, output over-voltage/ under-voltage, overload, over-temperature, battery under-voltage, etc.						
	EMC	Meet the provision of GB7260.2-2009						
	Cooling way	Forced wind-cooling						

- Specifications are subject to change without prior notice.

B Physics Characters

B.1 Physics Characters

Model Item	PS75KVA	PS125KVA	PS200KVA	PS300KVA
Wiring way	Supports wiring from upside and downside (The default is the downside)	Supports wiring from upside and downside (The default is the downside)	Optional wiring from upside and downside (it cannot be changed in customer site)	Supports wiring from upside (wiring from downside is optional)
Weight(kg)	Cabinet without module: 155 Power module: 33 Bypass module: 20	Cabinet without module: 162 Power module: 33 Bypass module: 20	Cabinet without module: 224 Power module: 33 Bypass module: 23	Cabinet without module: 236 Power module: 33 Bypass module: 27
Size (W×H×D) (mm)	600×2000×860	600×2000×860	600×2000×860	
Noise(dB)	<65	<65	<70	
Protection grade	IP20			
Communication function	Dry contact, RS232, RS485, MODBUS , SNMP (optional)			
Work temperature (°C)	0~40			
Storage	-25~55			

Model Item	PS75KVA	PS125KVA	PS200KVA	PS300KVA
temperature (°C)				
Relative humidity	0% ~95% RH (with no condensation)			

B.2 Physics Characters

Model Item	PS400KVA	PS500KVA	PS600KVA
Wiring way	Supports wiring from upside and downside	Supports wiring from upside and downside	Supports wiring from upside and downside
Weight(kg)	Cabinet without module: 427 Power module: 33 Bypass module: 27	Cabinet without module: 427 Power module: 33 Bypass module: 31	Cabinet without module: 427 Power module: 33 Bypass module: 31
Size (W×H×D) (mm)	1200×2000×860		
Noise (dB)	<70		
Protection grade	IP20		
Communication function	Dry contact, RS232, RS485, MODBUS , SNMP (optional)		
Work temperature (°C)	0~40		
Storage temperature (°C)	-25~55		
Relative humidity	0% ~95% RH (with no condensation)		

C Acronyms and Abbreviations

A

AC Alternating Current

D

DC Direct Current

DSP Digital Signal Processor

E

ECO Energy Control Operation

EPO Emergency Power Off

L

LED Light-emitting Diode

P

PE Protective Earthing

R

RS232 Recommend Standard 232

RS485 Recommend Standard 485

S

SNMP Simple Network Management Protocol

T

THD_v Total Harmonic Distortion of output voltage

U

UPS Uninterruptible Power System