

**3KVA**

**ONLINE UPS (DUAL OUTPUT)**

---

**PS-P0U3KD#8B9K**

**USER MANUAL**



## 【NOTE】

Please carefully read the user's manual before operation for the sake of understanding correct operation of the instrument. Please keep the manual handy for future reference.



### WARNING



The input and output of the instrument is with danger high voltages which may endanger the safety of life. Please strictly follow the operating description is not allowed to remove the cover of the instrument.

1. Please connect protective earth before power supply cables.
2. The input & output voltage of the UPS is dangerous which will endanger the safety.
3. Dangerous voltages are present inside the unit. Please do not open the cover of the UPS.
4. Please turn off the mains input switch and the battery switch for any urgency.
5. There are many kinds of power sources in the equipment, the line bank or the socket may still have dangerous voltage even if the main power is disconnected.
6. Please remove the cable between the battery & UPS before repairing. It's necessary to wait for another 5 minutes for discharging, because of the dangerous voltages.
7. The wires should be fastened to the terminals. It is prohibited to short the anode and cathode of battery. It's prohibited to touch any two of wire connectors or bare end of connecting wires. Otherwise, it may lead to damage of battery or personal injury.
8. Please keep the battery away from the fire and all the equipment that may cause spark to prevent the danger and damage.
9. Please do not open or shatter the battery, the overflow electrolyte is with causticity that may be harmful to life.
10. Please contact the professional personnel of the local dealer or the special maintenance station for any trouble-shooting. Random disposal of the trouble is not allowed.
11. This is an A-grade product with electromagnetic compatibility.
12. This equipment must be installed and serviced by qualified personnel.
13. Before you replace the battery of different brand and different type, make sure the charging voltage is matching with UPS charging voltage due to the different required charging voltage of different battery, If any doubt, please consult with the manufacturer. Any changes of the system configuration, structure and composition will influence the performance of UPS, please consult with the manufacturer in prior before doing any changes.
14. Before usage, confirm that the temperature of the instrument has dropped into the normal run range. It is recommended still placement for 24 hours in the normal temperature range before startup.

# Contents

1 .Overview.....	1
1.1 Profile.....	1
1.2 Performance Index .....	2
1.3 Primary Functions and Characteristics .....	3
1.4 Precautions.....	3
2 .Structure and Basic Principles .....	5
2.1 General Structure .....	5
2.1.1 Display Structure and Display Interface of ( 3kVA) Series .....	5
2.1.2 3KVA Front Panel, Rear Panel Structure .....	6
2.2 Basic Principles .....	7
3 .Equipment Installation .....	9
3.1 Site and Environment Requirements .....	9
3.1.1 Site Requirements.....	9
3.1.2 Environment Requirements .....	9
3.2 Procedures of Dismantling Cases.....	10
3.3 Installation of UPS .....	10
3.4 Selection of Cable .....	11
3.4.1 Selection of Input Air Switch .....	11
3.4.2 Selection of Input and Output Power Cord Diameter .....	12
3.5 Cable Connection .....	13
3.5.1 13KVA .....	13
3.5.2 Inspection of Electric Connection .....	15
4 . Equipment Use and Maintenance.....	16
4.1 Preparations before First Start-up .....	16
4.2 UPS Start-up Sequence .....	16
4.3 Daily Start-up and Shutdown.....	17
4.4 Battery Daily Maintenance .....	17
4.5 Battery Changing.....	18

4.6 Maintenance Guide .....	18
4.6.1 Safety Precaution.....	19
4.6.2 Preventive and Regular Maintenance.....	19
4.6.3 FAQ .....	20
4.7 Troubleshooting .....	21
4.7.1 Overview .....	21
4.7.2 Troubleshooting.....	22
5 . Packing, Transportation and Storage.....	23
5.1 Packing .....	23
5.2 Transportation.....	23
5.3 Storage .....	23

# 1 .Overview

## 1.1 Profile

3KVA UPS is total high frequency, pure online and intellectualized UPS. They are also ideal power guarantee for file server, enterprise erver, central server, microcomputer, concentrator, telecommunication system, data center, medical facilities and those requiring high quality power protection. They can be widely used in many key business areas such as post & telecom, finance, network, securities and railway, etc.

3KVA UPS is single-phase alternating current input and output.

## 1.2 Performance Index

The main performance index of 3KVA is shown in Table 1-1.

Table 1-1 UPS Main Performance Index

Index	Model	3KVA	
Input Characteristic	Rating voltage (V)	160V~290 100%LOAD, 120V~160 50%LOAD	
	Rating frequency (Hz)	50±5%Hz(60±5%Hz)	
	Input mode	Single-phase three-line	
	Battery voltage (V)	96	
Output Characteristic	Capacity (VA/W)	3000/2400	
	Voltage (V)	120±2%/220±2%	
	Frequency (Hz)	50±0.2Hz or 60±0.2Hz (Battery mode)	
	Waveform	Sine wave	
	Voltage distortion factor	THD < 3% (Linear load)	
	Power factor	0.8 (Lag)	
	Switching time (ms) AC-BATTERY	0	
	Overload capacity	105%~130% Load, lasting 60 seconds. 135%~150% Load, lasting 30 seconds	
	Output mode	Sockets	
	Other Characteristics	Spare time	5 minutes (PC LOAD)
Charge recovery time		<12 hours (Standard time delay model)	
Communication interface		RS232 interface supports UPS power management software or SNMP protocol	
Panel display		LCD and LED display operation status and function of UPS	
Warning function		Battery low voltage, abnormal power supply, UPS malfunction, Over load	
Protection function		Battery low voltage protection, overload protection, short-circuit protection and over temperature protection	
Frequency noise (dB)		< 45	
Working temperature		0 ~ 40℃	
Relative humidity		0 ~ 95%, No condensation	
Size (mm) (H × W × D)		347×198×670	
Weight (kg)		46	

◆ Specifications are subject to change without prior notice.

---

## 1.3 Primary Functions and Characteristics

1. Intelligentized RS232 communication function: With RS232 standard data interface and UPS power management software, realize three remote-control functions between computer and UPS, computer supervises UPS operation and electric parameters, and realize long-distance power on/off function, as well as supporting SNMP network adaptor (outlaid, connecting UPS through RS232 interface), which enables UPS to directly become network fresh blood.
2. High input power factor: Adopt advanced active PFC technique, which alleviates load on electric network and represents green power supply of new generation.
3. High performance-price ratio: Adopts multiple power transfer and high frequency PWM technique, high efficiency, small size and light weight as well as improving operational reliability and reducing manufacturing cost, which lowers the cost of the system design for customers.
4. Perfect protection function: Possess such functions as output low-voltage protection, battery low-voltage protection, input low-voltage protection and triple overflowing protection, etc and overcome previous defects such as high frequency UPS' poor adaptability and weak resistance to shock for electric network.
5. Low commercial power input voltage: Adopt independent quick detection technique, even at the lower limit 140V of commercial power, the battery remains off discharge, thus all energy output are taken from electric network, ensuring the battery in the state with 100% energy storage, while at the same time decreasing the battery discharge times and prolonging its life.

## 1.4 Precautions

Abide by the following general safety precaution during operation or maintenance.

1. Please don't remove the cover. This system can only be maintained or repaired by professional maintenance personnel.

- 
2. Protective ground terminals should be connected to earth end for sure.
  3. High creepage danger! Connect to the ground before connecting UPS.
  4. Install this UPS indoors with both temperature and humidity under control and without dust.
  5. The electric power of this UPS has multiple sources. Before maintaining, cut the alternating current, exterior battery or interior battery's air switch to isolate the input energy.
  6. Even if the AC power supply has been cut off, the danger from battery's high voltage inside the UPS still exists.
  7. If battery circuit has not been isolated from AC input, dangerous voltage may possibly exists between battery terminal and ground terminal.
  8. High voltage endangering personal safety exists in the storage battery of this UPS. Please pay attention to insulation during installation and use.
  9. Improper handling of acidic battery leads to leakage risk of chemistry dangerous substance and corrosive liquid.
  10. Dripping condensation should be happen if machine was operated under low-temperature environment. So please install and use machine when machine was full-dry, or there will has dangerous of electric shock.

**Warning:** Input and output voltage of this equipment is dangerous high voltage, which can endanger personal life or safety. Please read carefully this Manual during installation, operation and before use. Pay attention to various caution nameplates and caution statements. Professional maintenance personnel without proper authorization are not allowed to remove off the case cover of this equipment.



## 2 .Structure and Basic Principles

### 2.1 General Structure

#### 2.1.1 Display Structure and Display Interface of (3kVA)

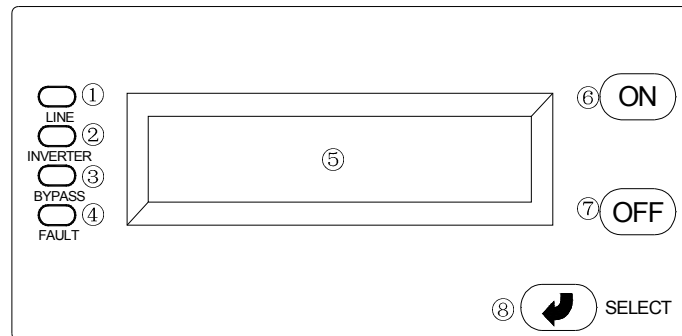

Fig. 2-1 Display panel interface of (3kVA) Series

#### Explanation :

- ①、Line light
- ②、Inverter light
- ③、Bypass light
- ④、Fault light
- ⑤、LCD Display panel
- ⑥、ON button(Press "ON" button for 0.5 seconds to start up UPS )
- ⑦、OFF button (press it Press "OFF" button for 0.5 seconds to shut down UPS.)
- ⑧、Select button

press the key "ON" for 3 seconds to test the battery when start up the UPS under the unititly mode; press the key "ON" for 3 seconds to make the buzzer silent when start up the UPS under the battery mode.if it need to display the history or return, please press the select key for 3 seconds;if it need to delete the history, please press the select key on the history page(or on the output display page when the backlight lights out) for 6 seconds

## 2.1.2 3KVA Front Panel, Rear Panel Structure

Front and rear panel structure of the main unit of 3KVA and is illustrated in Fig. 2-3. Inside which the switch on rear panel is composed of switch for commercial power input and switch for storage battery.

The upper switch is for storage battery, and the lower one is for commercial power input.

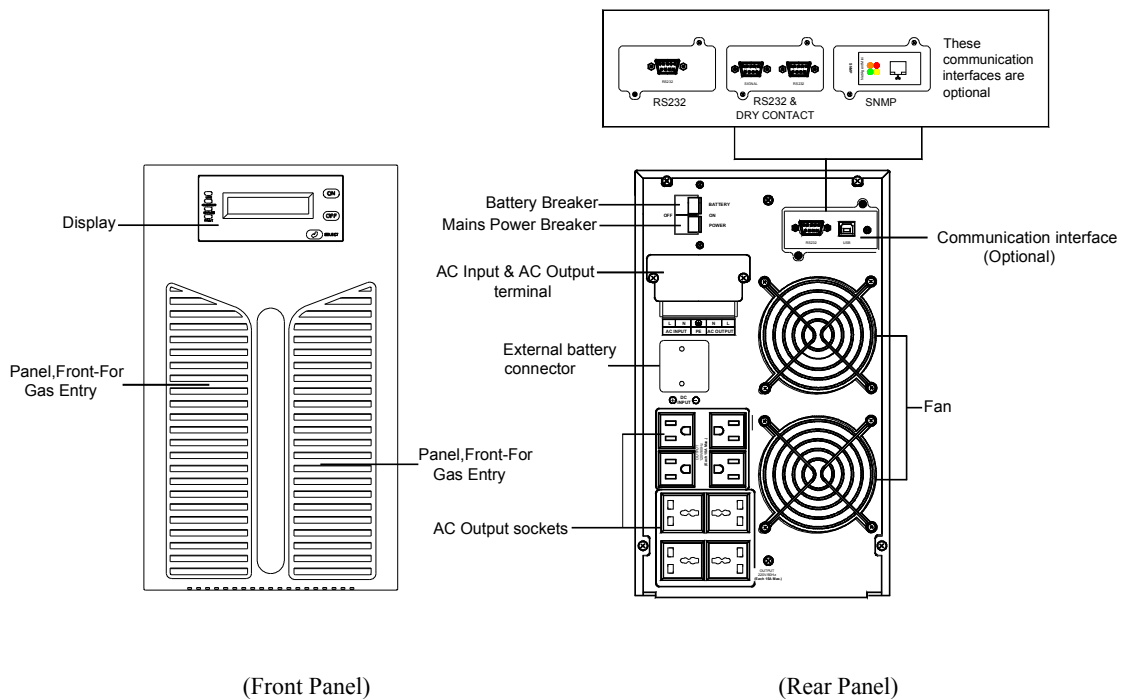

Fig. 2-3 3KVA Front Panel and Rear Panel Structure

---

## 2.2 Basic Principles

When commercial power is normal, (3kVA) UPS input, through PFC, increases the voltage to  $\pm 370\text{V}$  stabilized DC voltage, which supplies DC/AC inverter and transmits stable 220VAC, while at the same time completing the charging of the battery. When commercial power is abnormal, the battery increases the voltage through DC/DC to  $\pm 390\text{V}$  DC voltage and supplies DC/AC inverter.

UPS principle block diagram is shown in Fig. 2-4. DC/AC inverter adopts half-bridge structure, while DC/DC voltage increase adopts push-pull or BOOST circuit. PFC is active power-factor correction circuit controlled by UC3854, while CHARGER is complete isolation type charger.

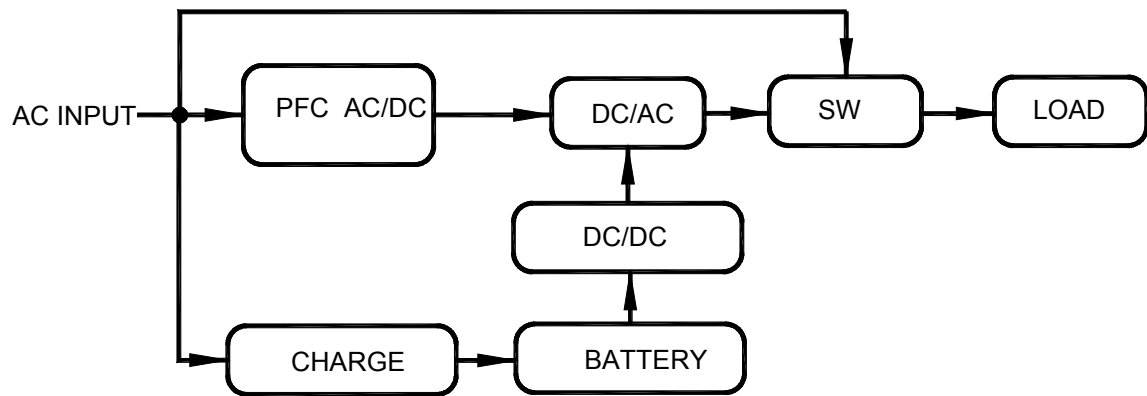

Fig. 2-4 UPS Basic Principle Block Diagram

Corresponding relations of pins for the RS232 serial ports of this series UPS and those of general PC are shown in Table 2-1.

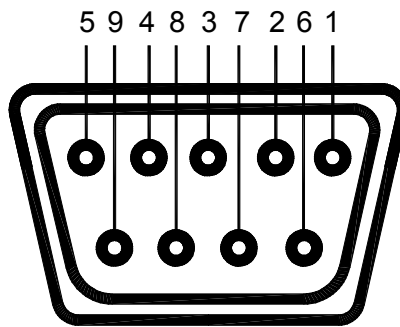

Fig. 2-5 RS232 pins definitions

Table 2-1: Corresponding relations of pins for the RS232 serial ports of this UPS and those of general PC:

Communication RS232 Interface for UPS	General RS232 Interface
9 (3)	2 (Receive)
6 (2)	3 (Deliver)
7 (5)	5 (Ground)

# 3 .Equipment Installation

## 3.1 Site and Environment Requirements

Before UPS installation, the site and environment of equipment room should meet the essential conditions for safe and normal operation of equipment as defined in this section. If the customer's site conditions are not accord with the minimum requirement of safe equipment operation, the customer should make corresponding changes to the site conditions, and install the equipment only after meeting the conditions of safe and normal equipment operation.

### 3.1.1 Site Requirements

The site conditions should accord with the essential conditions of safe and normal equipment operation as stated in this section.

1. The equipment room must be equipped with applicable and effective fire apparatus;
2. The commercial power, which supplies power for UPS, should be equipped with dedicated air switch or utility socket;
3. Strictly prohibit to store dangerous things, such as inflammable things, explosive things in the equipment room;
4. Before equipment installation, the ground wire should be prepared. The voltage of neutral wire and ground wire of commercial power cannot exceed 5V;
5. The civil engineering construction of the equipment room should be completed totally, and the floor should be sclerotic. The site must be tidy and dry without dust.

### 3.1.2 Environment Requirements

Ambient temperature: 0°C~+40°C;

Relative humidity: 0%RH~95%RH, no condensation;

Cooling mode: air-cooling;

Verticality: no shock with orthogonal rake not exceeding 5°.

---

## 3.2 Procedures of Dismantling Cases

When installing the equipment, the packing should be removed after carrying the equipment to the installation site. The packing of UPS equipment and fittings (battery, etc.) should be wooden case and carton. Check the UPS equipment and fittings against the shipping list.

If the equipment or fittings are damaged during transportation or the equipment and fittings are not accord with the ordering contract, make site record in time and immediately contact the local office or distributors.

Refer to Table 3-1 for the equipment configuration.

Table 3-1 List of Equipment Configuration

Item	Description	Unit	Qty.	Remarks
1	AC wire	Piece	1	3KVA is line bank
2	Fuse	Piece	1	3KVA N/A
3	Software	Set	1	Optional
4	User's Manual	Copy	1	Enclosed in grip bag
5	Packing list	Copy	1	Enclosed in grip bag
6	Warranty Card	Copy	1	Enclosed in grip bag
7	Battery expansion line	Piece	1	Standard time backup model N/A

## 3.3 Installation of UPS

Because the main unit size of (3kVA) standard time-delay model and long time-delay model is small, the UPS can be placed on the flat surface directly without other fixing or installation. For convenient operation, maintenance and heat emission of the equipment, there shall be at least 30cm~50cm room space reserved around the machine frame and 50cm above the upper machine frame. The vent fan shall be installed beside the battery. Keep good interior ventilation. The service life of the battery is the longest when the battery is used under normal temperature(20℃). Recommend to install air-conditioning equipment in equipment rooms with allowed conditions. Refer to Fig. 3-1 for the precautions of UPS installation and use.

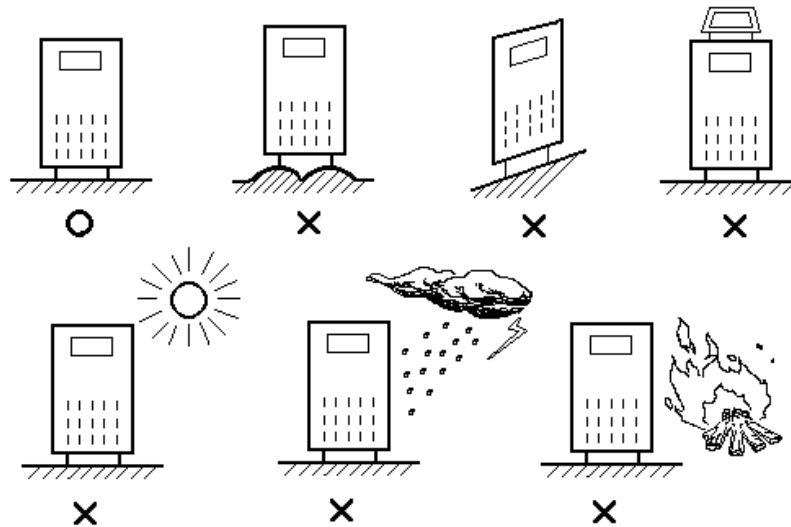

Fig. 3-1 Precautions of UPS Installation and Use

1. Place UPS on flat floor (avoid oblique and ragged floor).
2. Keep good ventilation, the distance of the back and side to the wall should be above 30cm~50cm, to facilitate heat emission.
3. Avoid placing it in the location with sunshine, rain and dampness.
4. Never place it in the location with corrosive air.
5. Do not place articles on or around the UPS, to prevent the vent hole from being blocked. No person is allowed to sit on it.

## 3.4 Selection of Cable

### 3.4.1 Selection of Input Air Switch

Before the input coil in of the equipment, install an air switch or a distribution box compliant with the power and capability of the equipment, to isolate it with commercial power. Consider especially the charge power and the current shock, the input air switch can be higher than 1.5-2 times most current of UPS input, which is without leakage current protection in order to avoid error action. The distribution box should be better to be manufactured by professional company. Please refer to Table 3-2.

Table 3-2 Recommended Sectional input air switch

	3KVA	
	Most Current (A)	Recommended Air switch (A)
AC Input	23	32
DC Input	35	50

### 3.4.2 Selection of Input and Output Power Cord Diameter

For the selection of conducting wire sectional area for UPS AC input and output cable and battery cable, please refer to Table 3-3 for corresponding recommended values, and choose values upwards.

Table 3-3 Recommended Sectional Flow of Cable Sectional Area of UPS

Ampacity (A)	Sectional Area (mm <sup>2</sup> )							
	1	1.5	2.5	4	6	10	16	25
Rubber (25°C)	8	12	20	28	42	70	96	125
Plastic (25°C)	6	9	15	20	30	50	64	100



### 3.5 Cable Connection

To connect UPS cable only after confirming that all air switches on UPS are in disconnection condition, and the equipment is properly installed.

#### 3.5.1 3KVA

The input and output connection methods of 3KVA

shown in Fig. 3-3.

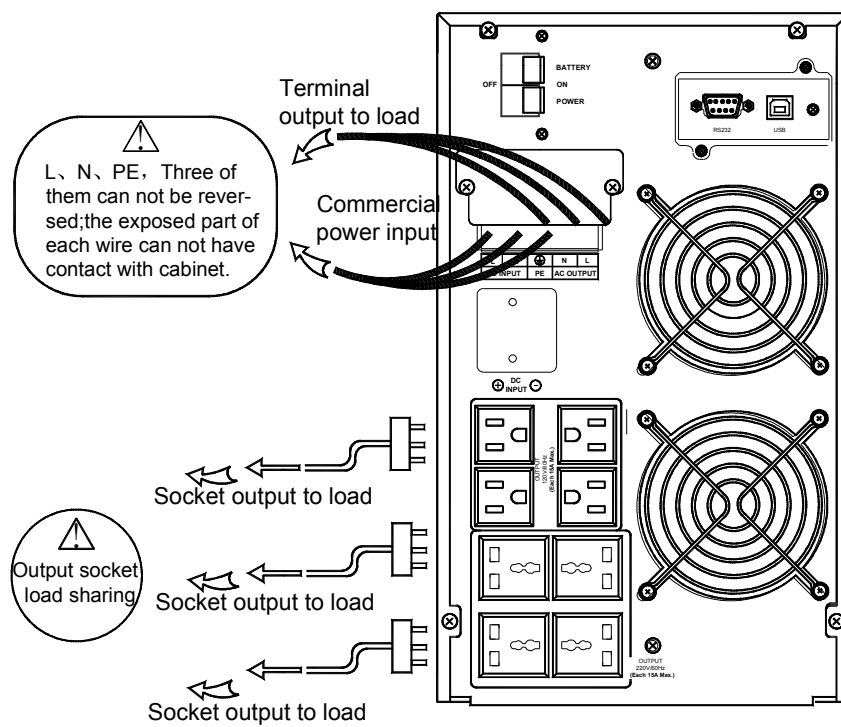

Fig. 3-3 3KVA connection Schematic

---

AC input of 3KVA adopts line bank, and the AC output adopts socket.

You can insert load power cord into the output socket directly.

Normally, the load current of each socket cannot exceed 10A.

When connecting the line bank, take the small cover board off from the line bank, and pay attention to the definition of connection terminal: from the right to the left (rear view) orderly to AC input are: live wire (L), neutral wire (N) and ground wire (PE). After the connection, please check up whether the wire of connection is correct and firm, and then install the small cover board back to the box.

For long time-delay UPS, battery input expansion line is required to be connected. That is, insert the battery connection wire two-core plug of the battery box into the two-core socket on main unit rear panel. Refer to the relevant content of the battery box installation and cable connection.

---

### 3.5.2 Inspection of Electric Connection

1. Inspection of AC input wire: Whether the AC wire color spectrum is normative. Whether the wire diameter of AC input cable is suitable. Whether control switch is connected outside. Whether the connection of live wire (L), neutral wire (N) and ground wire (PE) is correct. Whether the connection of AC input wire is firm.
2. Inspection of AC output wire: Whether the AC output wire color spectrum is normative. Whether the wire size of AC output cable is suitable. Whether switch in the control switch outside. Whether the connection of line wire (L), neutral wire (N) and ground wire (PE) is correct. Whether the connection of AC output wire is firm.
3. Inspection of ground wire: Whether the ground wire of UPS is connected to the ground line bank of the equipment room. Whether the connection of ground wire is reliable.
4. The inspection of the voltage difference between neutral wire and ground wire: the voltage difference should be less than 5Vac.
5. If the customer adopts the configuration of long time-delay model, examine whether the battery cable connection of main unit box and battery box is correct and reliable.
6. If the UPS is installed with remote monitoring equipment, examine whether the connection of relevant RS232 serial port is correct.
7. Examine whether the wiring is in order, whether the cable binding accord with the technical criterion.
8. Examine whether the installation and wiring are in favor of the future system modification, expansion and maintenance.

# 4 . Equipment Use and Maintenance

## 4.1 Preparations before First Start-up

To ensure normal operation of UPS, please confirm the following before use:

1. Correct installation of input and output;
2. If the air switch at the back of UPS is placed at "OFF";
3. If the power end is connected to rated input power supply;
4. Confirm that UPS output does not short circuit, and the load capacity does not exceed UPS capacity;
5. Confirm if computer or other instrument is turned off;
6. Confirm if battery voltage is normal;
7. It is not recommended to connect reactive load to the UPS output. Loads are normally powered by electric network directly.

## 4.2 UPS Start-up Sequence

After confirming all the above, please start the machine by following means:

1. Put the air switch at the back to "ON" position.
2. Press the "ON/OFF" button on the UPS panel to start UPS, the "INV." indicator light will light up. After retardation time, the "BYPASS" light goes out and the UPS is changed inversion power supply. By this time, the start-up is completed and the equipment starts operation. Wait for about 20 seconds after normal no-load operation to turn on the computer or other instrument. Start the load in the sequence of high-power to low power, first start the high-power equipment then in turns start equipment with lower power.
3. Start computer or other equipment.

---

### 4.3 Daily Start-up and Shutdown

During daily operation, operate as per the following for start-up or shut down:

1. Press the "ON/OFF" button on the UPS panel to start UPS, after 10 seconds, turn on the computer or other instrument.
2. Before shutdown, turn off the computer and other instrument first and perform no-load operation of UPS for 10 minutes. After the heat in the equipment has been discharged, press the "ON/OFF" button on the panel.
3. Normally, only when the UPS has been started and is working stably, can the loading equipment power switch be turned on. First turn on high-power equipment, then the equipment with lower power. Some equipment has large start current (such as monitors of some brands). When starting such equipment, overload protection (such as bypass operation) may occur. In this case, it's recommended to start this type of equipment before other equipment.

### 4.4 Battery Daily Maintenance

1. If the equipment has not been used for a long period, it should be charged for more than ten hours.
2. Before operating the equipment, please charge it for ten hours after start-up. The equipment can still be used during charging. If power failure occurs at the same time, this discharge time may be under standard value.
3. Normally, battery will be charged and discharged every four to six months. First discharges until shutdown then charge. The charging time for standard device should be no less than ten hours each time.
4. At high temperature region, the battery should be charged and discharged once every two months. The charging time for standard device should be no less than ten hours each time.
5. Batteries of different capacity, type, and produced by different manufacturers should not be mixed when using.
6. When cleaning battery case, only use wiping cloth and clear water, do not use oil substance or organic solvent such as gasoline and thinner, etc.

- 
7. Battery and battery unit should be kept away from ignition source as well as all electrical equipment that may easily cause spark, to avoid causing unnecessary loss.
  8. During the use of battery unit equipped for UPS, regularly check if the charger is in good condition to prevent the battery from being overcharged or undercharged for a long time, and to avoid excessive discharge of battery. After discharging, immediately (no later than 24 hours) perform complete charging, only after then will the re-discharged be allowed. Never re-discharge if the battery is not completely charged, otherwise it will cause decrease in battery capacity or even damage to battery.
  9. When not using UPS, please turn off the "OFF" switch on the panel to avoid causing long-time battery discharge after commercial power failure. If the UPS has not been used for a long time, regularly perform charging and discharging of battery to avoid battery damage due to self-discharging.

## **4.5 Battery Changing**

When changing storage battery, pay attention to the following:

1. Do not throw battery into fire to avoid explosion.
2. Do not open or disassemble battery as the electrolyte is harmful to skin and eyes.
3. Properly recycle the battery according to relevant instructions thereon.
4. Replace the used battery with new ones that are of same type and grade.
5. Replace the entire battery unit, do not mix the old ones with the new ones.
6. Dangerous voltage may exist between battery terminal and the ground. Test before touching.

## **4.6 Maintenance Guide**

Proper maintenance includes preventive maintenance and remedial aintenance, which is crucial to optimum operation of UPS and can ensure relatively long service life of the equipment. Preventive maintenance includes some procedures that are frequently performed. These procedures are used to prevent system failure as well as to obtain best operating efficiency. Remedial

---

maintenance includes searching for system malfunction to facilitate effective repair.

#### **4.6.1 Safety Precaution**

In order to securely and successfully conduct system maintenance, relevant safety precautions must be observed and necessary tools and testing equipment must be used, with the participation of qualified maintenance personnel. Pay attention to the following safety operation rules:

1. Bear in mind that there is dangerous voltage in UPS even if the UPS system is not in operation.
2. Make sure that the UPS operation and maintenance personnel are familiar with this equipment and the content of this Manual.
3. As operating UPS, do not wear gold or silver jewelry such as ring or watch, etc.
4. Do not take the safety operation procedure for granted. If there is any doubt, consult personnel who are familiar with the equipment.
5. Be cautious that there is dangerous voltage in UPS. Before maintenance and adjustment, use voltmeter to check and ensure that the power is turned off and the equipment is under safe condition.

#### **4.6.2 Preventive and Regular Maintenance**

The following shows the preventive maintenance procedures which will improve UPS system operation efficiency and reliability.

1. Keep the environment clean to avoid dust and chemical contamination to the UPS.
2. Cable connection  
Semiannually check the input and output cable connecting terminals once. Carefully measure and check them to ensure good contact.
3. Check the working status of the vent fan on a regular basis to prevent clogging of the air outlet. Repair it if there is any damage.
4. Perform periodic inspection on battery voltage and UPS working status.

---

### 4.6.3 FAQ

If the UPS fails to work properly after starting, please don't jump to the conclusion of UPS failure. Please refer to the following and try to solve the problem.

#### **Problem 1**

Power supply is normal; UPS is able to output AC 220V after start, yet in the status of battery inversion with buzzer giving intermittent buzzing.

Possible cause: Unstable AC power input as a result of poor contact of the junction points, sockets or other connection parts of the electric network feeder circuit connected to the UPS.

#### **Problem 2**

After UPS is installed, and after the electric brake or UPS "ON" button is switched on, the fuse will be burnt out or tripping occurs.

Cause: wrong connection of three UPS input wires, for example, zero line or fire wire is connected to UPS earth wire (case); or wrong connection of three UPS output wires.

#### **Problem 3**

After UPS is started, it outputs AC 220V, yet it's working under bypass status ("BYPASS" keeping lighted).

Possible cause: too-heavy load sustained by the device which exceeds rated power of the UPS. In such cases, relieve the load to the UPS, or use a UPS of higher rated power capacity. If it is a temporary bypass status caused by start-up impact of the load, and returns to proper status automatically, that's normal operation.

#### **Problem 4**

Display and output of the UPS are normal after start. However, the output stops as soon as load is connected to it.

Cause:

(1)UPS severe overload or output circuit short circuit. Reduce the load to an adequate amount, or check the cause for short circuit. In many cases, it is caused by output adapter short circuit or input short-circuit fault owing to



---

equipment damage.

(2) Failure to follow the load start-up sequence which shall begin with heavy-duty equipment to low-duty ones. Restart UPS and wait till UPS runs stably; first start heavy-duty equipment and then devices of lower duties.

#### **Problem 5**

UPS works properly after start-up, and automatically shuts off after a certain period of time.

Cause: battery unit is not charged in time and is working under battery supply status (not powered or not connected to power grid), thus resulting in battery low-voltage protection of the UPS.

Warning: in the case of UPS battery low-voltage protection, please immediately turn off all switches, and restart the UPS and charge the battery to full capacity when power supply recovers. Long-period low-voltage of the battery will shorten the service life of the battery.

#### **Problem 6**

After working for a certain period, with normal input display, the buzzer gives intermittent buzzing and displays battery low-voltage simultaneously. Cause: too-low power grid voltage makes the UPS work under battery feed status. When the battery runs low and low-voltage occurs, it enters into protection status.

#### **Problem 7**

UPS is started and working. When power supply breaks down, UPS fails to output power.

Cause: the battery unit is not connected to main unit or is severely damaged.

## **4.7 Troubleshooting**

### **4.7.1 Overview**

In the case of device failure, first of all, find out any obvious damage and try to determine what causes the failure: device problem or external environment

---

(such as temperature, humidity and load). Always check these external factors before coming to the conclusion of UPS system damage.

#### 4.7.2 Troubleshooting

Only some simple troubleshooting suggestions are provided here. If the diagnosis result is not certain or the information given here is not sufficient for problem-solving, please turn to your local office or distributor for repair.

1. Buzzer gives long buzzing, trouble light is on, UPS is powered through bypass, and inverter fails.

Possible causes:(1) Output overload or short circuit results in UPS automatic shutdown protection.

(2) Driving or power tube malfunction.

(3) Master control board failure.

(4) UPS Over-temperature protection

2. UPS works properly when power supply is O.K., but it fails to function during power failure.

Possible causes: (1) Battery failure.

(2) Battery charger malfunction: failing to charge battery when power supply is O.K.

(3) Poor contact between battery connecting wires or connecting terminals.

3. Intermittent buzzing of the buzzer when UPS input is normal.

Possible causes: Abnormal input voltage that exceeds the UPS' allowable input voltage range of power supply.

4. UPS works well when computer is in operation. After power failure, UPS works properly and the computer breaks down..

Possible cause: Poor earth connection as a result of much too high floating voltage of the zero line and earth wire.

5. All of panel indicator lamps are off.

Possible cause: Poor connection or malfunction of display control panel

# 5 . Packing, Transportation and Storage

## 5.1 Packing

UPS main unit is packed in packing-paper carton. The interior volume of the carton (L × W × H) is: 810mm×325mm×475mm

Pay attention to laying direction requirements for each part when packing.

The side faces of the carton are printed with such direction marks as keep dry, handle with care, this end up, pile number limit, as well as equipment model and other relevant information.

## 5.2 Transportation

Handle the goods with care; avoid violent impact. During transportation, place the cartons in strict accordance with the laying direction indicated on the packing carton to avoid damage to the devices.

## 5.3 Storage

The system equipment shall be stored in dry warehouse. Do not expose it to insolation or rain. Place it in the way as shown on the packing boxes. Store it where the ambient temperature is between - 25°C ~+55°C (except for battery). It is recommended to store the standard device and battery at places with temperature between 0~40°C and relative humidity between 20%~80%. No harmful gas, inflammable/detonable goods or corrosive chemicals shall be kept in the warehouse which shall also be free from strong mechanical vibration, impact and intense magnetic field affect. If not otherwise specified, the storage period of the equipment under the required conditions of this clause is 6 months. During long-term storage, charge the storage battery every 3 months.



**POWER SOLID**

[WWW.POWERSOLID.VN](http://WWW.POWERSOLID.VN)