



POWER SOLID

800W
LOW FREQUENCY INVERTER
PSi800W#12VM



USER MANUAL



WWW.POWERSOLID.VN

Table Of Contents

GENERAL PRECAUTIONS	1
PERSONNEL PRECAUTIONS	1
INTRODUCTION	2
PRODUCT OVERVIEW	2
INSTALLATION	3
Unpacking and inspection	3
Battery connection	4
OPERATION	6
LED indicators & audible alarms	6
LCD display	7
Display Select	8
LCD Setting	9
Operating mode description	11
Fault reference code	12
COMMUNICATION	13
TROUBLE SHOOTING	13
SPECIFICATIONS	14

GENERAL PRECAUTIONS

1. Before using it, read all instructions and markings:
(1) inverter (2) the batteries (3) this manual
2. CAUTION --To reduce risk of injury, charge only lead-acid rechargeable batteries. If customer use flooded batteries, they must maintain them. Other types of batteries may cause damage and injury.
3. Do not expose it to rain, snow or liquids of any type. It is designed for indoor.
4. Do not disassemble it. Take it to a qualified service center when service or repair is required.
5. To prevent the risk of electric shock, disconnect all wiring before attempting any maintenance or cleaning. Turning off the unit will not reduce this risk.
6. WARNING: Provide ventilation to outdoors from the battery compartment. The battery enclosure should be designed to prevent accumulation and concentration of hydrogen gas at the top of the compartment.
7. NEVER charge a frozen battery
8. Input/output AC wiring must be no less than 16 AWG gauge copper wire and rated for 75 °C or higher. Battery cable must be rated for 75°C or higher and should be no less than 6AWG gauge.
9. Be extra cautious when working with metal tools around batteries. Short-circuiting the batteries could cause an explosion.
10. Read the battery manufacturer's installation and maintenance instructions prior to operating.

PERSONNEL PRECAUTIONS

1. Have plenty of fresh water and soap nearby in case battery acid contacts skin, clothing or eyes.
2. Avoid touching eyes while working near batteries.
3. NEVER smoke or allow a spark or flame in vicinity of a battery.
4. Remove personal metal items such as rings, bracelets, necklaces, and watches when working with batteries. Batteries can provide heavy short-circuit current, enough to make metal melt and causes severe burn.
5. If a remote or automatic generator start system is used, disable the automatic starting circuit or disconnect the generator to prevent accident during servicing.

INSTALLATION

It is a cost effective, intelligent inverter with UPS function. The comprehensive LCD offers user-configurable and easy-accessible button adjustment such as battery charge current, battery charge Voltage, frequency, buzzer etc.

Features:

- Sine wave inverter
- Friendly user interface
- 3 steps charging algorithm
- MFD (multi-function display)
- Overload and short-circuit protection
- Battery reverse polarity protection
- Deep discharge protection
- Adjustable utility charging current
- Automatic voltage regulation
- Communication with PC

Horizontal

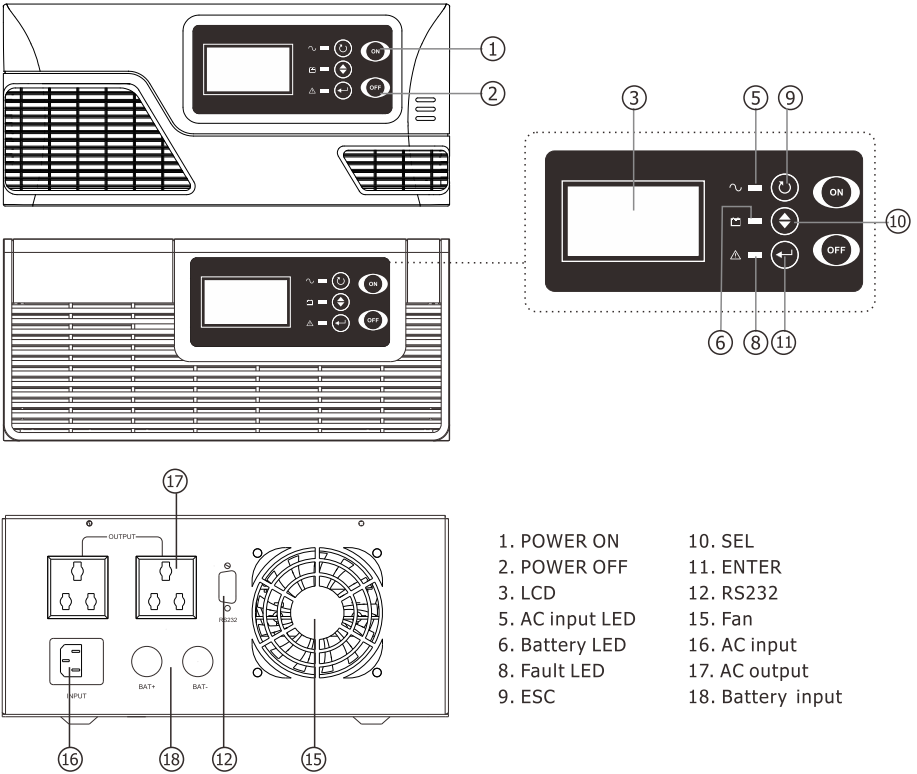

- | | |
|-----------------|-------------------|
| 1. POWER ON | 10. SEL |
| 2. POWER OFF | 11. ENTER |
| 3. LCD | 12. RS232 |
| 5. AC input LED | 15. Fan |
| 6. Battery LED | 16. AC input |
| 8. Fault LED | 17. AC output |
| 9. ESC | 18. Battery input |

INSTALLATION

Unpacking and inspection

Before installation, please inspect the unit. Be sure that nothing inside the package is damaged. You should have received the following items inside of package.

- The unit X 1
- Software CD X 1
- AC input cable X 1
- User manual X 1
- Communication cable X 1

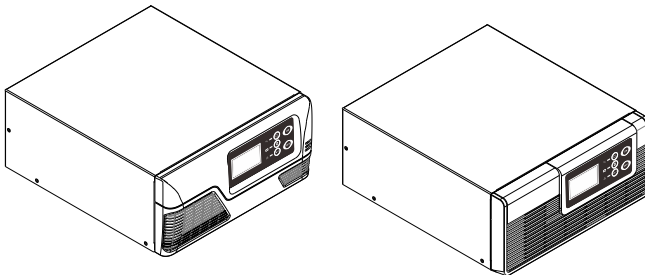

(horizontal)

Battery connection

Step1: Away the cover of external battery terminal.

Step2: Following battery polarity guide printed near the battery terminal.

RED cable to the positive terminal(+);

BLACK cable to the negative terminal (-);

WARNING! Please use the appropriate battery cable. Please refer to the following table.

Model	Battery voltage	Wire size
800W	12V	2*10AWG

Step3: Install a DC breaker in a positive line.

The rating of the DC breaker must be according to the inverter's battery current
150 A for 12V battery).

Note: you must keep the DC breaker off.

Step4: Connect battery cable to the external batteries.

Note: For the user operation safety. We strongly recommend that you should use tape to isolate the battery terminals before you start to operate the unit.

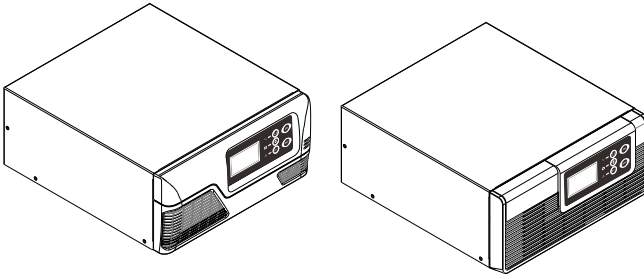

OPERATION



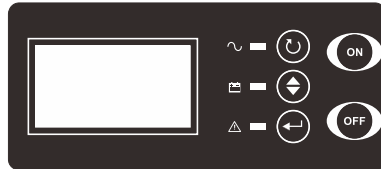

Press "ON" for 2 seconds to turn on the unit. The unit will work automatically in line mode or inverter mode according to input utility status. When "OFF" is pressed and hold for 2 seconds, the unit will be turned off. When machine is working, buzzer can be controlled by pressing "ON". The display panel, shown in below chart, is on the front panel of the inverter. It includes four front indicators, three function keys and a LCD display, indicating the operating status and input/output power information.



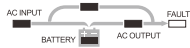
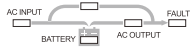

(horizontal)

LED Indicators & Audible Alarms

There are five LED indicators in the front panel of vertical machine.

LED Indicators	Messages
Backup Mode	
Line Mode	
Charger Mode	 All of LEDs is off.
Low battery voltage warning	Buzzing every 2 seconds and red LED blinking. Simultaneously, the icon,  , blinks
Overload warning	Buzzing every 2 seconds and red LED blinking. Simultaneously, the icon,  , blinks
Settings warning	Buzzing every 2 seconds and red LED blinking. Simultaneously, The icon,  , blinks
Fault mode	Buzzing continuously and red LED is on

There are three LED indicators in the front panel of horizontal machine.

	The Led is on except charger mode, when grid is connected.
	Battery Led is always on except charger mode.
	When any warn comes out, fault led will blink. In fault mode, fault led is always on.

LCD Display

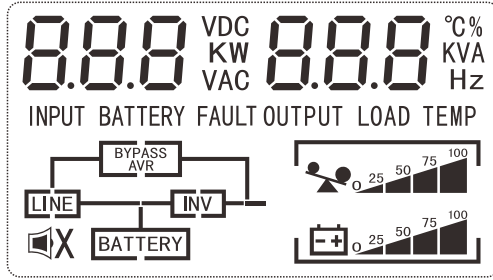

Display	Function			
Battery information in AC mode, it will present battery charging status				
Status	Battery voltage	LCD display		
Constant Current mode/Constant Voltage mode	0%~25%	All bars will blink in turns.		
	25%~50%	Bottom bar will be on and the other three bars will blink in turns.		
	50%~75%	Bottom two bars will be on and other bars will blink in turns.		
	75%~100%	Bottom three bars will be on and the top bar will blink.		
Floating mode. Batteries are fully charged		All bars will be on		
Battery information in battery mode, it will present battery capacity.				
Battery Voltage	LCD display			
0%~25%				
25%~50%				
50%~75%				
75%~100%				
Load information				
	Blinking load ICON Indicates overload.			
	Indicates the load level by 0-25%, 25-45%, 50-75% and 75-100%			
	0%~25%	25%~50%	50%~75%	75%~100%
Mode operation information	Refer to "Operating mode description"			
Buzzer information				
	Buzzer state is silence			
	Buzzer state is normal			
Selectable Information	Refer to "Display Select"			

Display Select

The LCD display information will be switched in turns by pressing "SEL" key. The selectable table information is as following table.

Selectable Information	LCD display
Input	<p>Input voltage=230 V, input frequency=50Hz</p> <p>230 VAC 50.0 Hz</p> <p>INPUT</p>
Output	<p>Output voltage=230 V, output frequency=50Hz</p> <p>230 VAC 50.0 Hz</p> <p>OUTPUT</p>
Load	<p>Power = 879W, percent= 88%</p> <p>879 W 88 %</p> <p>LOAD</p>
Load	<p>Power =312W, apparent power=445VA</p> <p>312 W 445 VA</p> <p>LOAD</p>
Temperature	<p>Temperature =30°C</p> <p>30 °C</p> <p>TEMP</p>

LCD Setting

After pressing and holding "ENTER" button for 2 seconds, the unit will enter setting mode. Press "ENTER" button to select setting programs. Press "SEL" button to change parameter. Press "ESC" button for 2 seconds to exit. All the parameters will take effect, after resetting machine.



Setting program information

Program	Description	Model: 12VDC	Model: 24VDC
03	Output voltage	220V 03 220 ^v	
		230V(default) 03 230 ^v	
04	Output frequency	50Hz (default) 04 50 ^{Hz}	
		60Hz 04 60 ^{Hz}	
07	Auto restart when overload occurs	Restart disable (default) 07 Lfd	Restart enable 07 LfE
13	Bulk current	5~30A (default value is 10A) 13 10 ^A	5~15A (default value is 10A) 13 10 ^A
17	Absorption charge voltage	13.8~14.5V (default value is 14.1V) 17 14.1 ^v	
18	Float charge voltage	13.5~14.5 V (default value is 13.6V) 18 13.6 ^v	

19	Shutdown voltage	10.0~12.0V (default value is 10.5V) 19 10.5 v
23	Backlight	OFF (default) 23 LOF
		ON 23 LON
24	Buzzer	ON (default) 24 bON
		OFF 24 bOF
29	AC charger	Enable grid charge (default) 29 UCE
		Disable grid charge 29 UCd
30	UPS function	ON(default) 30 ON
		OFF 30 OFF

If you want to reset all the parameters, pressing "SEL" button for 2 seconds will enter into reset settings dialog. Please select "DEF" through "SEL" button. Press "ESC" button for 2 seconds to exit and all parameters will be default state. Reset machine and all the parameters will take effect. If float charge voltage is higher than Absorption charge voltage, machine will alarm. Buzzing buzzer and blinking red LED. Simultaneously, The icon , **BATTERY** , blinks

Operating Mode Description

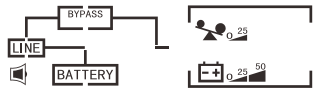
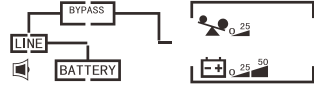
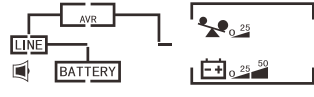
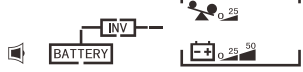
Operation mode	Description	LCD display
Fault mode	If any fault has happened, the machine will enter to the mode. And fault code is displayed on the LCD.	
Charger Mode	In this mode, the battery will be charged through grid power. When input power is abnormal, the machine will power off or switch to fault mode.	
Line Mode	Input power will provide energy to load directly. And it will charge the battery at the same time.	
	If voltage of input power is outside of section, [200v, 240v], AVR will work. When input power is abnormal, the machine will switch to battery mode.	
Battery Mode	The unit will get energy from battery and provide to load.	

Fault Reference Code

Fault Code	Fault Event	Icon on
02	Over Temperature	02
03	Battery voltage is too high	03
04	Battery voltage is too low	04
05	Output short circuited	05
06	Inverter output voltage is high	06
07	Over load	07
11	Main relay fault	11
41	Input voltage too low	41
42	Input voltage too high	42
43	Input frequency too low	43
44	Input frequency too high	44
45	AVR fault	45
51	Over current	51
58	Inverter output voltage is low	58

COMMUNICATION

Refer to User Guide of SolarPowerMonitor

TROUBLE SHOOTING

If machine enters into fault mode, please remove input power. And according to the table, deal with the following problems.

LED/Buzzer	LCD	Explanation / Possible cause	What to do
Buzzer beeps And red LED is off	Blink battery ICON	Battery voltage is too Low.	Charge the unit at least 8 hours.
	Blink load ICON	Over load.	Decrease your load.
Buzzer beeps continuously and red LED is on.	Fault code 02	Temperature of machine is too high.	Power off and waiting for minutes.
	Fault code 03	battery voltage is too high.	Check the battery specifications.
	Fault code 04	battery voltage is too low.	Check the battery specifications.
	Fault code 05	Output short circuited.	Remove your load and restart.
	Fault code 06	Inverter output voltage is high.	Return to repair center.
	Fault code 07	Over load.	Decrease your load.
	Fault code 11	Main relay fault.	Restart the machine. If it still can't work, please return to repair center.
	Fault code 41	Input voltage too low.	Check input power.
	Fault code 42	Input voltage too high.	
	Fault code 43	Input frequency too low.	
	Fault code 44	Input frequency too high.	
Fault code 45	AVR fault.	Restart the machine. If it still can't work, please return to repair center.	
Fault code 51	Output short circuited.	Check if wiring is connected well and remove abnormal load.	
Fault code 58	Output voltage is too low.	Decrease your load.	

SPECIFICATIONS

CAPACITY	PSI800W#12VM
INPUT	
Voltage Range	140~280VAC +/-5%
Frequency Range	50Hz+/-5Hz or 60Hz+/-5Hz
OUTPUT	
Voltage Regulation	Line mode
	200 VAC ~ 240 VAC
Output Frequency	60Hz or 50Hz
Transfer Time	8 ms (typical), 12 ms (max)
Waveform	sine wave
BATTERY	
Battery Voltage	12Vdc
Min battery voltage for power on	Shutdown voltage + 0.5V
Maximum Charge Current	800W
	25A
Over load	> 110%~125%Load Fault after 60S >125% ~150%Load Fault after 3s >150% Load Fault after 500ms
PHYSICAL	
Dimension (D*W*H) mm	420*280*225 (vertical) / 385*325*190 (Horizontal)
Net Weight (kg) (horizontal)	800W
	12.6
OTHER	
Storage temperature	-15°C to 55°C
Ambient temperature	0°C~40°C
Noise	≦ 60dB
Communication	USB



POWER SOLID

WWW.POWERSOLID.VN