

# **600KVA UPS ONLINE**

**PS-PMU600K50#50BC0KR**

## **USER MANUAL**

**WWW.POWERSOLID.VN**



All rights reserved.

The information in this document is subject to change without notice.

## **Publish statement**

Thank you for purchasing this series UPS.

This series UPS is an intelligent, three phase in Three phase out, high frequency online UPS designed by our R&D team who is with years of designing experiences on UPS. With excellent electrical performance, perfect intelligent monitoring and network functions, smart appearance, complying with EMC and safety standards, The UPS meets the world's advanced level.

Read this manual carefully before installation

This manual provides technical support to the operator of the equipment.

# Contents

<b>1. Safety</b> .....	2
1.1 Safety notes .....	2
1.2 Symbols used in this guide.....	2
<b>2. Main Features</b> .....	3
2.1 Summarization.....	3
2.2 Functions and Features .....	3
2.3 Model description .....	4
<b>3. Installation</b> .....	5
3.1 Unpack checking .....	5
3.2 The appearance of the product.....	5
3.3 UPS module appearance .....	25
3.4 Installation notes .....	25
3.5 External Protective Devices .....	26
3.6 Power Cables.....	27
3.7 Power cable connect.....	29
3.8 Battery connection .....	33
3.8.1 VRLA battery connection .....	33
3.8.2 Li battery connection.....	34
3.9 Online UPS Modules Replacement .....	35
3.10 UPS Multi - Module Installation.....	36
3.10.1 Cabinet installation .....	36
3.10.2 Parallel cable installation .....	37
3.11 LBS installation (optional).....	37
3.11.1 LCD setting .....	37
3.11.2 LBS cable installation .....	37
3.11.3 UPS installation.....	37
<b>4. Operation</b> .....	38
4.1 Operation Modes .....	38
4.2 Turn on/off UPS .....	40
4.2.1 Restart procedure.....	40
4.2.2 Test procedure .....	40
4.2.3 Cold start procedure.....	40
4.2.4 MAINTENANCE BYPASS .....	41
4.2.5 Shut down procedure.....	42
4.2.6 Startup procedure for parallel system .....	42
4.3 The Display.....	43
4.4 Display Messages/Troubleshooting.....	67
4.5 Options .....	71
<b>Appendix 1 Specifications</b> .....	73
<b>Appendix 2 Problems and Solution</b> .....	76
<b>Appendix 3 BMS communication port definition</b> .....	77
<b>Appendix 4 RS485 communication port definition</b> .....	78
<b>Appendix 5 BAT_T communication port definition</b> .....	78
<b>Appendix 6 LBS port definition</b> .....	79
<b>Appendix 7 REPO instruction</b> .....	79
<b>Appendix 8 Dry contact ports</b> .....	80
<b>Appendix 9 Backfeed Protection</b> .....	82

# 1. Safety

## Important safety instructions – Save these instructions

There exists dangerous voltage and high temperature inside the UPS. During the installation, operation and maintenance, please abide the local safety instructions and relative laws, otherwise it will result in personnel injury or equipment damage. Safety instructions in this manual act as a supplementary for the local safety instructions. Our company will not assume the liability that caused by disobeying safety instructions.

Contact the nearest hazardous waste disposal station when the products or components are discarded.

### 1.1 Safety notes

1. Even no connection with utility power, 220/230/240VAC voltage may still exist at UPS outlet!
2. For the sake of human being safety, please well earth the UPS before starting it.
3. Don't open or damage battery, for the liquid spilled from the battery is strongly poisonous and do harmful to body!
4. Please avoid short circuit between anode and cathode of battery, otherwise, it will cause spark or fire!
5. Don't disassemble the UPS cover, or there may be an electric shock!
6. Check if there exists high voltage before touching the battery
7. Working environment and storage way will affect the lifetime and reliability of the UPS. Avoid the UPS from working under following environment for long time
  - ◆ Area where the humidity and temperature is out of the specified range (temperature 0 to 40°C, relative humidity 5%-95%)
  - ◆ Direct sunlight or location nearby heat
  - ◆ Vibration Area with possibility to get the UPS crashed.
  - ◆ Area with erosive gas, flammable gas, excessive dust, etc
8. Keep ventilations in good conditions otherwise the components inside the UPS will be over-heated which may affect the life of the UPS.
9. There is no output switch in the Standard Version cabinet. During installation, an external output switch is required, and the auxiliary contact signal of the output switch is connected to the dry contact of the output switch of UPS, and the output dry contact signal of the switch is enabled on the display screen of ups.
10. **Do not connect the UPS output to regenerative load systems including photovoltaic system and speed drives. Failure to follow instruction can result in equipment damage!**

### 1.2 Symbols used in this guide



#### **WARNING!**

Risk of electric shock



#### **CAUTION!**

Read this information to avoid equipment damage

## 2. Main Features

### 2.1 Summarization

Our UPS is a kind of three-in- three -out high frequency online UPS, it provides three specifications: The 100~600kVA. The products are modularized and adopt the N+X redundancy. It can flexibly increase the number of the UPS modules according to the load capacity which is convenient for flexible allocation and gradually investment.

The UPS can solve most of the power supply problems, such as blackout, over-voltage, under-voltage, voltage sudden drop, oscillating of decreasing extent, high voltage pulse, voltage fluctuation, surge, inrush current, harmonic distortion (THD), noise interference, frequency fluctuation, etc..

This UPS can be applied to different applications from computer device, automatic equipment, communication system to industry equipment

### 2.2 Functions and Features

- ◆ Digital control

- ◆ 19-inch standard cabinet

1.2-meter and 2-meter high cabinets are provided according to the user's requirement.

- ◆ High power-density design

The height of the single module is 3U.

- ◆ N+X parallel redundancy

This series UPS adopts N+X parallel redundancy design, user can set different redundancy according to the importance of the load. While the redundancy modules are set more than two, the availability of UPS system will achieve 99.999%, which may satisfy the required reliability of the critical load connected. Through LCD display setting, you may configure the required quantity of the redundancy unit. When the load connected is over the number of the redundancy, the UPS will alert right away. The design of the MTBF (Meantime before Failure) is up to 250,000 hours.

This series can set the number of redundancy modules. When the load exceeds the redundancy setting, the UPS can still work normally and simultaneously send out corresponding warning as long as the load doesn't exceed the total capacity of modules.

- ◆ Parallel redundant control system.

- ◆ Optimizing distributed convergence for the cabinet.

- ◆ Centralized bypass.

- ◆ Support VRLA and Li battery.

- ◆ Common Battery.

- ◆ Automatic charge current adjustment according to battery capacity connected.

- ◆ 3-Stage intelligent charging.

- ◆ Touch-screen Super-large LCD display.

- ◆ Remote monitoring via SNMP.

- ◆ Optional Accessories available such as Isolation transformer, distribution Panel, SNMP Card, Relay Contact Board, etc...
- ◆ Equip with Maintenance Bypass Switch for easy maintenance purpose.
- ◆ Superior MTTR (Meantime to repair) & Short shutdown time in maintenance.
- ◆ Centralized monitoring module is also available.
- ◆ REPO function.

## 2.3 Model description

300 kVA, 350kVA, 400kVA, 450kVA and 500 kVA.

- ◆ 600kVA

The models provide 12 configurations: 50 kVA, 100 kVA, 150 kVA, 200 kVA, 250kVA, 300 kVA, 350kVA, 400kVA, 450kVA, 500 kVA, 550kVA and 600 kVA.

- \* **Standard configuration : cabinet only with maintenance bypass switch**
- \* **Full configuration : cabinet with mains, bypass, maintenance and output switch**

## 3. Installation

### 3.1 Unpack checking

1. Don't lean the UPS when moving it out from the packaging
2. Check the appearance to see if the UPS is damaged or not during the transportation, do not switch on the UPS if any damage found. Please contact the dealer right away.
3. Check the accessories according to the packing list and contact the dealer in case of missing parts.

**600kVA (Standard and Full configuration) , top and bottom entry**

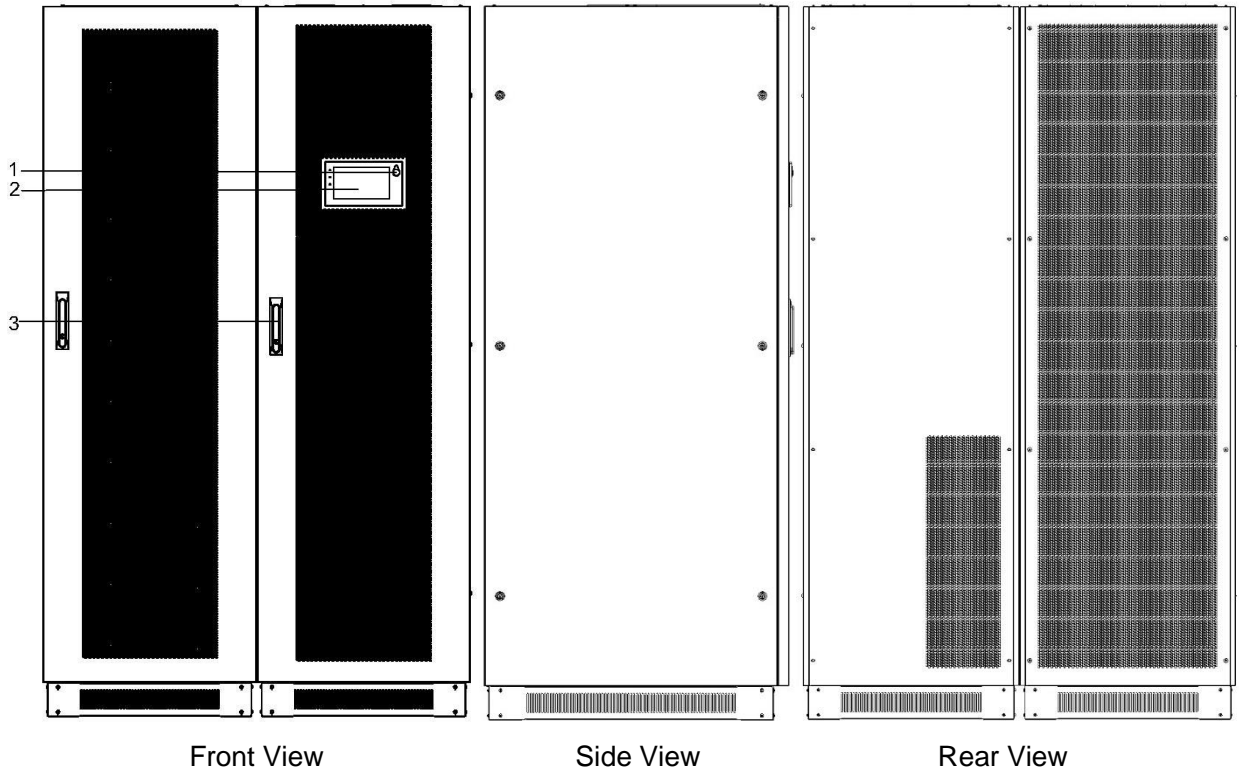

Mains-bypass common copper bar

**600kVA (Standard and Full configuration) , top and bottom entry**

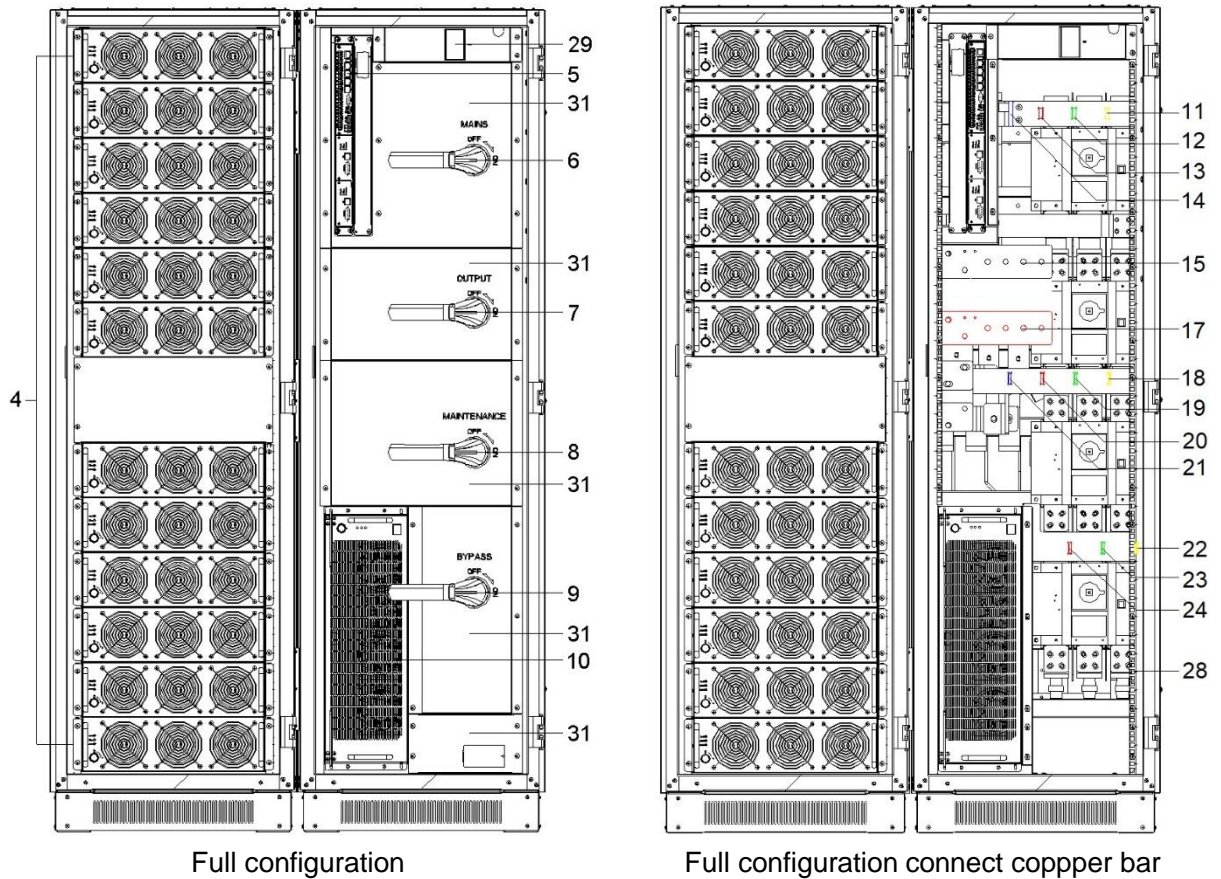



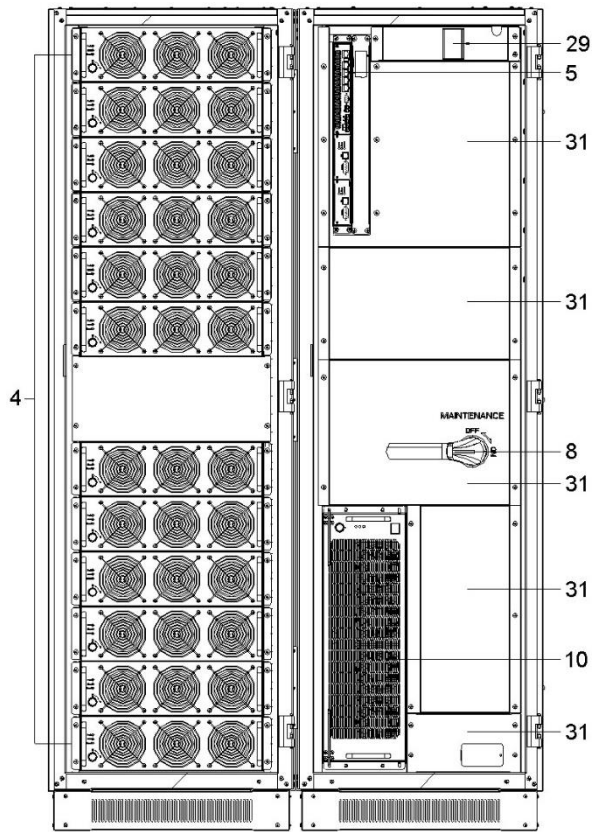

Standard configuration

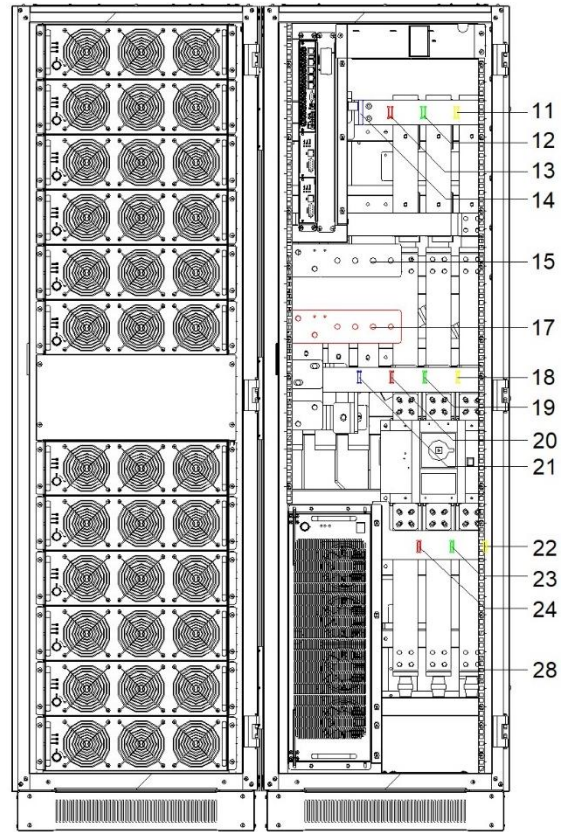

Standard configuration connect copper bar

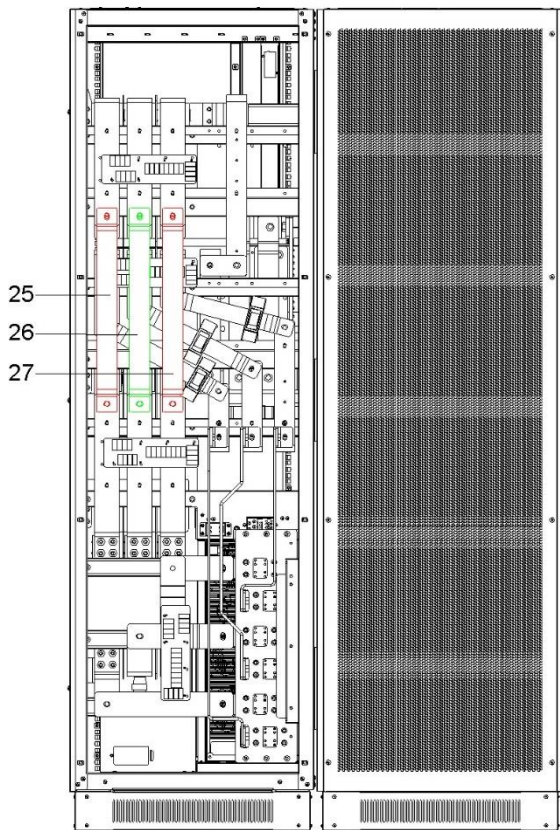

Mains-bypass common copper bar

- (1) EPO key

---

- (2) LCD panel : Display UPS data and status

---

- (3) Front door lock

---

- (4) Power module

---



- (5) Control unit
- (6) Mains switch
- (7) Output switch
- (8) Maintenance switch
- (9) Bypass switch
- (10) Bypass module
- (11) Mains-A input copper bar
- (12) Mains-B input copper bar
- (13) Mains-C input copper bar
- (14) Input neutral copper bar
- (15) Battery negative copper bar
- (17) Battery positive copper bar
- (18) Output-A input copper bar
- (19) Output-B input copper bar
- (20) Output-C input copper bar
- (21) Output neutral copper bar
- (22) Bypass-A input copper bar : Wiring must be used when mains-bypass separation
- (23) Bypass-B input copper bar : Wiring must be used when mains-bypass separation
- (24) Bypass-C input copper bar : Wiring must be used when mains-bypass separation
- (25) Phase A mains-bypass common input connect copper bar
- (26) Phase B mains-bypass common input connect copper bar
- (27) Phase C mains-bypass common input connect copper bar
- (28) Grounding copper bar
- (29) SPD
- (30) Maintenance bypass switch cover
- (31) Cabling cover

**Control unit**

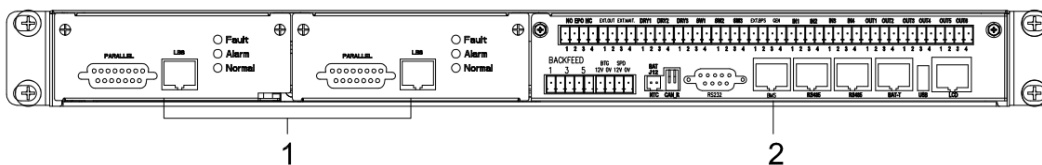

- (1) ECU1/2 : Centralized control unit
- (2) monitor unit

**ECU unit**

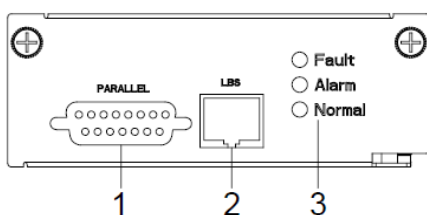

- (1) PARALLEL port
- (2) LBS port
- (3) LED

## Monitor unit

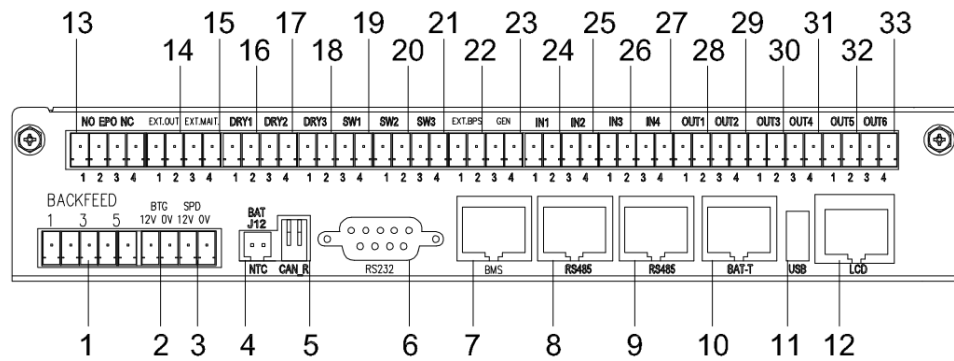

(1) BACKFEED: Bypass backfeed signal input port, PIN1\_common, PIN3\_NO, PIN5\_NC

(2) BTG: Battery grounding detect signal input port, 12V\_power supply, 0V\_GND

(3) SPD: SPD detect signal input port, 12V\_power supply, 0V\_GND

(4) BAT\_T: NTC temperature sensor port

(5) R-CAN: CAN communication resistor adjust

(6) RS232: RS232 communication port

(7) BMS: Communicate to Li battery BMS, include CAN and RS485 signal

(8) RS-485: RS485 communication port, parallel to 19

(9) RS-485: RS485 communication port, parallel to 18

(10) BAT\_T: battery temperature sensor port (RS485)

(11) USB: For software update and history download

(12) LCD: For LCD power supply and data communication

(13) EPO: NO-12V: Normally open port; NC-12V : normally close port;

(14) EXT.OUT: External output breaker auxiliary contact signal port, PIN1: 12Vdc, PIN2:GND

(15) EXT.MAINT: External maintenance breaker auxiliary contact signal port, PIN1: 12Vdc, PIN2:GND

(16) DRY1: Battery group 1 breaker driver signal output port PIN1: 24Vdc, PIN2:GND

(17) DRY2: Battery group 2 breaker driver signal output port PIN3: 24Vdc, PIN4:GND

(18) DRY3: Battery group 3 breaker driver signal output port PIN1: 24Vdc, PIN2:GND

(19) SW1: Battery group 1 breaker auxiliary contact signal port, PIN3: 12Vdc, PIN4:GND

(20) SW2: Battery group 2 breaker auxiliary contact signal port, PIN1: 12Vdc, PIN2:GND

(21) SW3: Battery group 3 breaker auxiliary contact signal port, PIN3: 12Vdc, PIN4:GND

(22) EXT.BPS: External bypass breaker auxiliary contact signal port, PIN1: 12Vdc, PIN2:GND

(23) GEN: Generator detect signal input port, PIN1: 12Vdc, PIN2:GND

(24) IN1: Optional input dry contacts 1, PIN1: 12Vdc, PIN2:GND

(25) IN2: Optional input dry contacts 2, PIN3: 12Vdc, PIN4:GND

(26) IN3: Optional input dry contacts 3, PIN1: 12Vdc, PIN2:GND

(27) IN4: Optional input dry contacts 4, PIN3: 12Vdc, PIN4:GND

(28) OUT1: Optional output dry contacts 1, PIN1: common, PIN2:NO

(29) OUT2: Optional output dry contacts 2, PIN3: common, PIN4:NO

(30) OUT3: Optional output dry contacts 3, PIN1: common, PIN2:NO

(31) OUT4: Optional output dry contacts 4, PIN3: common, PIN4:NO

(32) OUT5: Optional output dry contacts 5, PIN1: common, PIN2:NO

(33) OUT6: Optional output dry contacts 6, PIN3: common, PIN4:NO

### 3.3 UPS module appearance

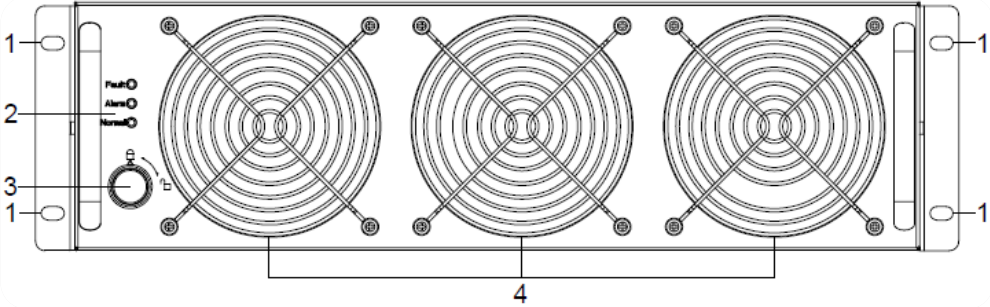

Front View

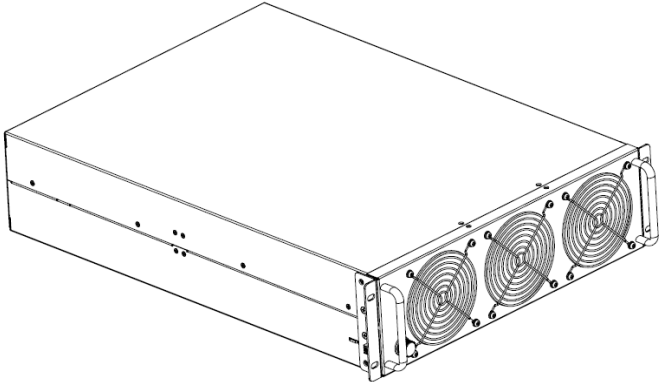

Side View

(1) Module fixed screw
(2) LED
(3) Module switch
(4) Fan

### 3.4 Installation notes

Note: Consider for the convenience of operation and maintenance, the space in front and back of the cabinet should be left at least 800mm and 800mm respectively when installing the cabinet.

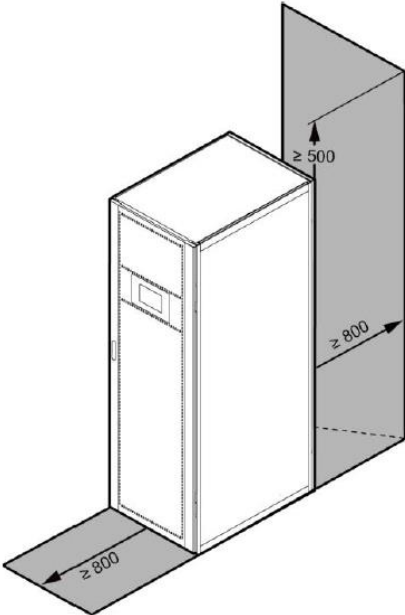

- ◆ Please place the UPS in a clean, stable environment, avoid the vibration, dust, humidity, flammable gas and liquid, corrosive. To avoid from high room temperature, a system of room extractor fans is recommended to be installed. Optional air filters are available if the UPS operates in a dusty environment.

- ◆ The environment temperature around UPS should keep in a range of 0°C~40°C. If the environment temperature exceeds 40°C, the rated load capacity should be reduced by 12% per 5°C. The max temperature can't be higher than 50°C.
- ◆ If the UPS is dismantled under low temperature, it might be in a condensing condition. The UPS can't be installed unless the internal and external of the equipment is fully dry. Otherwise, there will be in danger of electric shock.
- ◆ Batteries should be mounted in an environment where the temperature is within the required specs. Temperature is a major factor in determining battery life and capacity. In a normal installation, the battery temperature is maintained between 15°C and 25°C. Keep batteries away from heat sources or main air ventilation area, etc.



**WARNING!**

Typical battery performance data are quoted for an operating temperature between 20°C and 25°C. Operating it above this range will reduce the battery life while operation below this range will reduce the battery capacity.

- ◆ Should the equipment not be installed immediately it must be stored in a room so as to protect it against excessive humidity and or heat sources.



**CAUTION!**

An unused battery must be recharged every 6months temporarily connecting the UPS to a suitable AC supply mains and activating it for the time required for recharging the batteries.

- ◆ The highest altitude that UPS may work normally with full load is 1500 meters. The load capacity should be reduced when this UPS is installed in place whose altitude is higher than 1500 meters, shown as the following table:

(Load coefficient equals max load in high altitude place divided by nominal power of the UPS)

Altitude(m)	1500	2000	2500	3000	3500	4000	4500	5000
Load coefficient	100%	95%	90%	85%	80%	75%	70%	65%

- ◆ The UPS cooling is depending on fan, so it should be kept in good air ventilation area. There are many ventilation holes on the front and rear, so they should not be blocked by any exotic obstacles.

### 3.5 External Protective Devices

For safety reasons, it is necessary to install, external circuit breaker at the input A.C. supply and the battery. This chapter provides guidelines for qualified installers that must have the knowledge of local wiring practices for the equipment to be installed.

- ◆ **External Battery**

The UPS and its associated batteries are protected against the effect of over-current through a DC compatible thermo-magnetic circuit-breaker (or a set of fuses) located close to the battery.

- ◆ **UPS Output**

Any external distribution board used for load distribution shall be fitted with protective devices that may avoid the risk of UPS overloaded.

- ◆ **Over-current**

Protection device shall be installed at the distribution panel of the incoming main supply. It may identify the power cables current capacity as well as the overload capacity of the system.

### 3.6 Power Cables

- ◆ The cable design shall comply with the voltages and currents provided in this section, Kindly follow local wiring practices and take into consideration the environmental conditions (temperature and physical support media).

#### WARNING!



UPON STARTING, PLEASE ENSURE THAT YOU ARE AWARE OF THE LOCATION AND OPERATION OF THE EXTERNAL ISOLATORS WHICH ARE CONNECTED TO THE UPS INPUT/BYPASS SUPPLY OF THE MAINS DISTRIBUTION PANEL. CHECK TO SEE IF THESE SUPPLIES ARE ELECTRICALLY ISOLATED, AND POST ANY NECESSARY WARNING SIGNS TO PREVENT ANY INADVERTENT OPERATION

#### 3.6.1 Recommended cross-sectional areas for power cables

- ◆ For future expansion purpose, it is economical to install power cable according to the full rating capacity initially. The diameter of cable is shown below:

UPS cabinet (kVA)	Cable Dimension				
	AC Input (mm <sup>2</sup> )	BPS Input (mm <sup>2</sup> )	AC Output (mm <sup>2</sup> )	DC Input (mm <sup>2</sup> )	Grounding (mm <sup>2</sup> )
600	240*3	150*3	150*3	240*3	240

- ◆ When selecting, connecting, and routing power cables, follow local safety regulations and rules.
- ◆ If external conditions such as cable layout or ambient temperatures change, perform verification in accordance with the IEC-60364-5-52 or local regulations.
- ◆ If the rated voltage is 400 V, multiply the currents by 0.95. If the rated voltage is 415 V, multiply the currents by 0.92.
- ◆ If primary loads are non-linear loads, increase the cross-sectional areas of neutral wires 1.5–1.7 times.
- ◆ The nominal battery discharge current refers to the current of forty 12 V batteries at 480V in standard configuration.
- ◆ The maximum battery discharge current refers to the current when forty 12 V batteries in standard configuration, that is, two hundred and forty 2 V battery cells (1.67 V/cell), stop discharging.
- ◆ The battery cable specifications are selected based on 40 batteries by default and compatible with application scenarios with 30–50 batteries.
- ◆ When the mains input and bypass input share a power source, configure both types of input power cables as mains input power cables. The cables listed in Table are used only when the following requirements are met:
  - Routing mode: Routing the cables over the cable ladder or bracket in a single layer (IEC60364-5-52 middle E).
  - The ambient temperature is 30°C.
  - The AC voltage loss is less than 3%, and the DC voltage loss is less than 1%.
  - 90°C copper flexible cable.
  - The length of the AC power cables of a UPS is no longer than 30 m and DC power cables no longer than 50 m.



### 3.6.2 Power cable connector requirements

Model	Connector	Connection Mode	Bolt Type	Bolt Hole Diameter	Torque
600kVA	Mains input connector	Crimped OT terminals	M12	13.5mm	35N•m
	Bypass input connector	Crimped OT terminals	M12	13.5mm	35N•m
	Battery input connector	Crimped OT terminals	M12	13.5mm	35N•m
	Output connector	Crimped OT terminals	M12	13.5mm	35N•m
	Grounding connector	Crimped OT terminals	M12	13.5mm	35N•m

### 3.6.3 Recommended input front-end and output back-end circuit breakers

600kVA	Mains input circuit breaker	1250A 3P
	Bypass input circuit breaker	1000A 3P
	Output circuit breaker	1000A 3P
	Battery circuit breaker	2000A 3P



#### CAUTION!

Protective earth cable: Connect each cabinet to the main ground system. For Grounding connection, follow the shortest route possible.



#### WARNING!

FAILURE TO FOLLOW ADEQUATE EARTHING PROCEDURES MAY RESULT IN ELECTROMAGNETIC INTERFERENCE OR IN HAZARDS INVOLVING ELECTRIC SHOCK AND FIRE

### 3.7 Power cable connect

Before equipment has been installed, must confirm the input source type, common input or Split input, if the input source is dual input, must remove the copper bar that connected bypass and mains.

## 600kVA top and bottom entry

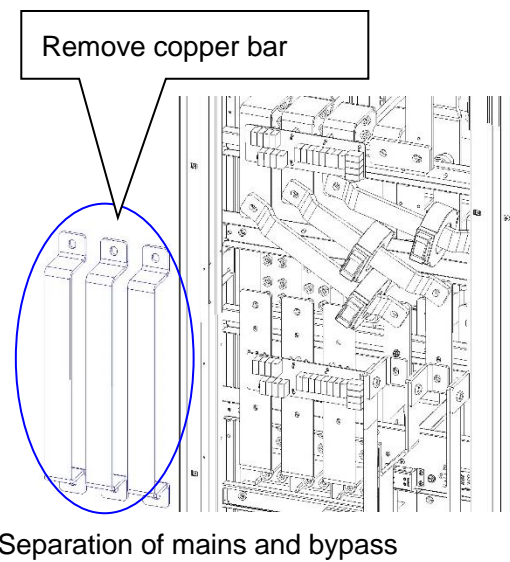
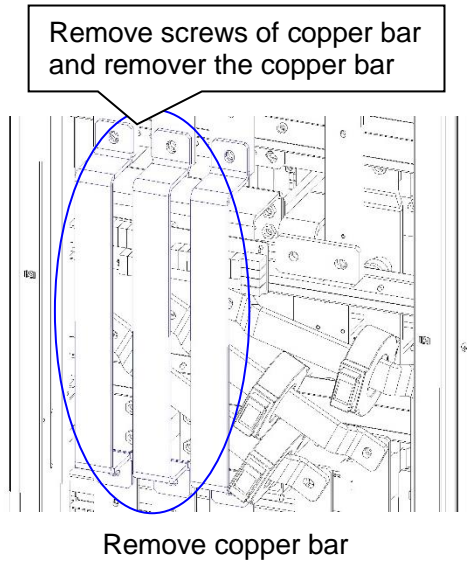

Choose appropriate power cable. (Refer to the table above) and pay attention to the diameter of the connection terminal of the cable that should be greater than or equal to that of the connection poles;

### Wiring

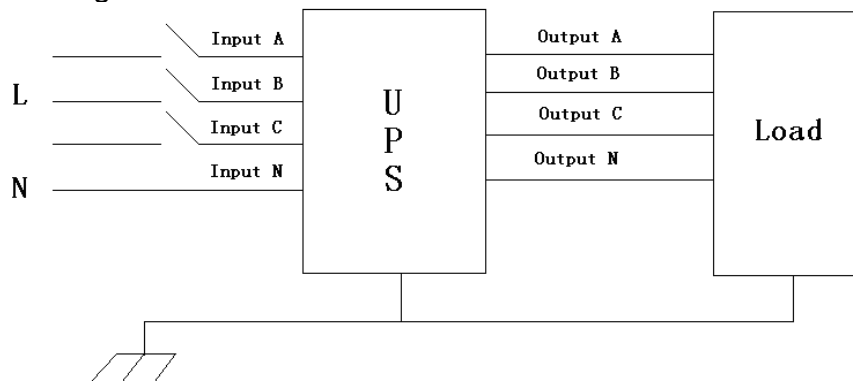

### WARNING!

If the load equipment is not ready to accept power on the arrival of the commissioning engineer then ensure that the system output cables are safely isolated at their ends

Connect the safety earth and any necessary bonding earth cables to the copper earth screw located on the floor of the equipment below the power connections. All cabinets in the UPS must be grounded properly.



### CAUTION!

The earthing and neutral bonding arrangement must be in accordance with local and national codes of practice.

## 3.8 Battery connection

### 3.8.1 VRLA battery connection

UPS adopts single battery pack architecture, with a total of 30 (optional 31/32/33/34/35/36/37/38/39/40/41/42/43/44/45/46/47/48/49/50) in series. Then connect the positive battery and the negative battery to the ups respectively. Users can select the capacity and quantity of batteries according to their own needs.

### 600kVA top and bottom entry

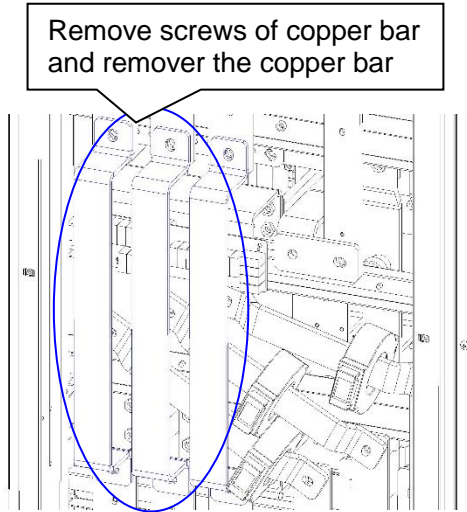

Remove copper bar

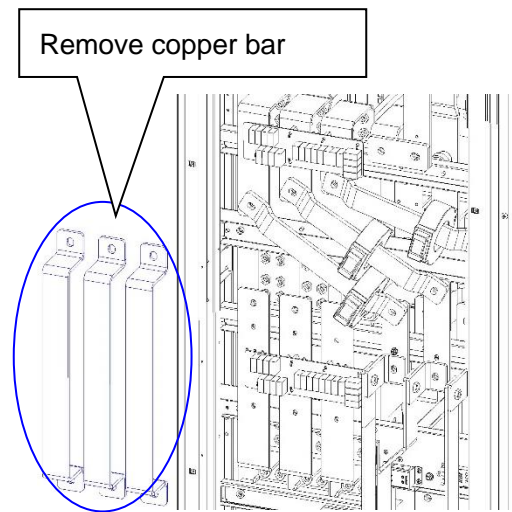

Separation of mains and bypass

Choose appropriate power cable. (Refer to the table above) and pay attention to the diameter of the connection terminal of the cable that should be greater than or equal to that of the connection poles;

#### Wiring

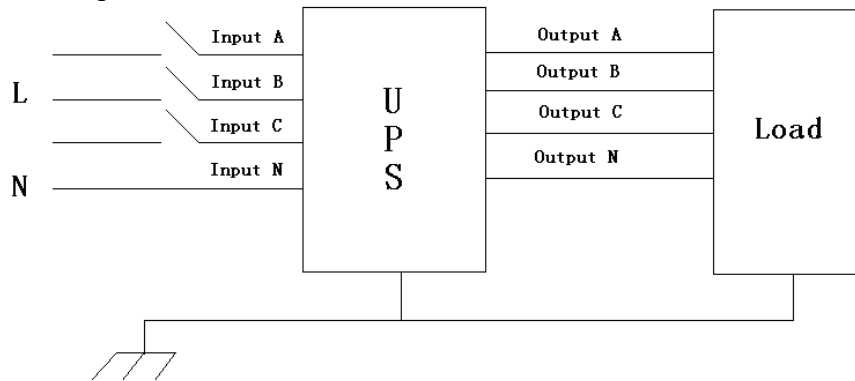

#### WARNING!

If the load equipment is not ready to accept power on the arrival of the commissioning engineer then ensure that the system output cables are safely isolated at their ends

Connect the safety earth and any necessary bonding earth cables to the copper earth screw located on the floor of the equipment below the power connections. All cabinets in the UPS must be grounded properly.



#### CAUTION!

The earthing and neutral bonding arrangement must be in accordance with local and national codes of practice.

## 3.8 Battery connection

### 3.8.1 VRLA battery connection

UPS adopts single battery pack architecture, with a total of 30 (optional 31/32/33/34/35/36/37/38/39/40/41/42/43/44/45/46/47/48/49/50) in series. Then connect the positive battery and the negative battery to the ups respectively. Users can select the capacity and quantity of batteries according to their own needs.

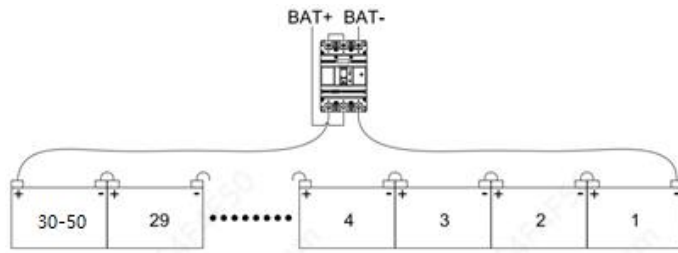

Note:

The BAT+ of UPS connecting pole is connected to the anode of battery 30 (31/32/33/34/35/36/37/38/39/40/41/42/43/44/45/46/47/48/49/50), and the BAT- is connected to the cathode of battery 1.

Factory setting of the long-run unit is battery quantity---30pcs, battery capacity---12V 100AH. When connecting 31/32/33/34/35/36/37/38/39/40/41/42/43/44/45/46/47/48/49/50 batteries, please re-set desired battery quantity and its capacity after UPS starts at AC mode. Charger current could be adjusted automatically according to battery capacity selected. All related settings can be done through LCD panel or monitoring software.



**CAUTION!**

Ensure correct polarity battery string series connection. i.e. inter-tier and inter block connections are from (+) to (-) terminals.

Don't mix batteries with different capacity or different brands, or even mix up new and old batteries, either.



**WARNING!**

Ensure correct polarity of string end connections to the Battery Circuit Breaker and from the Battery Circuit Breaker to the UPS terminals i.e. (+) to (+) / (-) to (-) but disconnect one or more battery cell links in each tier. Do not reconnect these links and do not close the battery circuit breaker unless authorized by the commissioning engineer.

**3.8.2 Li battery connection**

UPS adopts single battery pack architecture, the voltage of battery is 512Vdc. Then connect the positive battery and the negative battery to the ups respectively. Connect the power on dry contactor port L/N of Li battery cabinet to UPS LIB POWER ON port or to line input of UPS. Change the battery type to Li battery on UPS LCD.

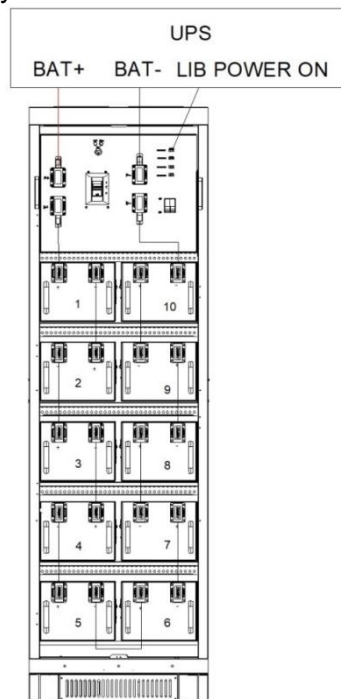

Note:

The BAT+ of UPS connecting pole is connected to the P+ of Li battery, and the BAT- is connected to the P- of Li battery. LIB power on L-N connector to UPS input L-N or power source L-N.

The capacity of battery is define by the Li battery.

### WARNING!



Ensure correct polarity of string end connections to the Battery Circuit Breaker and from the Battery Circuit Breaker to the UPS terminals i.e. (+) to (+) / (-) to (-) but disconnect one or more battery cell links in each tier. Do not reconnect these links and do not close the battery circuit breaker unless authorized by the commissioning engineer.

## 3.9 Online UPS Modules Replacement

For the UPS, modules must be inserted to make a complete UPS system.

The replacement of UPS module is very simple and can be operated online. The control system of the UPS can detect the inserted or removed module(s) automatically. The user may operate easily by following the steps mentioned below.

◆ **NOTE: The UPS module is rather heavy, please move it by two people!**

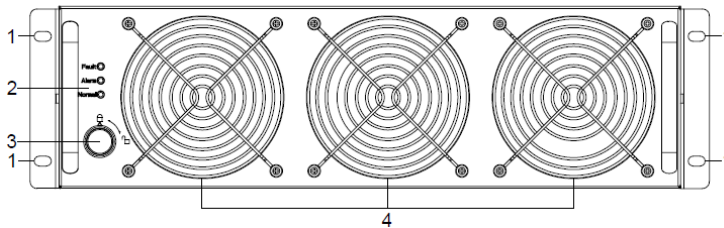

### ◆ Insert module

- (1) Remove decorated panel;
- (2) Put the UPS module in the cabinet module slot. Push the module along the slot into the cabinet until the module is inserted properly, then the indicator will flash.
- (3) Fix the module with screws (1) at the positioning screw holes;
- (4) Switch on the module\_ON switch (3) at the left of the module panel, then the red indicator (2) will off.
- (5) After the modules start up, the system will detect the modules inserted automatically and parallel up the modules into whole system.

### ◆ Remove UPS module

Switch off the module\_ON switch (3) at the left of the module panel, then the red indicator (2) will light and green indicator flash. Remove the screws (1) of the module and remove the module from the cabinet.

### WARNING!



- (1) Before start the module, the module\_ON switch must on the "ON" status and the red indicator must flash or off.
- (2) Before remove the module, the module\_ON switch must on the "OFF" status and the red indicator must light.
- (3) When insert the module under battery mode, please press "Cold start" button at bypass module panel until the modules starts.



### 3.10 UPS Multi—Module Installation

The basic installation procedure of a parallel system comprising of two or more UPS modules is the same as that of single module system. The following sections introduce the installation procedures specified to the parallel system.

#### 3.10.1 Cabinet installation

Connect all the UPS needed to be put into parallel system as below picture.

##### Common input:

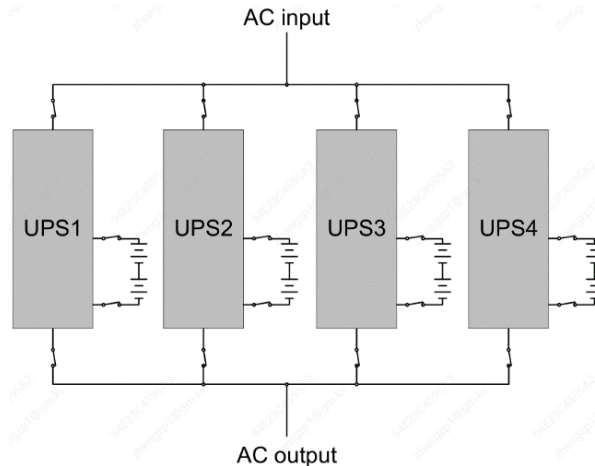

##### Dual input:

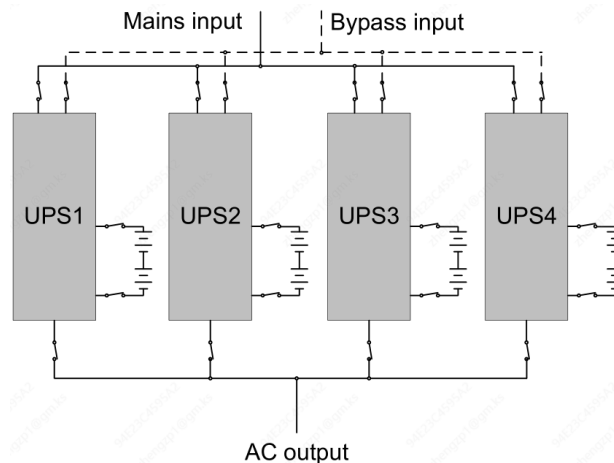

Make sure each UPS input switch is in “off” position and there is no any output from each UPS connected. Battery groups can be connected separately or in parallel, which means the system itself provides both separate battery and common battery.



#### CAUTION!

A group of parallel systems is equivalent to a large capacity UPS, but it has higher reliability. In order to ensure that all UPS machines are current sharing, and comply with the relevant wiring rules, the following requirements should be met:

- ◆ All UPS must be the same rated and connected to the same way bypass power supply.
- ◆ Bypass and the mains input power must be received with the same neutral.
- ◆ The output of all UPS machines must be connected to a common output bus.
- ◆ All bypass input cables and UPS output cables should be of the same length and specification, which is to make the machine operate in the bypass mode and compare the current sharing.

### 3.10.2 Parallel cable installation

Shielded and double insulated control cables, available 10 meters long as a standard, must be interconnected in a ring configuration between UPS modules as shown below. The parallel control board is mounted on each UPS module. The ring configuration ensures high reliability of the control.

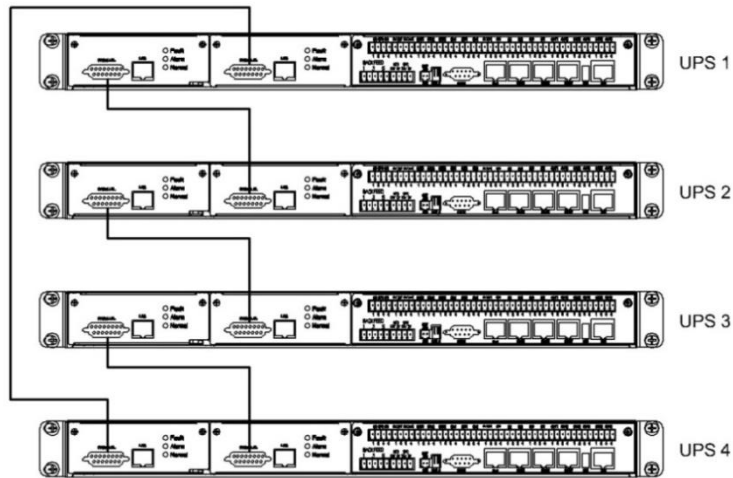

### 3.11 LBS installation (optional)

LBS system contains LCD set, cable connect and STS device.

#### 3.11.1 LCD setting

Set every UPS of the systems to be LBS Master or LBS Slave. For instance if the UPS belongs to LBS master system, its LBS setting must be set to Master.

#### 3.11.2 LBS cable installation

The two ports of one mesh wire should be plug into RJ45 interface of any one UPS of both master and slave system.

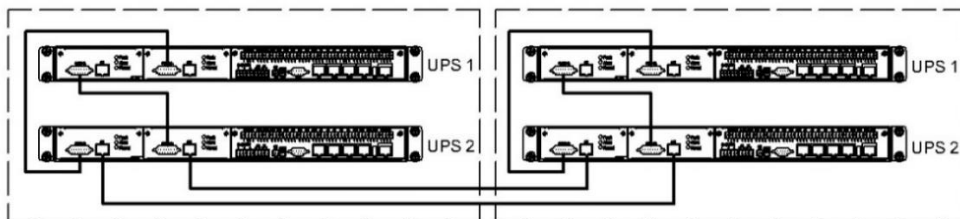

#### 3.11.3 UPS installation

The whole systems are showed below.

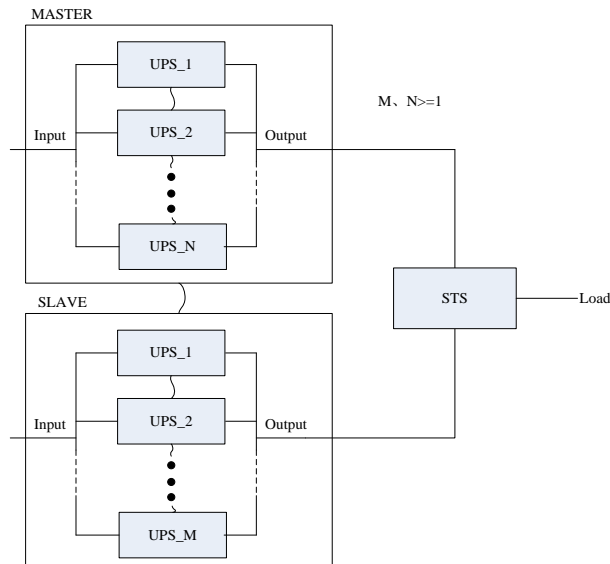

## 4. Operation

### 4.1 Operation Modes

The UPS is a double-conversion on-line UPS that may operate in the following alternative modes:

#### ◆ Normal mode

The rectifier/charger derives power from the AC Mains and supplies DC power to the inverter while floating and boosting charge the battery simultaneously. Then, the inverter converts the DC power to AC and supplies to the load.

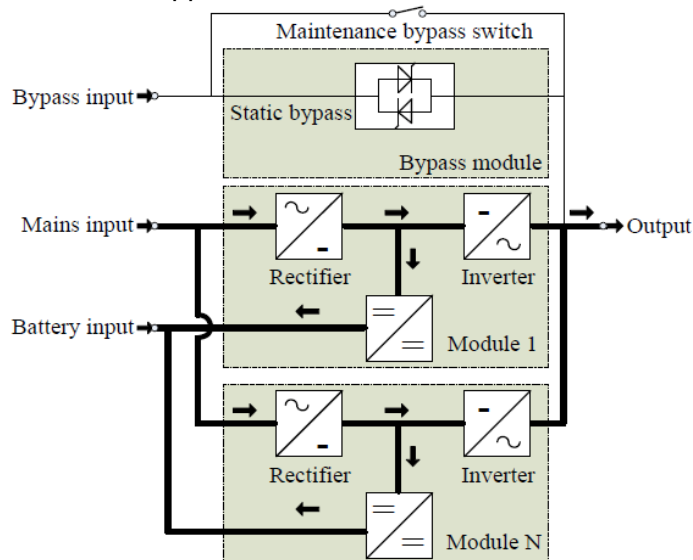

#### ◆ Battery mode (Stored Energy Mode)

If the AC mains input power fails, the inverter, which obtains power from the battery, supplies the critical AC load. There is no power interruption to the critical load. The UPS will automatically return to Normal Mode when AC recovers.

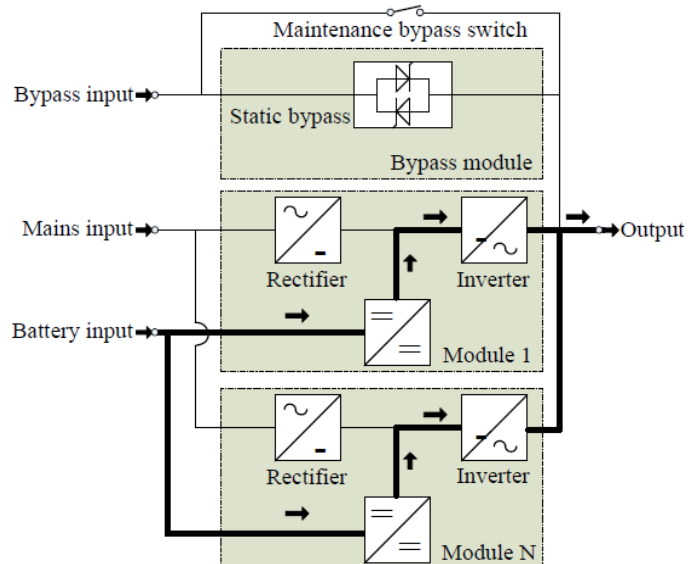

#### ◆ Bypass mode

If the inverter is out of order, or if overload occurs, the static transfer switch will be activated to transfer the load from the inverter supply to bypass supply without interruption to the critical load. In the event that the inverter output is not synchronized with the bypass AC source, the static switch will perform a transfer of the load from the inverter to the bypass with power interruption to the critical AC load. This is to avoid paralleling of unsynchronized AC sources. This interruption is programmable but typically set to be less than an electrical cycle e.g. less than 15ms (50Hz) or less than 13.33ms (60Hz).

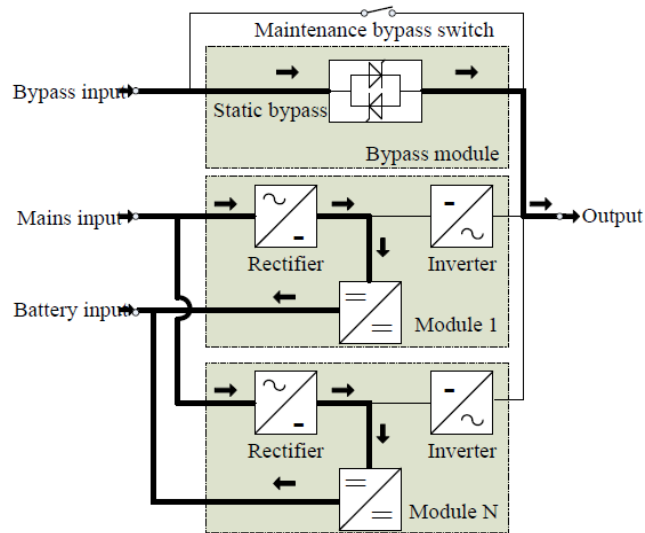

◆ **ECO Mode**

When the UPS is at AC Mode and the requirement to the load is not critical, the UPS can be set at ECO mode in order to increase the efficiency of the power supplied. At ECO mode, the UPS works at Line-interactive mode, so the UPS will transfer to bypass supply. When the AC is out of set window, the UPS will transfer from bypass to Inverter and supplies power from the battery, and then the LCD shows all related information on the screen.

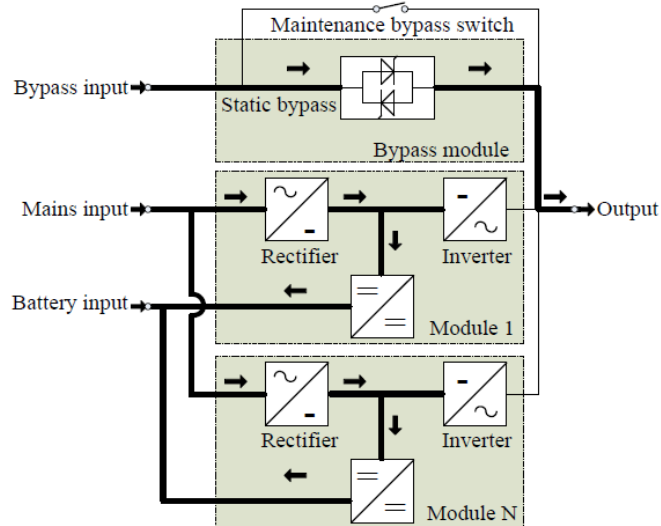

◆ **Maintenance mode (Manual Bypass)**

A manual bypass switch is available to ensure continuity of supply to the critical load when the UPS is out of order or in repair. This manual bypass switch is fitted for all UPS modules and bears for equivalent rated load.

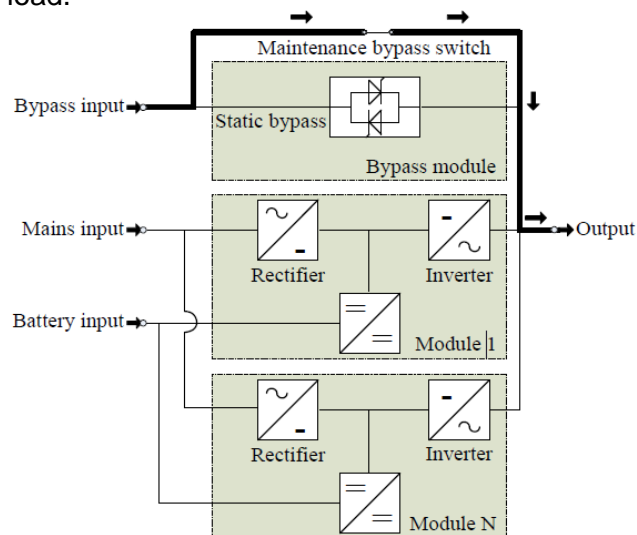

## 4.2 Turn on/off UPS

### 4.2.1 Restart procedure



#### CAUTION!

MAKE SURE GROUNDING IS PROPERLY DONE!

- ◆ Set the Battery Switch to the “ON” position according to the user’s manual.
- ◆ Open door of the UPS to access to the main power switches. During this procedure the output terminals will become alive.



#### CAUTION!

Check to see if the load is safely connected with the output of the UPS. If the load is not ready to receive power from the UPS, make sure that it is safely isolated from the UPS output terminals

- ◆ Turn ON the bypass and input switches of the UPS, make sure that “Bypass module” insert the cabinet and fix with screws and the module\_in switch at the on status

When AC MAINS input voltage within the range, and the rectifiers of the UPS will be started up in 30 seconds, then the inverter is started completely. When the output switch is “ON”, the inverter LED lights up.

- ◆ Switch ON output switch

If the rectifier of the module does not start-up, the green LED will flash, bypass module green LED will light on, the power module green LED will flash. when UPS turn to inverter mode power module and display panel green LED will light on.

No matter the UPS is operated normally or not, the LCD display will indicate current status.

### 4.2.2 Test procedure



#### CAUTION!

The UPS is operating normally.

It may take 60 seconds to boost up the system and perform self-test completely.

- ◆ Switch off the MAINS to simulate utility failure, the rectifier will turn off and the battery should feed the inverter without interruption.
- ◆ Switch on the MAINS to simulate utility recovery, the rectifier will restart automatically after 20 seconds and the inverter will supply to the load. It is suggested to use Dummy loads for testing. The UPS can be loaded up to its maximum capacity during load test.

### 4.2.3 Cold start procedure



#### CAUTION!

Follow these procedures when the input AC Utility Failure, but battery is normal

- ◆ Switch on the battery switch.  
The battery will feed the Auxiliary power board.
- ◆ Switch on the Output switch
- ◆ Trigger the cold start button of the bypass module.

When battery normal, rectifier starts operation, 30s later, inverter starts and operates and the green LED will light on.



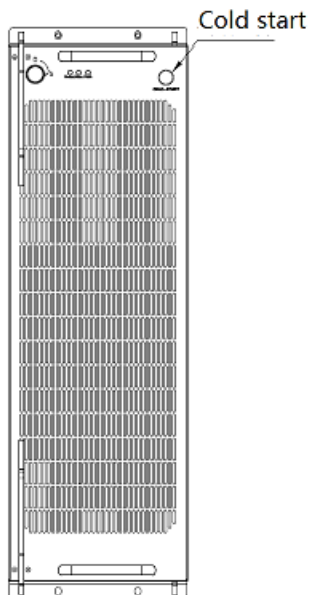

### **CAUTION!**

Wait for approximately 30 seconds before you press the black start key

#### **4.2.4 MAINTENANCE BYPASS**

To supply the load via Mains, you may simply active the internal mechanical bypass switch.



### **CAUTION!**

The load is not protected by the UPS when the internal mechanical bypass system is active and the power is not conditioned.

#### **Switch to mechanical bypass**



### **CAUTION!**

If the UPS is running normally and can be controlled through the display, carry out steps 1 to 5; otherwise, jump to Step 4.

- ◆ Turn off the inverter on the LCD (1.2m cabinet: remove the maintenance cover), then the UPS turns to bypass mode automatically.
- ◆ Switch on the maintenance switch;
- ◆ Switch OFF the battery breaker;
- ◆ Switch OFF the mains switch;
- ◆ Switch OFF the output switch;

At this time the bypass source will supply to the load through the maintenance switch.

#### **Switch to normal operation (from mechanical bypass)**



### **CAUTION!**

Never attempt to switch the UPS back to normal operation until you have verified that there are no internal UPS faults

- ◆ Open the front and rear doors of the UPS to be easily access to the main power switches

- ◆ Switch ON the output switch;
- ◆ Switch ON the bypass and mains switch;
- ◆ Switch ON the battery breaker;

The UPS powers from the static bypass instead of the maintenance bypass.

- ◆ Switch OFF the maintenance bypass switch, then the output is supplied by the bypass of the modules.
- ◆ Put on the maintenance switch cover (1.2m cabinet).

The rectifier will operate normally after 30 seconds. If the inverter works normally, the system will be transferred from bypass mode to normal mode.

#### 4.2.5 Shut down procedure



##### **CAUTION!**

This procedure should be followed to completely shut down the UPS and the LOAD. After all power switches, isolators and circuit breakers are opened, there will be no output.

- ◆ Press the INVERTER OFF key on the LCD display;
- ◆ Switch OFF the BATTERY breaker;
- ◆ Open the UPS door to easily access to the main power switch;
- ◆ Switch OFF the input switch.
- ◆ Switch OFF the OUTPUT switch. The UPS shuts down;



##### **WARNING!**

Wait for about 5 minutes for the internal D.C. bus bar capacitors to be completely discharged.

#### 4.2.6 Startup procedure for parallel system

- ◆ Connect parallel cable, input/output cable, and battery cable well; modify the parallel board jumpers correctly.
- ◆ Measure the positive and negative battery pack voltage. Battery switch is opened temporarily.
- ◆ Switch ON the output switch at the front door.
- ◆ According to the startup procedure for single unit, set the operation mode of each UPS: single mode is changed to parallel mode; set the parallel number for each UPS; up to 4 units can be parallel; set the ID of each cabinet, the ID of each unit must be different.
- ◆ Switch ON the input switch. Close the external input switch and start from mains.
- ◆ After start from mains, check the LCD interface of each UPS to see if the ID, VA is the same with the actual values.
- ◆ Switch ON the external battery switch of each UPS. Check if the charging current displayed in LCD is normal.



##### **Note!**

**The UPS cannot be parallel until each single unit is normal.**

### 4.3 The Display

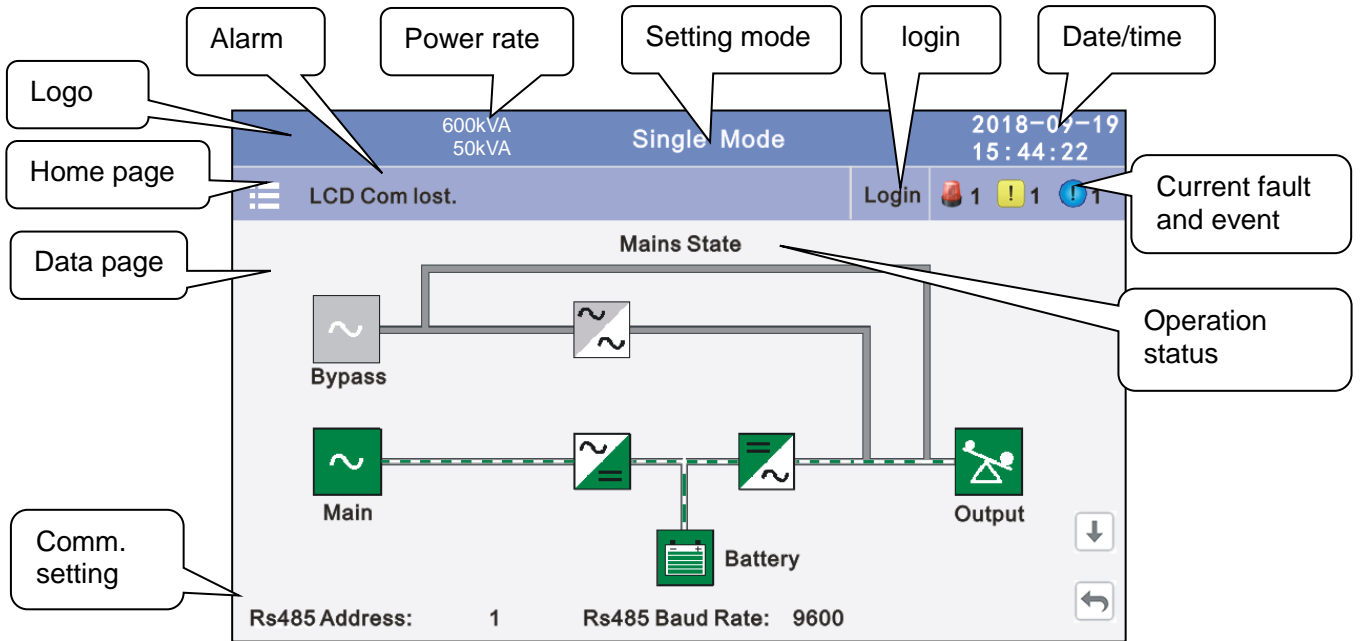

**4.3.1 Datas:** Displays the flow state of UPS work, and quickly enters real-time data by clicking on the block.

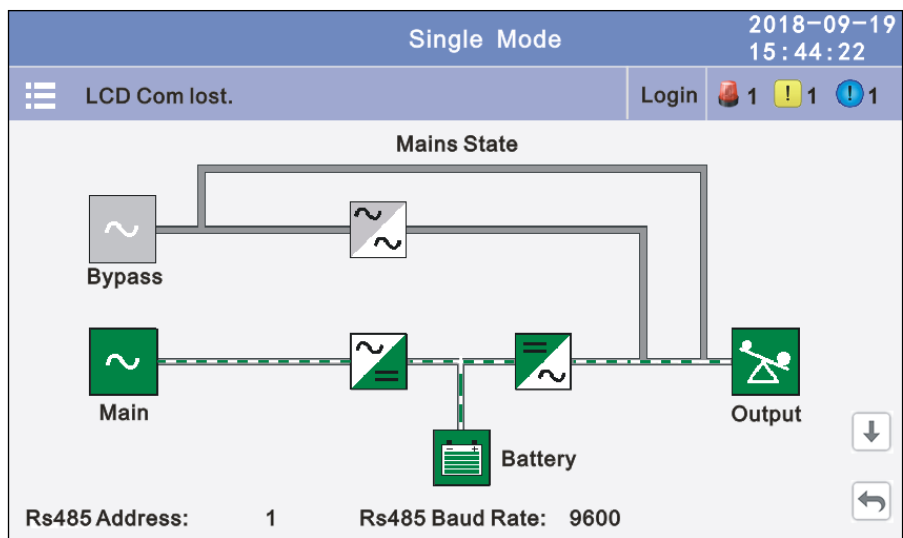

Input Voltage(V)		On-line			Output Freq(Hz)	
A	220.0V	Battery			50.0Hz	
B	220.0V	100%	999M			
C	220.0V	Float charging			Output Voltage(V)	
Input current(A)		Actv Power(kW):			A 220.0V	
A	10.0A	10.0	10.0	10.0	B 220.0V	
B	10.0A	Apparent Power(kVA):			C 220.0V	
C	10.0A	10.0	10.0	10.0	Output current(A)	
		Load Rate(%):			A 10.0A	
		50%	50%	50%	B 10.0A	
					C 10.0A	

**4.3.2 Status:** View the voltage and current of the main, bypass, output, battery (can also be entered through by real-time data block), view the status of the switches, dry contacts and module, through clicking on the block, enter the corresponding data window.

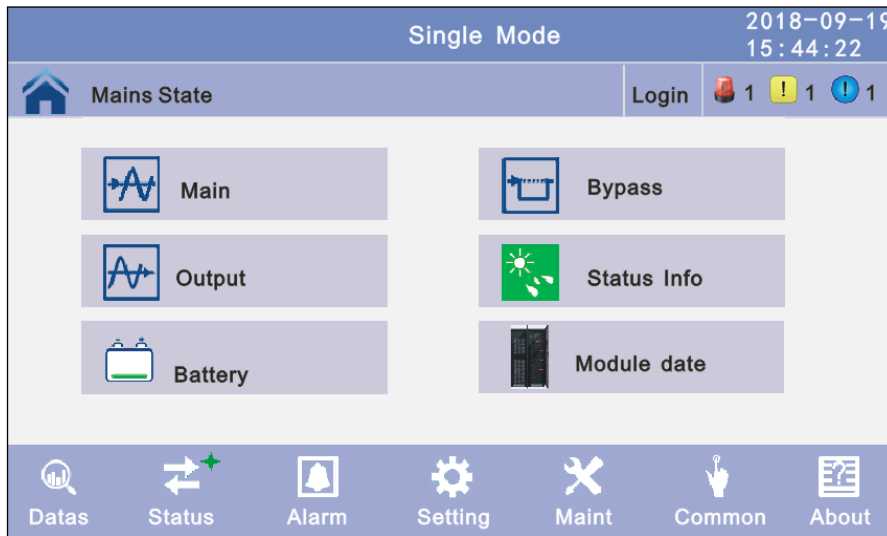

**4.3.2.1 Main:** Click the main block to enter the main data display window, click return to return to the previous window, click home page to return to the main page.

	A	B	C
Phase Volt (V) :	220.0	220.0	220.0
Line Volt (V) :	380.0	380.0	380.0
Phase Freq (Hz) :	50.0	50.0	50.0
Phase Current (A) :	5.5	5.0	6.0
Input Factor:	0.932	0.931	0.921

**4.3.2.2 Bypass:** Click the bypass block to enter the bypass data display window, click return to return to the previous window, click home page to return to the main page.

	A	B	C
Phase Volt (V) :	220.0	220.0	220.0
Line Volt (V) :	380.0	380.0	380.0
Phase Freq (Hz) :	50.0	50.0	50.0

**4.3.2.3 Output:** Click the output block to enter the output data display window, click return to return to the previous window, click home page to return to the main page.

Single Mode 2018-09-19 15:44:22

Mains State Login 1 1 1

	A	B	C
Phase Volt (V) :	220.0	220.0	220.0
Line Volt (V) :	380.0	380.0	380.0
Phase Freq (Hz) :	50.0	50.0	50.0
Phase Current (A) :	5.5	5.0	6.0

Output

Single Mode 2018-09-19 15:44:22

Mains State Login 1 1 1

	A	B	C
Apparent Power (kVA) :	1.0	1.0	1.0
Actv Power (kW) :	1.0	1.0	1.0
Load Rate (%) :	1.0%	1.0%	1.0%
Load Peak Ratio:	1.5	1.0	1.0

Output

**4.3.2.4 Battery:** Click the battery block to enter the battery data display window, click return to return to the previous window, click home page to return to the main page.

Single Mode 2018-09-19 15:44:22

Mains State Login 1 1 1

Voltage (V) :	512
Current (A) :	0
Batt Status:	Standby
Temp (°C) :	0.0

Battery

**4.3.2.5 Status info:** Click the status info block to enter the status data display window, click return to return to the previous window, click home page to return to the main page.

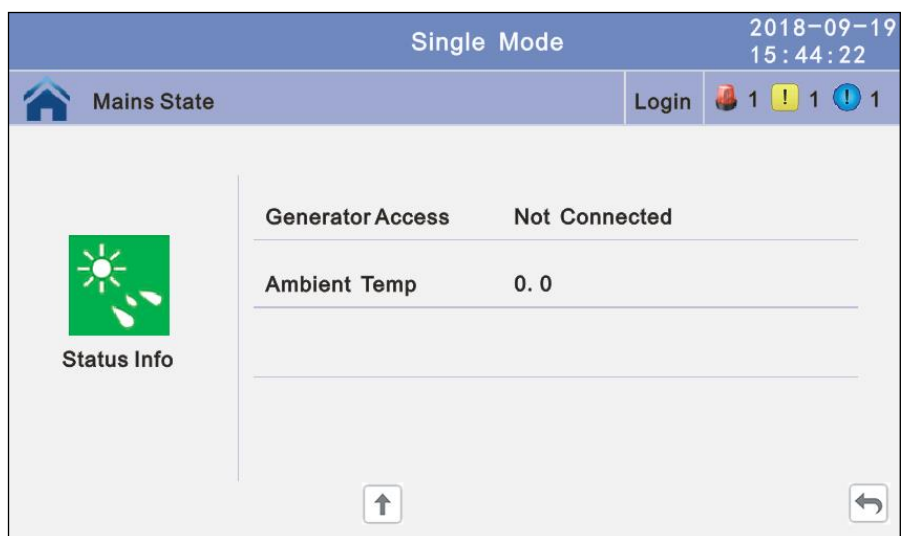
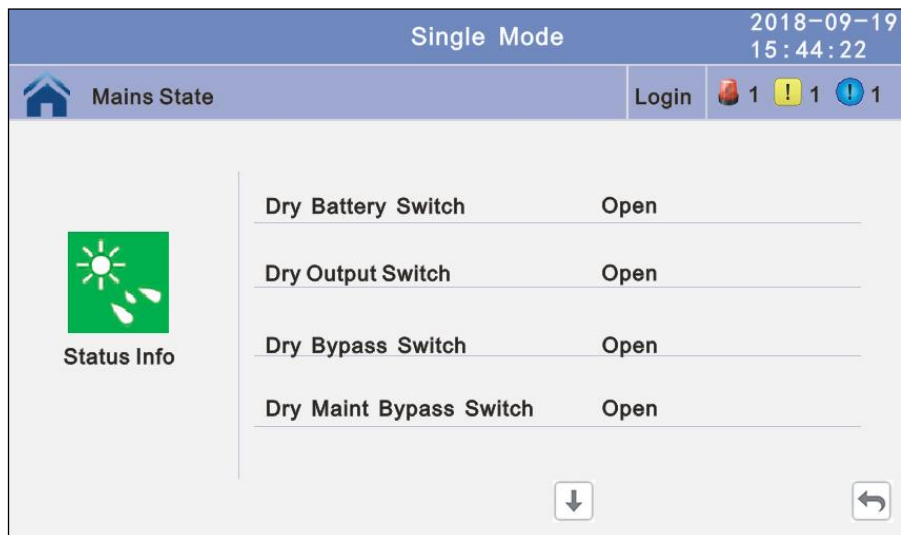
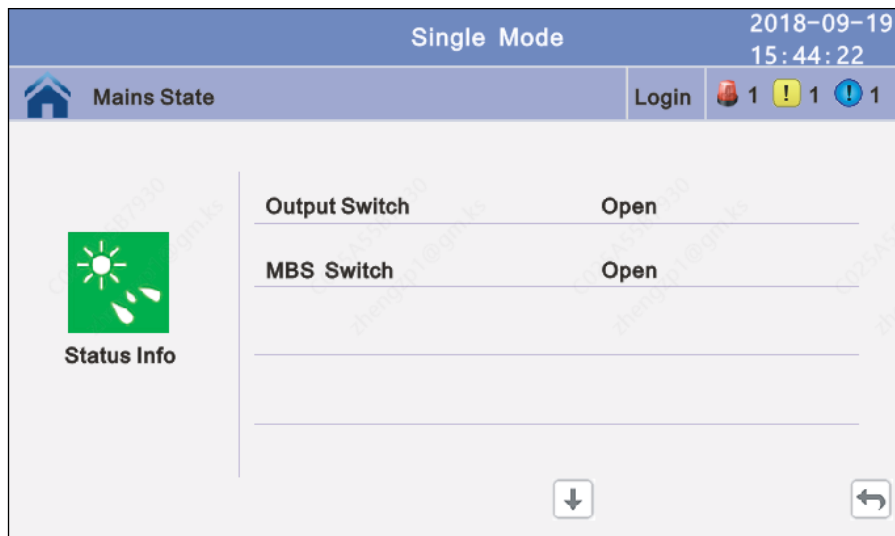



**4.3.2.6 Module:** Click the module block to enter the module data display window, click return to return to the previous window, click home page to return to the main page.

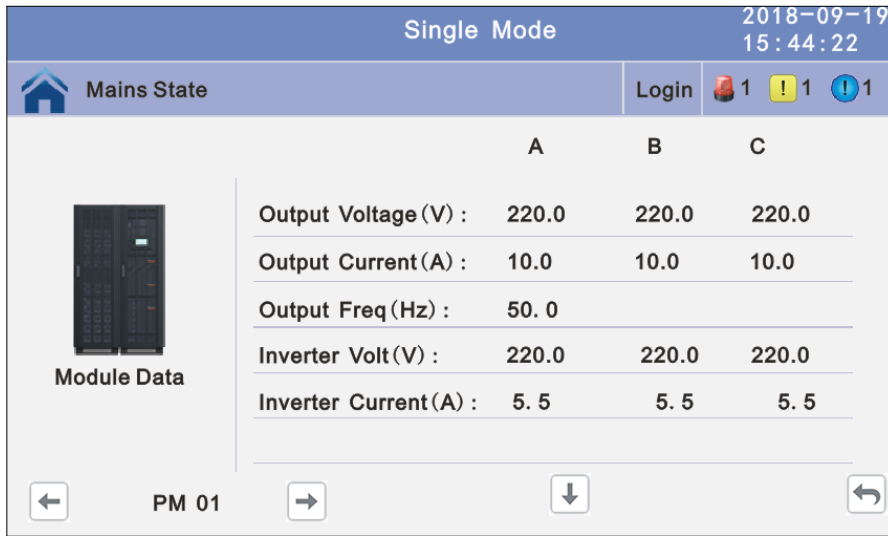

**4.3.3 Alarm:** View the alarm and history of the UPS, and open or close the buzzer.

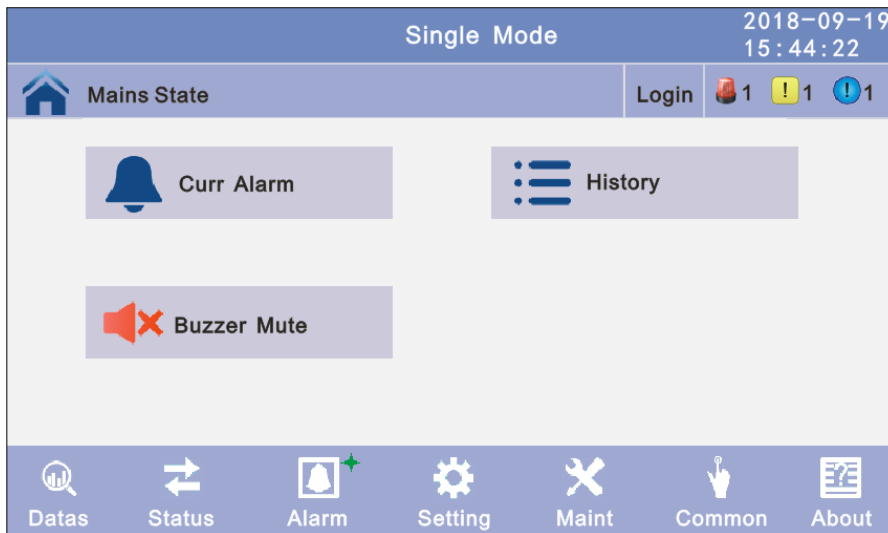

**4.3.3.1 Curr Alarm:** Click the curr alarm to enter the current alarm display window, click return to return to the previous window, click home page to return to the main page.

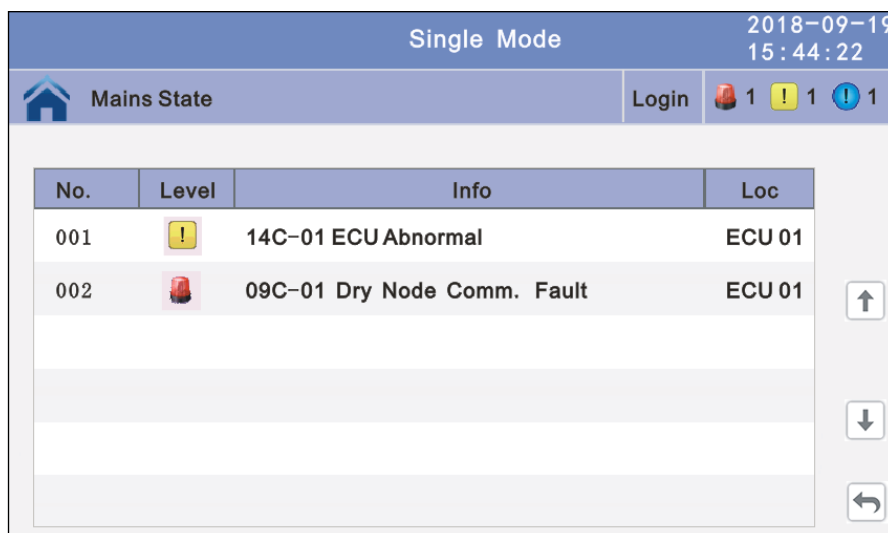

**4.3.3.2 History:** Click the history to enter the history recode display window, click return to return to the previous window, click home page to return to the main page.

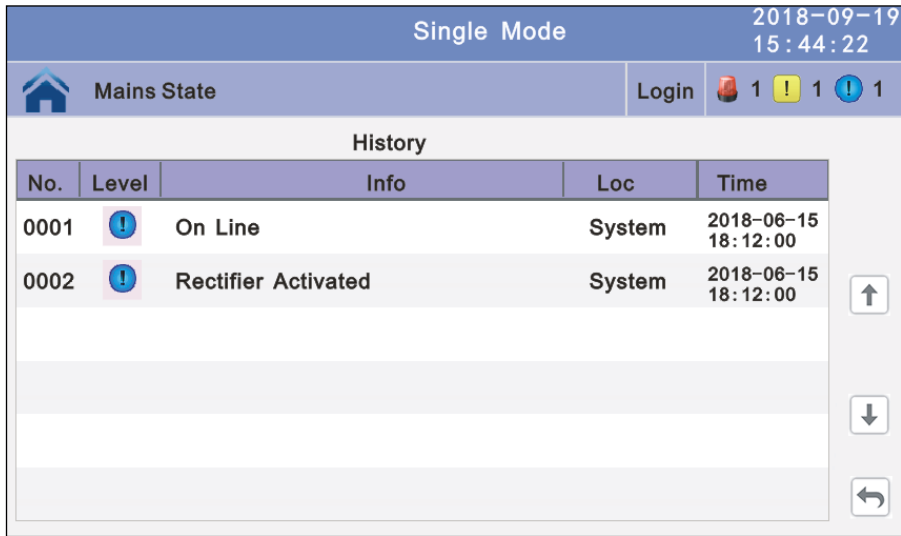

**4.3.3.3 Buzzer:** Click the buzzer mute then the buzzer will mute and the red block will change to green, if the buzzer is on, then click the block buzzer will on and the block will change to red. click return to return to the previous window, click home page to return to the main page.

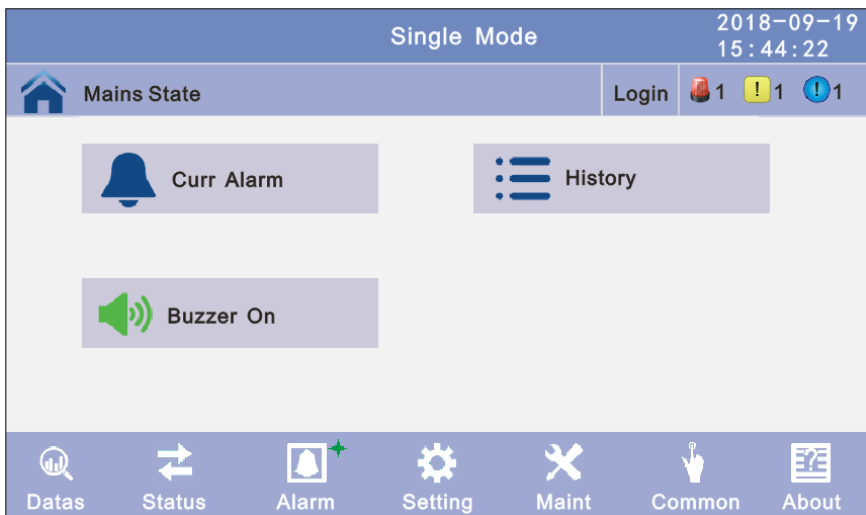
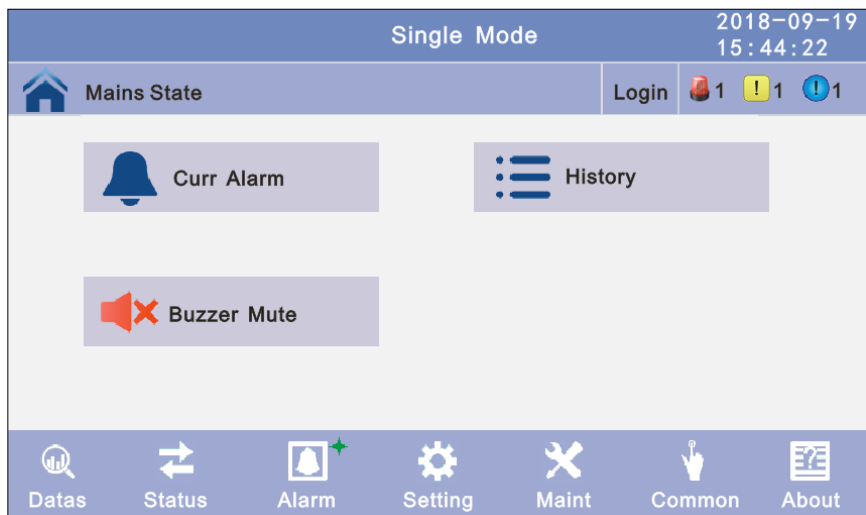

**4.3.4 Setting:** There are two levels, the basic setting for user settings, advanced setting for technical personnel, please contact the relevant technical personnel to enter advanced settings.

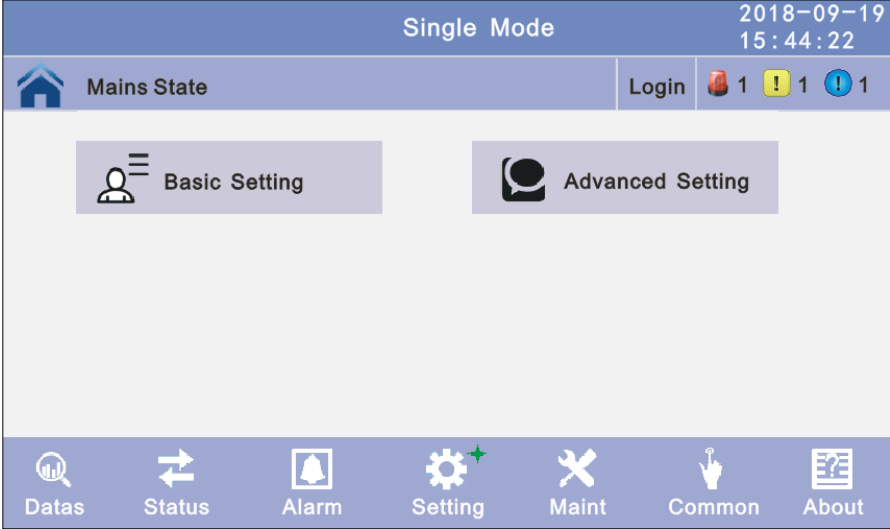

**4.3.4.1 Basic Setting:** Click basic setting, enter by input the correct password. The user password is "111111".

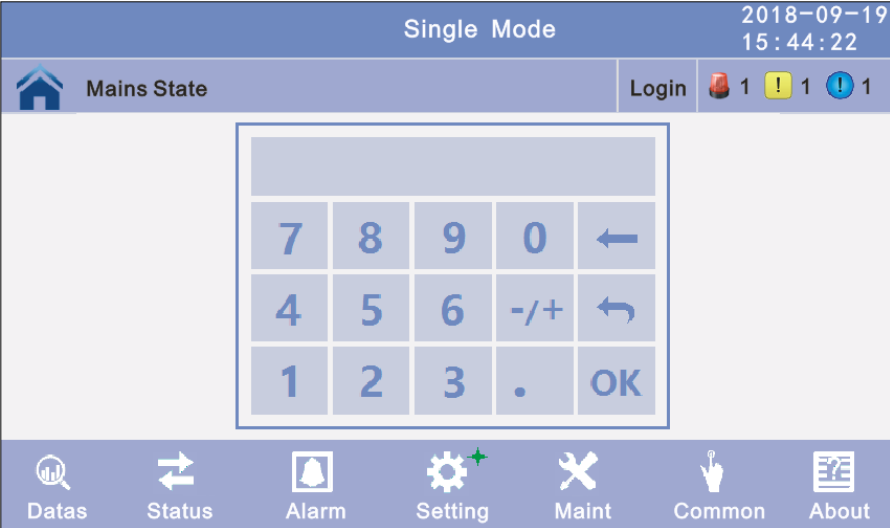
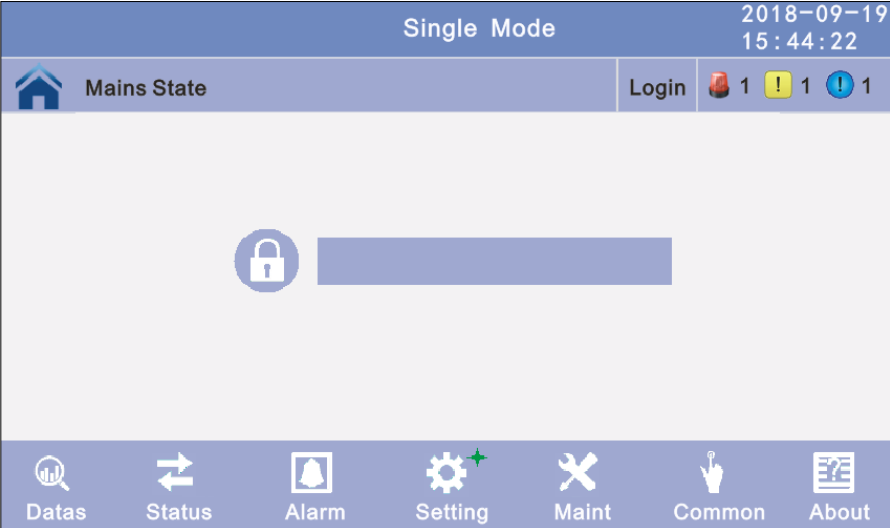

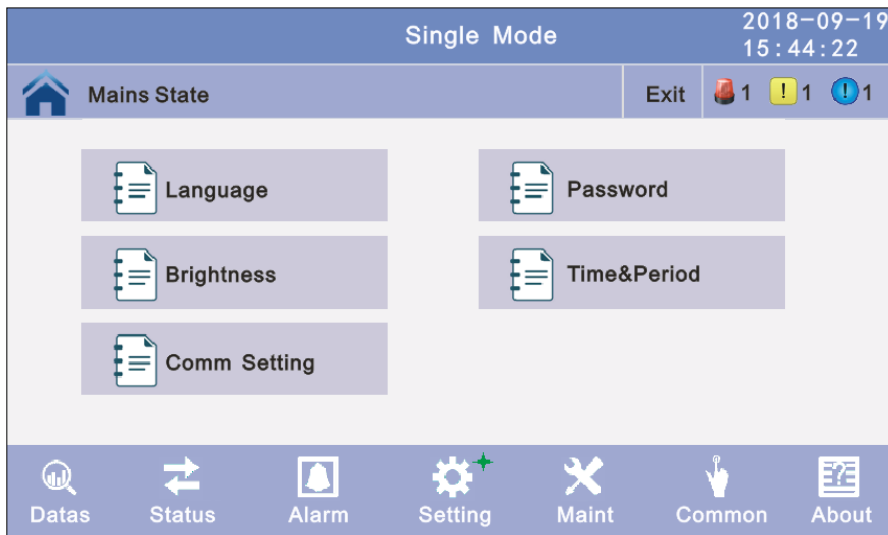

**4.3.4.1.1 Language:** Click the language block with you want and click the save config block to save. click return to return to the previous window, click home page to return to the main page.



**4.3.4.1.2 Password:** Click password block enter user password setting page, input old password and new password, then click save confirm to save the change. Password format is six numbers. click return to return to the previous window, click home page to return to the main page.

**Password lock time:** When LCD is not touched, it needs to re login when the setting value is set, click left or right block to change the value.

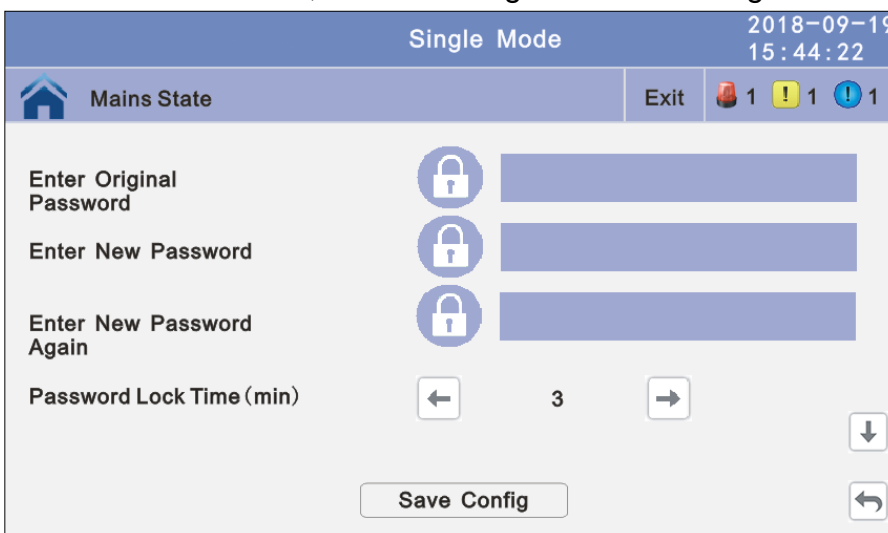

**4.3.4.1.3 Brightness and Backlight time:** Click the block to change value. click return to return to the previous window, click home page to return to the main page.

**Brightness:** Click the text to input new value and click the save config block to save. Value range is 1~63, default value is 63. Click return to return to the previous window, click home page to return to the main page.

**Backlight time:** LCD backlight delay time, click the text to input new value and click save config block to save. Value range is 1~255, default value is 60. Click return to return to the previous window, click home page to return to the main page.

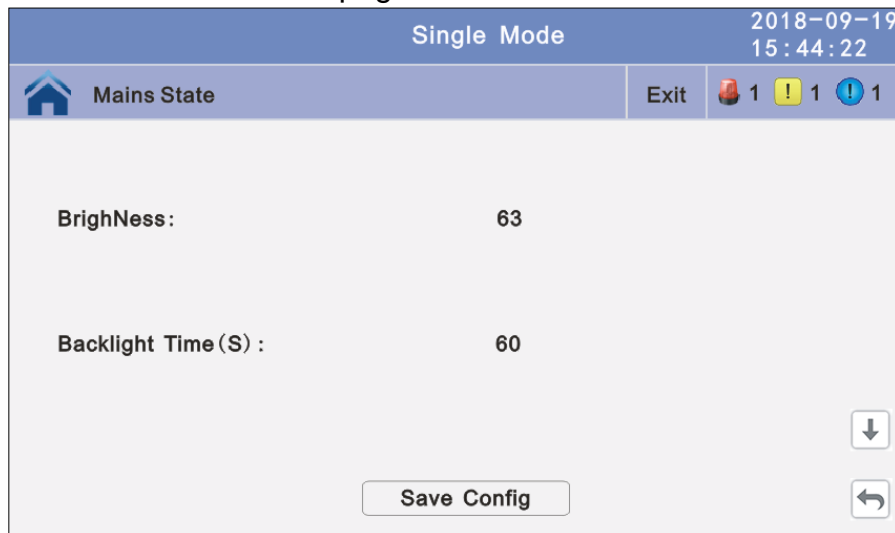

**4.3.4.1.4 Date and time setting:** Click the text to select other value or input new value and click save config block to save. Click return to return to the previous window, click home page to return to the main page.

**Date:** current date

**Time:** current time

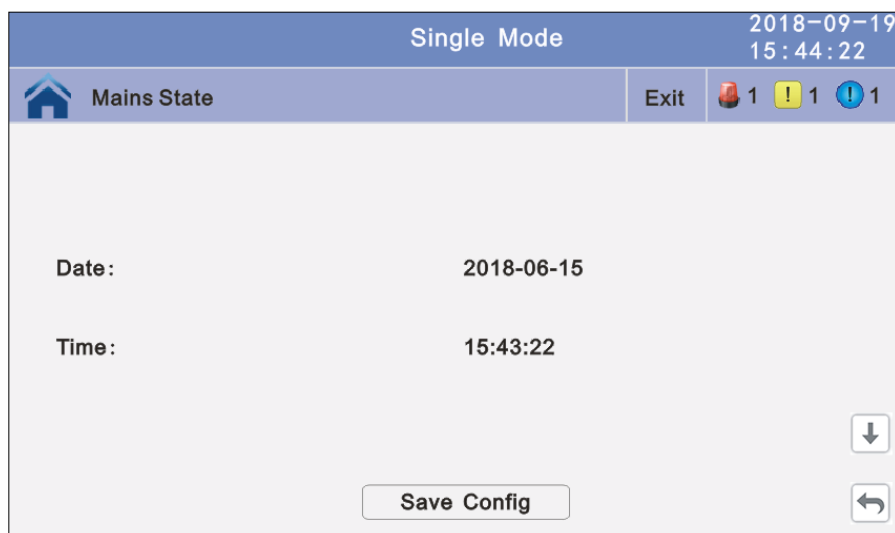

**4.3.4.1.5 Communication setting:** Click the text to select other value or input new value and click save config block to save. Click return to return to the previous window, click home page to return to the main page.

**Rs485 address:** UPS communication ID, address range is 1~15, default is 1.

**Rs485 Baud Rate:** baud rate: 2400, 4800, 9600, 14400, 19200, default is 9600



**4.3.4.2 Advanced Setting:** Click advanced setting, enter by input the correct password. Advanced setting password to be required to the UPS vendor or to its representative.

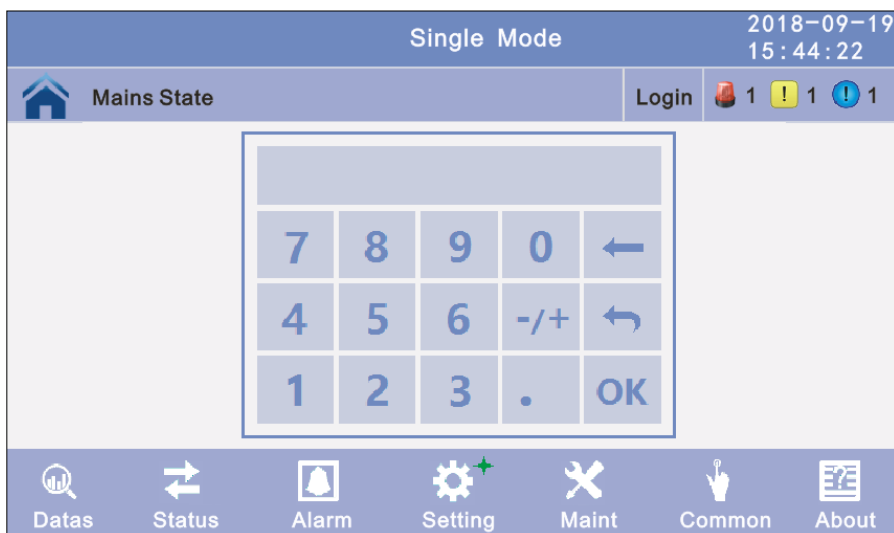
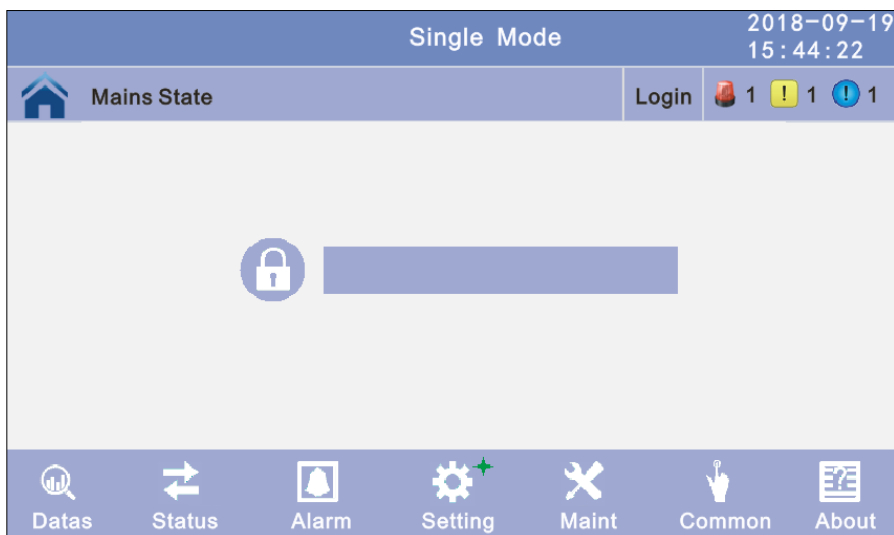



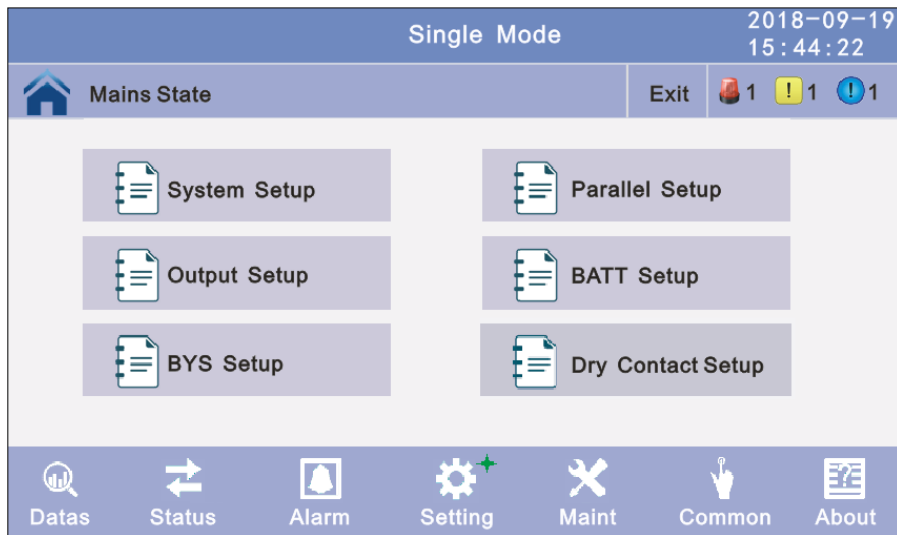

**4.3.4.2.1 System setting:** Click the text to select other value or input new value and click save config block to save. Click return to return to the previous window, click home page to return to the main page.

**Working Mode:** Select the work mode of UPS, work mode: Single mode, Parallel mode, ECO mode.

**Auto Turn-on:** Select the UPS start logic, Enable: UPS start inverter output automatic, Disable: No output.

**Aging Load Rate:** The value can be 18~100%, default value: 60%.



**Freq Conv Mode:** Frequency conversion mode, enable: output frequency set 50Hz or 60Hz, input frequency is 60Hz or 50Hz, UPS no alarm not battery and bypass abnormal. Default is Disable.

**LBS mode:** setting value: LBS disable, LBS master, LBS slave. Default is LBS disable.

**Temp Sensor Switch:** temperature sensor compensation switch, when need to connect battery temperature sensor, please change the value to enable.

**Temp Sensor Select:** temperature sensor type select. Has tow types: NTC and RS485. NTC for single and short distance. Rs485 for multiple and far distance.

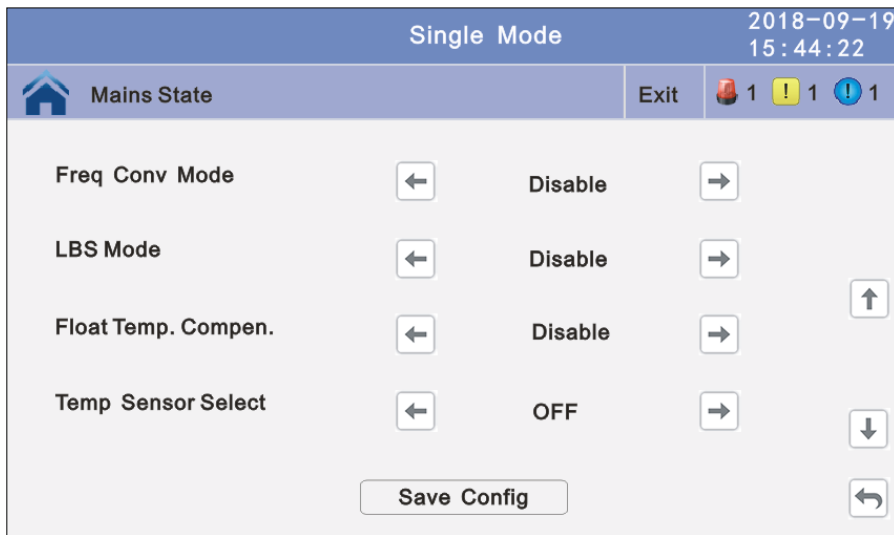

**Power Walk in:** this is enable the UPS to control the interval that each module transfers from battery mode to normal mode, which reduces the impact on the generator or power grid. The value can be 1~20, default value is 1.

**Inter Power Walk in:** this is enable the UPS to control the interval that each rack transfers from battery mode to normal mode, which reduces the impact on the generator or power grid. The value can be 0~200, default value is 10.

**Inter sleep mode:** when load less than the software setting value, same parallel rack will turn to standby mode and if the load more than the setting value some rack will turn to inverter mode after setting the sleep mode enable. Default value is disable.



**Basic Unit Numb:** power module number for actual configuration, if setting number no the same to actual number, UPS will alarm.

**Cabinet Power:** cabinet power range, the same power range of bypass.

**Sleep Mode:** when load less than the software setting value, same power module will turn to standby mode and if the load more than the setting value some power module will turn to inverter mode after setting the sleep mode enable. Default value is disable.

Single Mode		2018-09-19 15:44:22	
Mains State	Exit	1	1  1
Basic Unit Num:	<input type="text" value="12"/>	<input type="text" value="12"/>	<input type="text" value="12"/>
Cabinet Power (kVA) :	<input type="text" value="500.0"/>	<input type="text" value="500.0"/>	<input type="text" value="500.0"/>
Sleep Mode:	<input type="text" value="Disable"/>	<input type="text" value="Disable"/>	<input type="text" value="Disable"/>
<input type="button" value="Save Config"/>			<input type="button" value="↶"/>

**Parallel ID:** Parallel operation ID, must modify the ID after set work mode to parallel mode. The value can be 1~6, default value is 1.

**Cabinet Paral Basic Units:** Parallel cabinet number, must modify the total parallel cabinet number after set work mode to parallel mode. The value can be 2~6, default value is 2.

**Cabinet Paral Redunt Units:** Parallel redundancy cabinet number, can modify the redundancy cabinet number after set work mode to parallel mode. The value can be 0~5, default value is 0.

Single Mode		2018-09-19 15:44:22	
Mains State	Exit	1	1  1
Parallel ID	<input type="text" value="1"/>	<input type="text" value="1"/>	<input type="text" value="1"/>
Cabinet Paral Basic Units	<input type="text" value="2"/>	<input type="text" value="2"/>	<input type="text" value="2"/>
Cabinet Paral Redund Units	<input type="text" value="0"/>	<input type="text" value="0"/>	<input type="text" value="0"/>
<input type="button" value="Save Config"/>			<input type="button" value="↶"/>

**Output Freq:** Output frequency, The value can be 50Hz or 60Hz.

**Output Volt Level:** Output voltage level, The value can be 220V, 230V, 240V.

**Inverter Volt Adajust:** Inverter voltage adjust, The value can be -5%~0~+5%, step is 0.5%, default value: 0.

Single Mode		2018-09-19 15:44:22	
Mains State	Exit	1	1  1
Output Freq (Hz)	<input type="text" value="50.0"/>	<input type="text" value="50.0"/>	<input type="text" value="50.0"/>
Output Volt Level (V)	<input type="text" value="220.0"/>	<input type="text" value="220.0"/>	<input type="text" value="220.0"/>
Inverter Volt Adjust (%)	<input type="text" value="0.0"/>	<input type="text" value="0.0"/>	<input type="text" value="0.0"/>
<input type="button" value="Save Config"/>			<input type="button" value="↶"/>

**Battery type:** Must modify the battery type to actual configuration, when use VRLA Battery choose the VRLA, when use Li battery choose Li battery.

**No Battery Warning:** Can be no warning when no batter after set disable, and is enable by default.

**Cabinet shared battery:** Tow parallel ups use common batter bank. The value can be set Disable and enable, disable by default.

**Generator on prohibit charging:** UPS disable charge the battery if set the value to enable when the generator signal is enable.

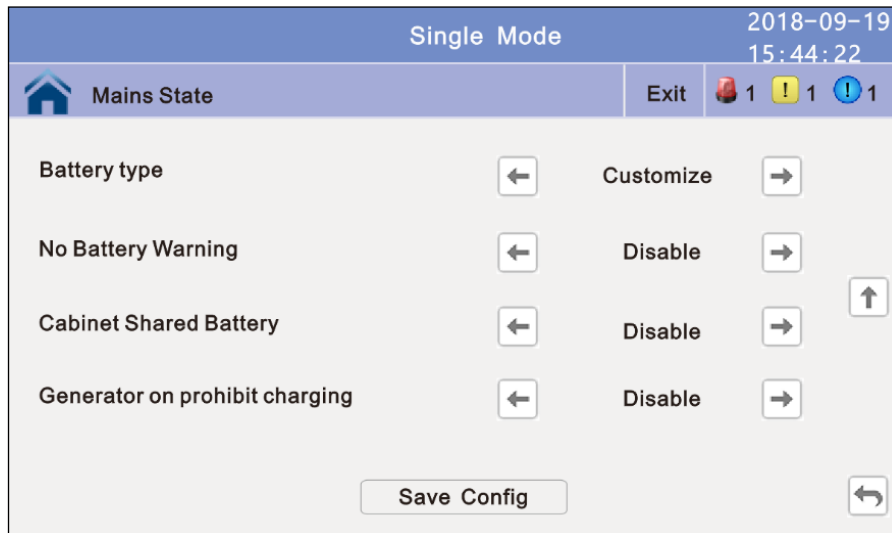

**Battery Group 1:** Must modify the group number to actual configuration, The value can be 1~8, default value is 1.

**Battery Group 2:** This option needs to be set when multiple sets of batteries are required and connected to the battery breaker auxiliary contact and trips. Must modify the group number to actual configuration, The value can be 1~8, default value is 1.

**Battery Group 3:** This option needs to be set when multiple sets of batteries are required and connected to the battery breaker auxiliary contact and trips. Must modify the group number to actual configuration, The value can be 1~8, default value is 1.

**Single Battery Volt:** Must modify the voltage to actual configuration, The value can be 2 or 12, default value is 12, for VRLA Battery.

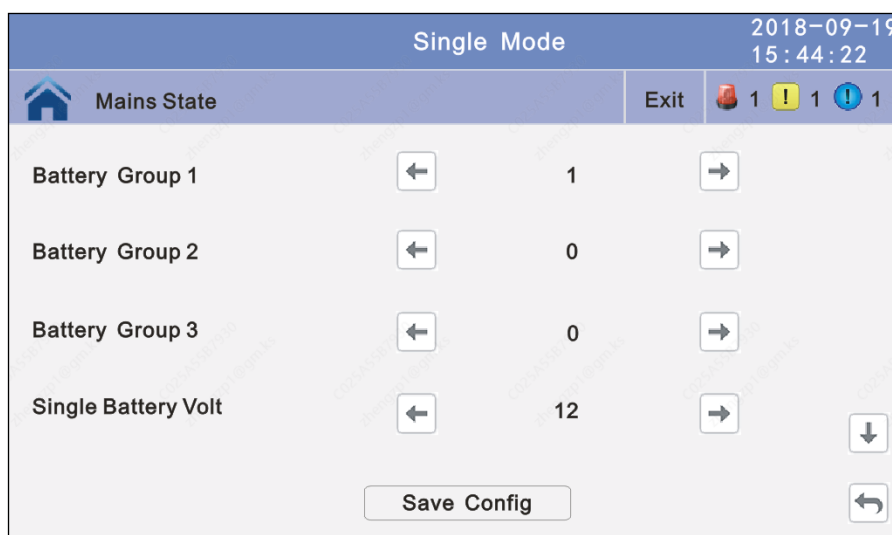

**Battery number:** Must modify the battery number to actual configuration, The value can be 30~50, default value is 30, for VRLA Battery.

**Single Battery Capability:** Must modify the value to actual configuration, the value can be 7~2000, for VRLA Battery.

**Boost/Float conversion:** Boost charge and float charge alternate time, the value can be 0~20, for VRLA Battery.

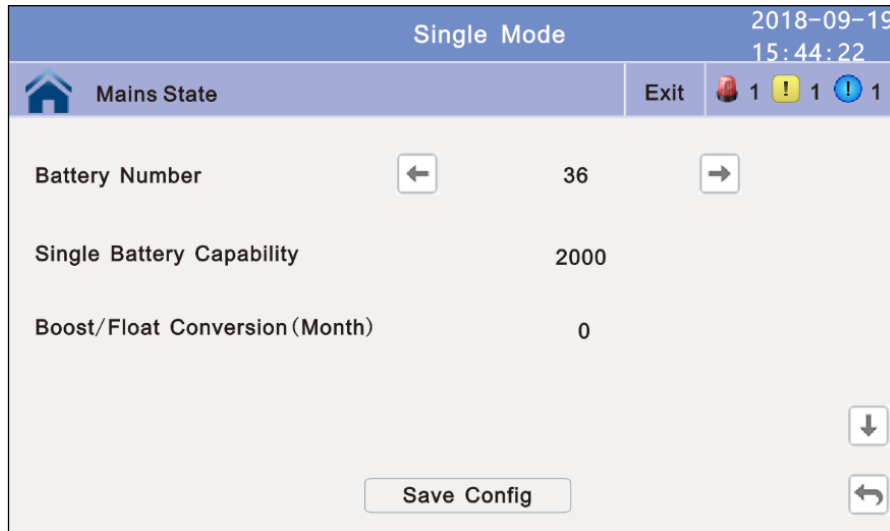

**Chg.cur.limiting coef.:** The charging current limit is a multiple of the battery capacity. The value can be 0.05–0.15, and is 0.1 by default, for VRLA Battery.

**Cell float voltage:** The float voltage value can be 2.23-2.30 V/cell, and is 2.25 V/cell by default, for VRLA Battery.

**Cell boost voltage:** The battery equalized voltage value can be 2.30–2.40 V/cell, and is 2.30 V/cell by default, for VRLA Battery.

**Aver charging Duration:** boost charge time limit, the value can be 1–999min, and is 240 by default, for VRLA Battery.



**EOD Battery Volt:** End of discharge voltage. The value can be 1.60~1.90, and is 1.80 by default, for VRLA Battery.

**Float Temp Compenn Coeff:** Modify the voltage of compensation after enable the switch. the value can be 0.001~0.007/cell, and is 0.003 by default, for VRLA Battery.

**Boost Charge Setting:** Boost charge disable or enable, and is enable by default, for VRLA Battery.

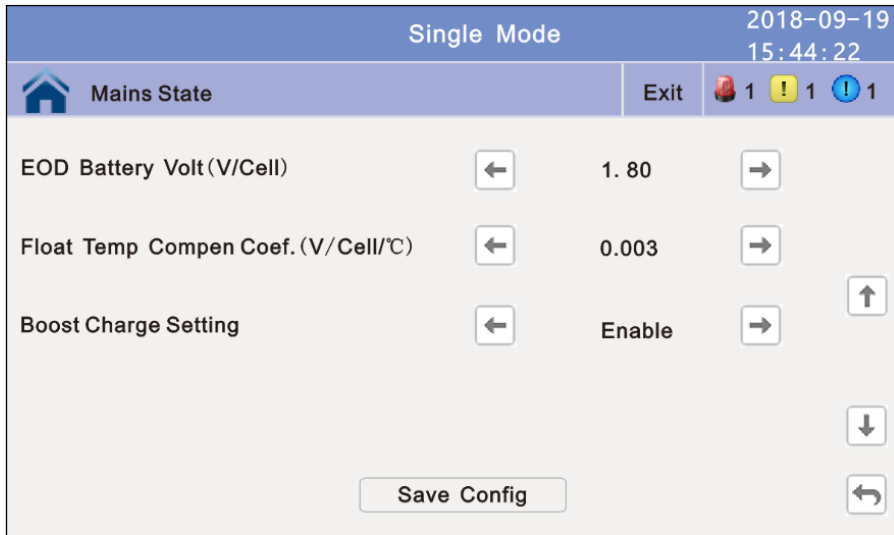

**Battery Cluster Num:** set the cluster number of Li battery after set the battery type to “KLI-512”.

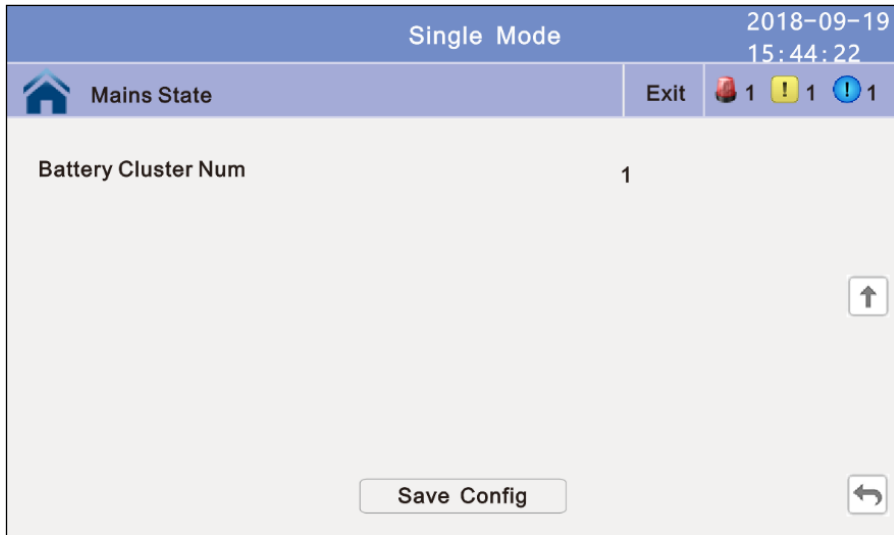

**Neutral Cable Setting:** set the battery cabling type, disable is battery not neutral, enable is battery has neutral. Disable is default value.

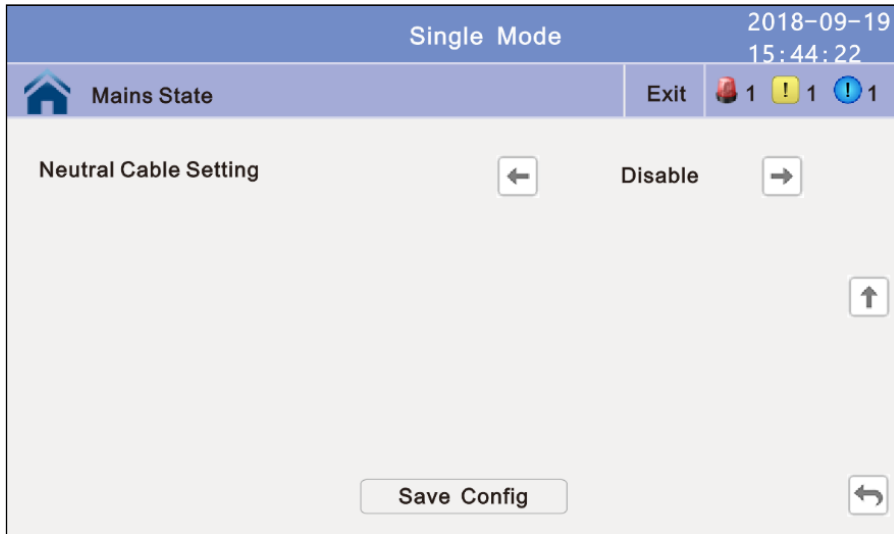

**Bypass Volt Prot Lower Limit:** When the difference between the bypass voltage and the rated voltage exceeds the lower threshold for the bypass voltage, the system determines that the bypass voltage is abnormal and that the bypass is unavailable. The value can be -10%, -15%, -20%, -30%, -45%,. The default value is -45%.

**Bypass Volt Prot Limit:** When the difference between the bypass voltage and the rated voltage exceeds the upper threshold for the bypass voltage, the system determines that the bypass voltage is not normal and that the bypass is unavailable.

NOTE:

When the voltage level is 380 V, the value range is 10%, 15%, 20%, and 25% (default).

When the voltage level is 400 V, the value range is 10%, 15%, and 20% (default).

When the voltage level is 415 V, the value range is 10% and 15%(default).

**Bypass Freq Tracking Range:** When the difference between the bypass input frequency and the rated frequency is greater than this value, the system determines that the bypass frequency is not normal, and that the bypass is unavailable. The value range is 1%, 2%, 4%, 5%, 10%(default).

**Bypass rate tracking rate:** Inverter frequency tracking to bypass frequency rate. The value range is 0.5~2, and is 1 by default.

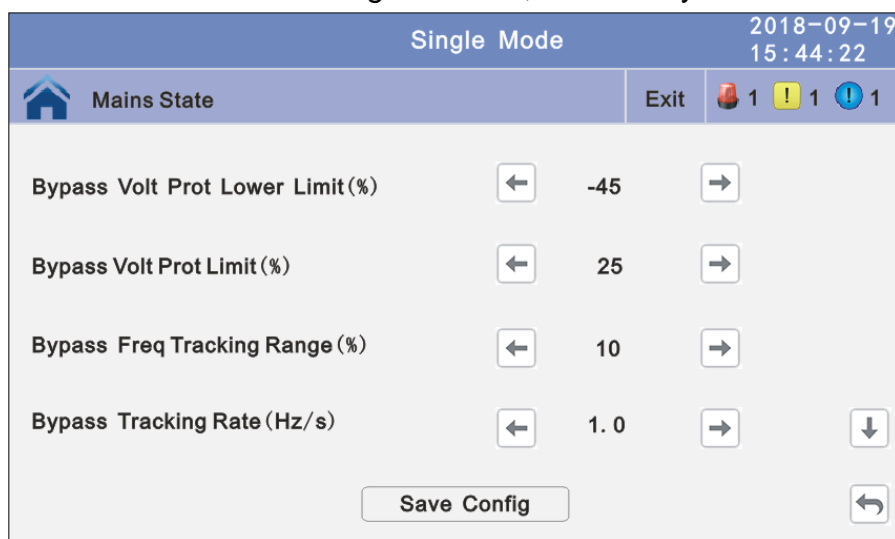

**Power Supply upon BYP SCR Overtemp.:** Specifies whether to start bypass mode when overtemperature occurs. The default value is Enable.

**Bypass Switches Limit:** Cross currents occur during the transfer between bypass mode and normal mode, which impacts the system. This parameter specifies the number of transfers between bypass mode and normal mode within 1 hour, which ensures system security. The value can be 3 to 10, and is 10 by default.

**EPO transfers to bypass:** Specifies whether to start bypass mode when EPO occurs. The default value is Enable.

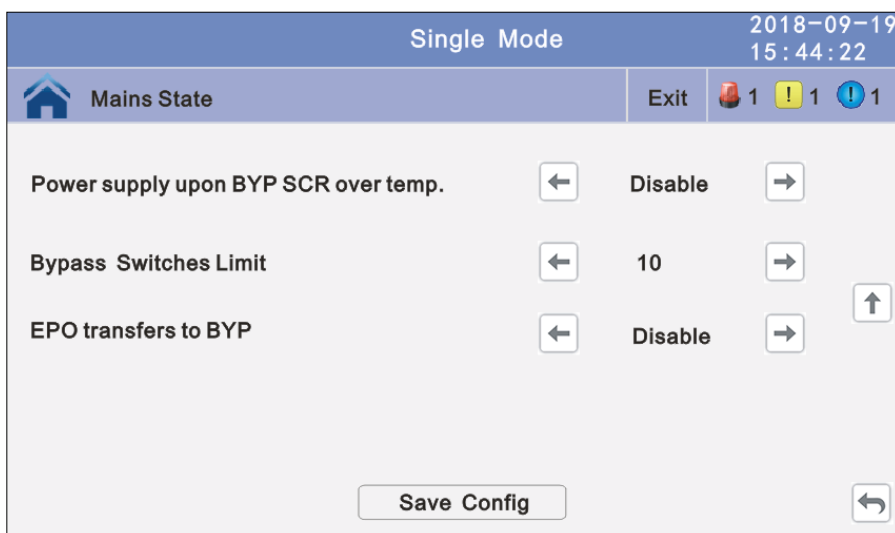



**Battery Abnormal BCB trip(DRV):** Enable or disable BCB trip single output. The default value is Disable.

**Bypass Feedback Trip:** Enable or disable bypass feedback output. The default value is Disable.

**External Maint. breaker:** Enable or disable external maintenance breaker connection detection. The default value is Disable.

**BATT Switch(BAT):** Enable or disable battery breaker connection detection. The default value is Disable.

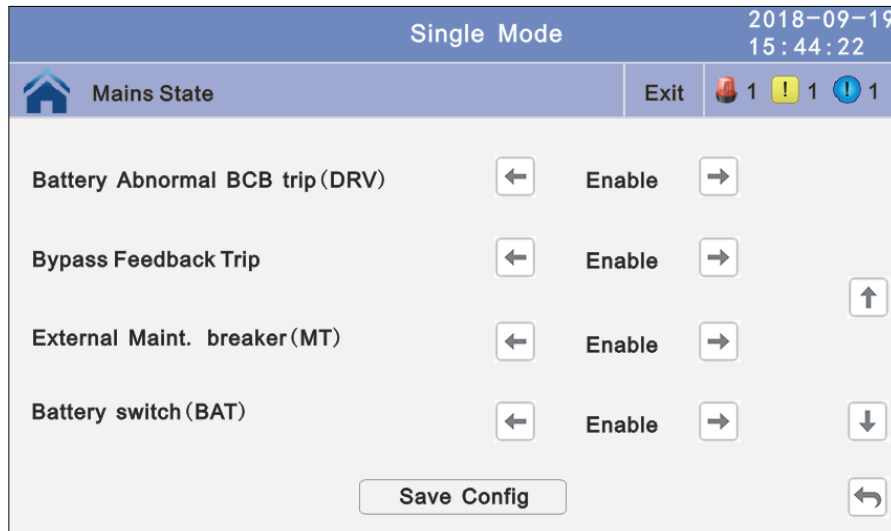

**Output Switch:** Enable or disable output breaker connection detection. The default value is Disable.

**BYP Switch:** Enable or disable bypass breaker connection detection. The default value is Disable.

**BATT Ground Fault:** Enable or disable battery grounding failure detection. The default value is Disable.

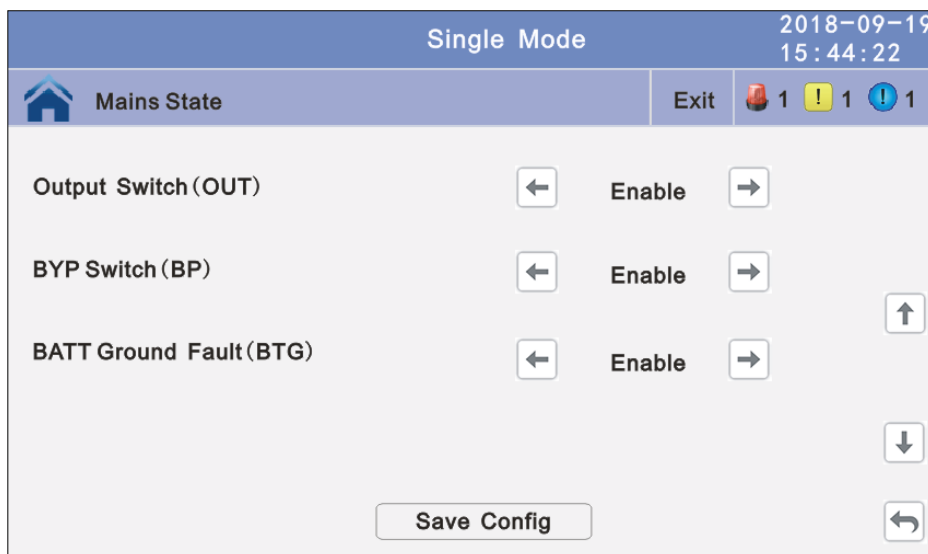

**Lightning arrester (SPD) :** Enable or disable SPD detection. The default value is Disable.

**Generator (GEN) :** Enable or disable GEN detection. The default value is Disable.



**OUT01~OUT06:** Output dry contact port, modify on the LCD, the default value is Disable. The output port can set to normally closed or normally open, The default value is normally opened.

Setting value:

No.	Item	No.	Item
1	URGENT_ALARM	7	BYPASS_SUPPLY
2	MINOR_ALARM	8	BATTERY_SUPPLY
3	MAIN ABNORMAL	9	NO_SUPPLY
4	BATTERY_LOW_VOLT	10	ECO_MODE
5	BATTERY_SELFHECK	11	BMS cold start
6	MAIN_SUPPLY		

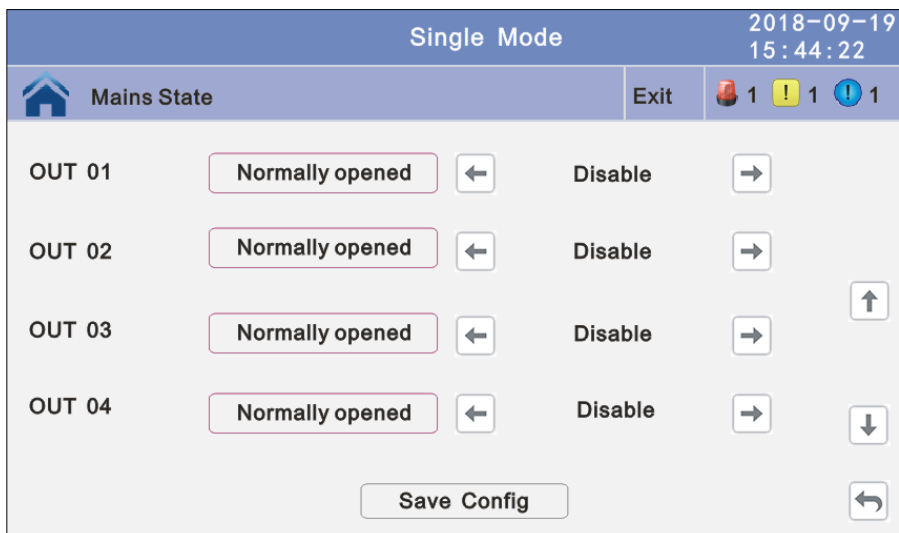

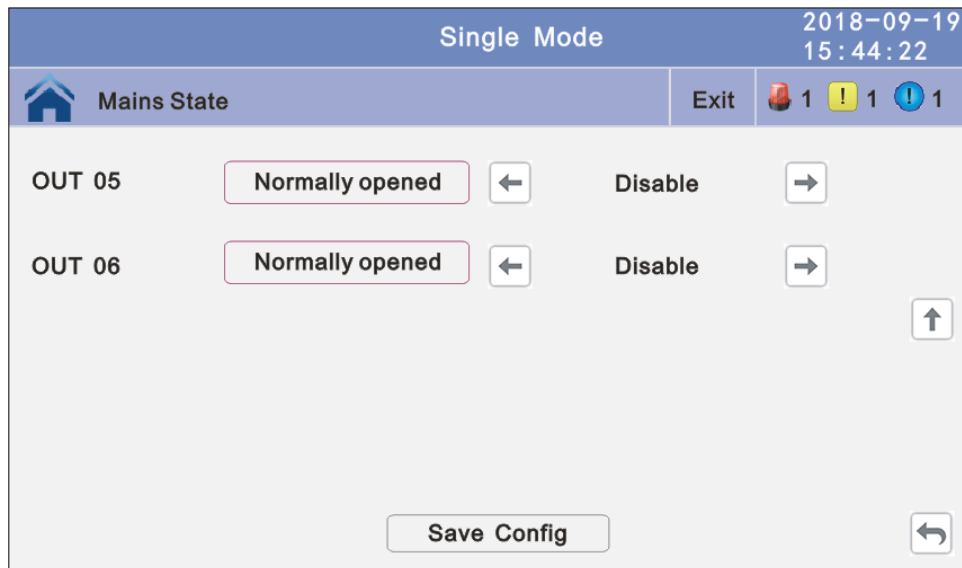

**IN01~IN04:** Output dry contact port, modify on the LCD. The default value is Disable.

Setting value:

No.	Item	No.	Item
1	INV ON	7	Disable ECO
2	INV OFF	8	Forced INV OFF
3	Battery inoperable	9	Forced Charger OFF
4	Rack Overtemp.	10	Transformer Overtemp.
5	Custom alarm 3	11	Firefighting Alarm
6	Custom alarm 4	12	BMS internal Fault



#### 4.3.5 Maint: Software update, Touch correction, history download and battery self-test.

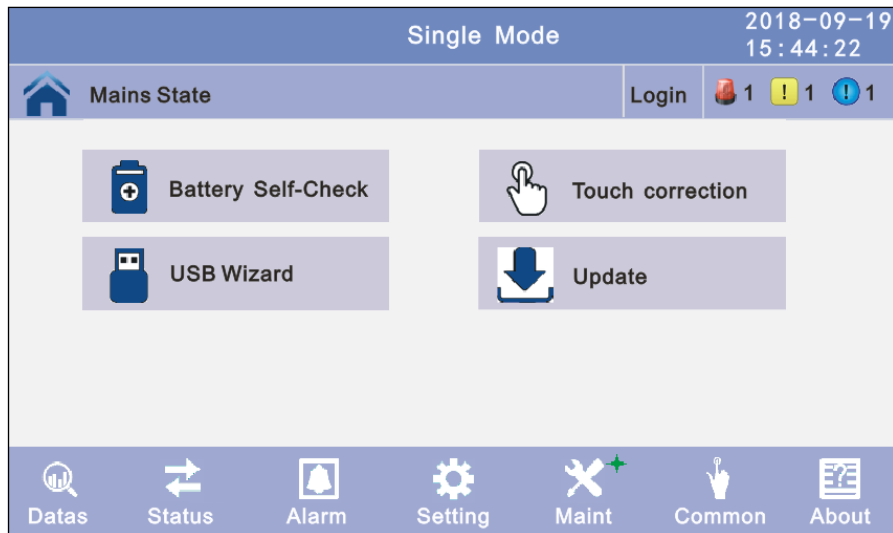

##### 4.3.5.1 USB Wizard: History Output, download history and setting record by USB

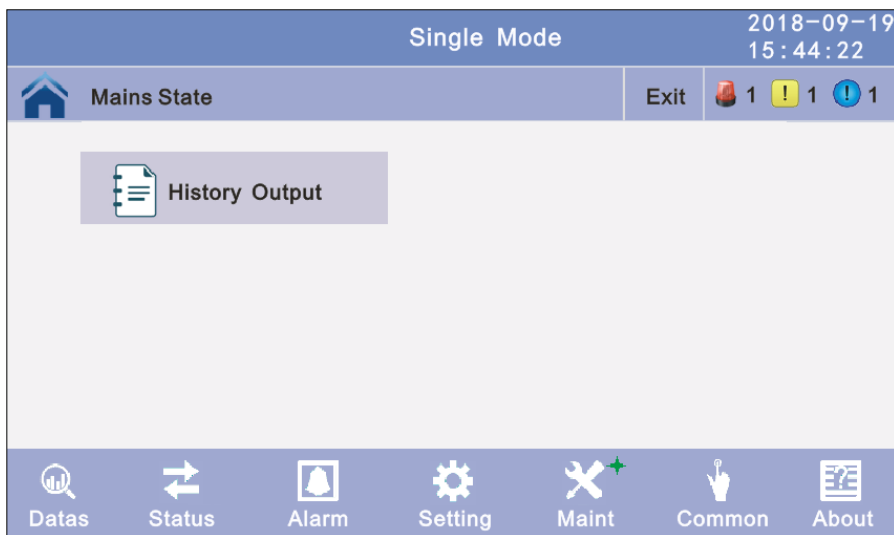

##### 4.3.5.1.1 Alarm Log Output

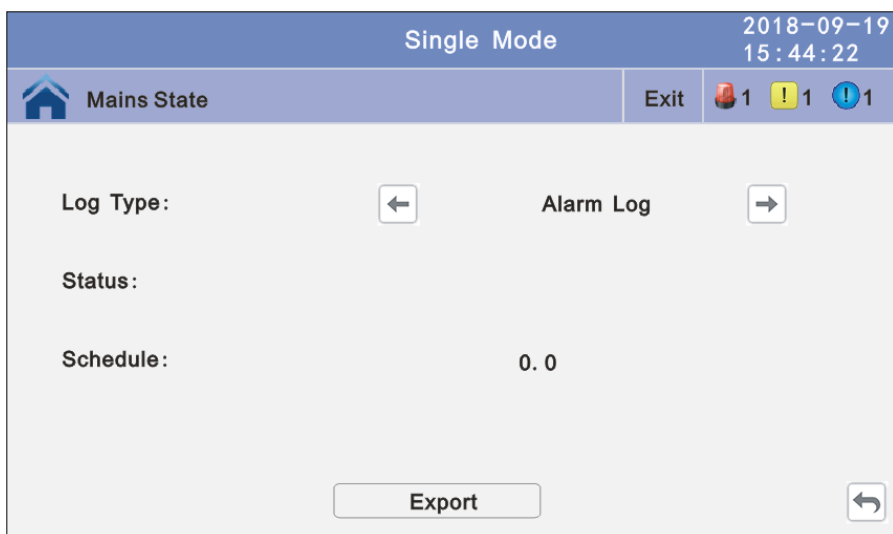

#### 4.3.5.1.2 Setting Log Output:

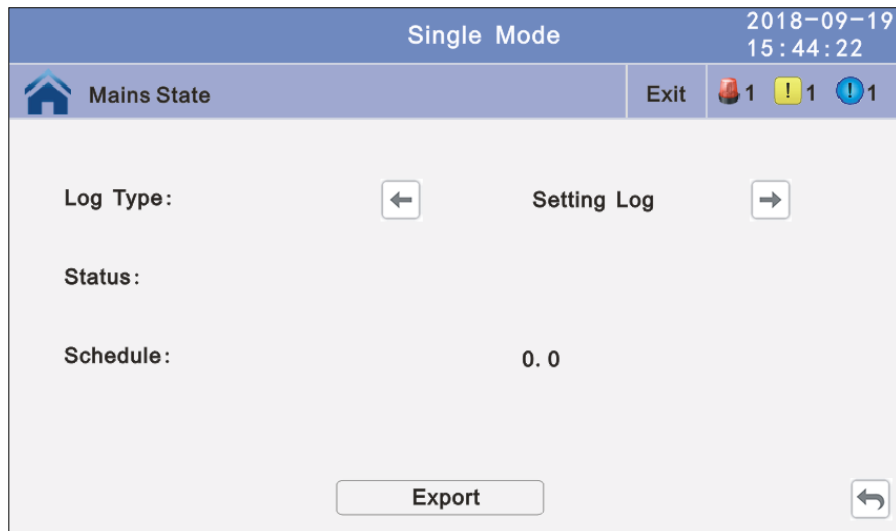

**4.3.5.2 Battery Self-Check:** can select check by Timing Daily, Timing Weekly, Cycle mode. The default value is Timing Self-Check Close.

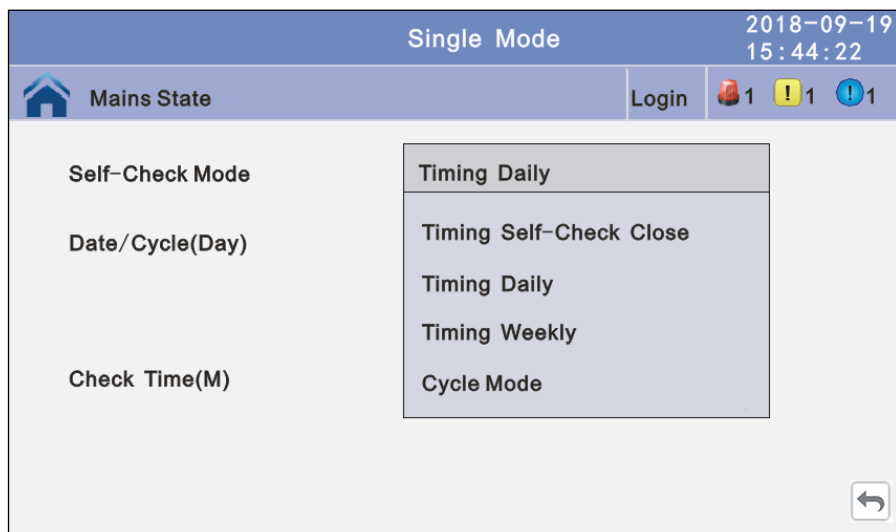

**4.3.5.2.1 Timing Daily:** modify the check date, time and check time (10S (default), 10min, EOD).

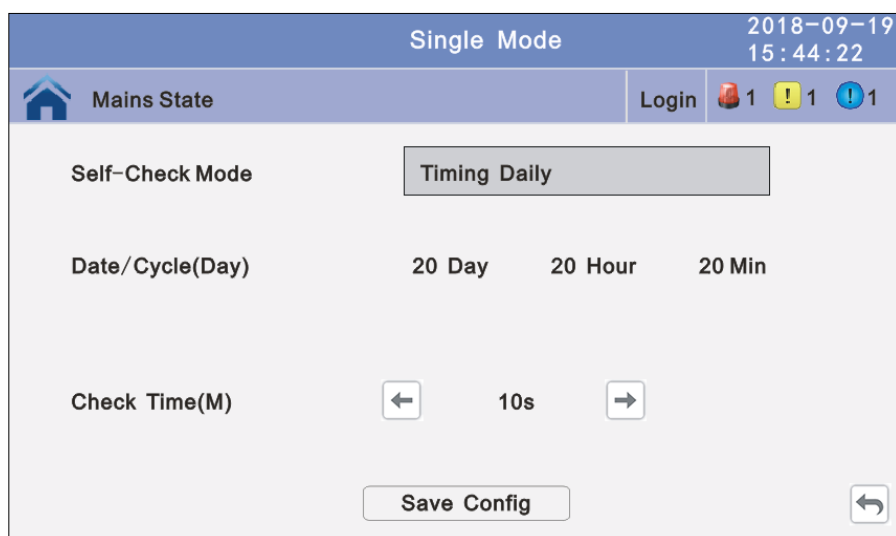

**4.3.5.2.2 Timing Weekly:** modify the check date, time and check time (10S (default), 10min, EOD).

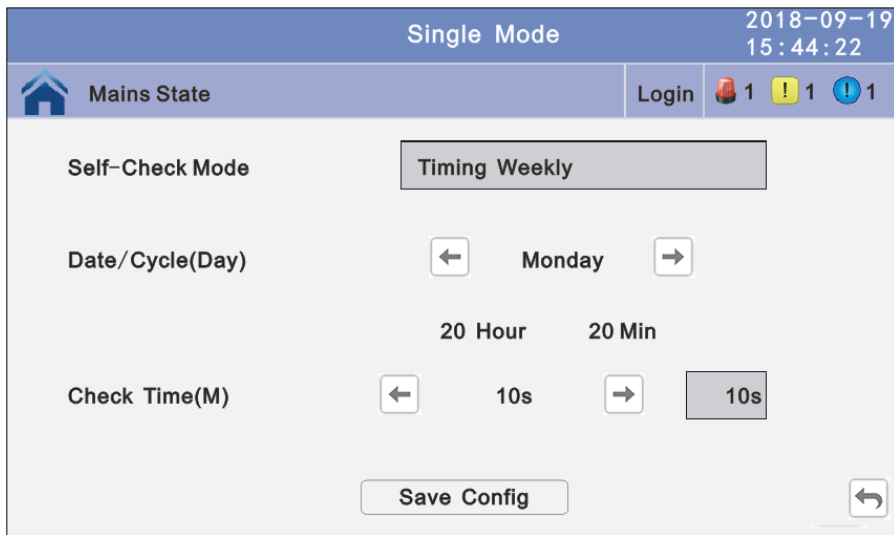

**4.3.5.2.3 Timing Cycle mode:** modify the cycle date and check time (10S (default), 10min, EOD).

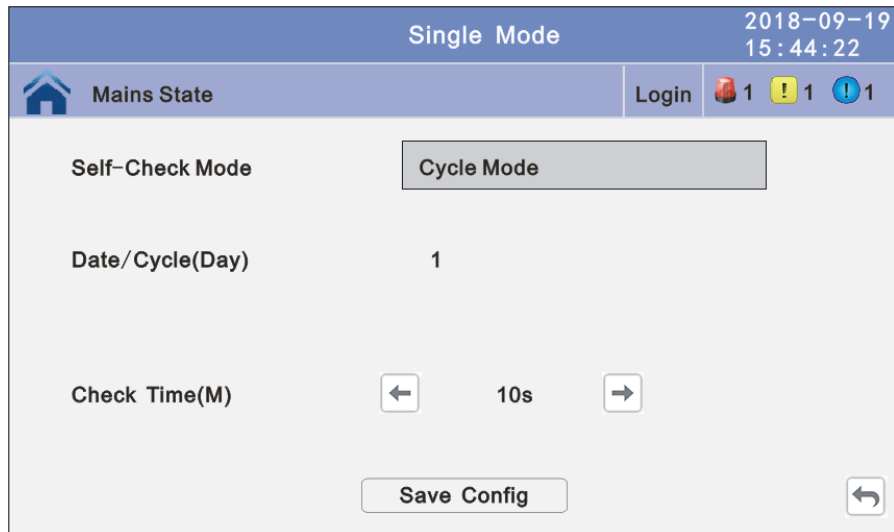

**4.3.6 Common:** INV ON/OFF, Battery test and Fault clear.

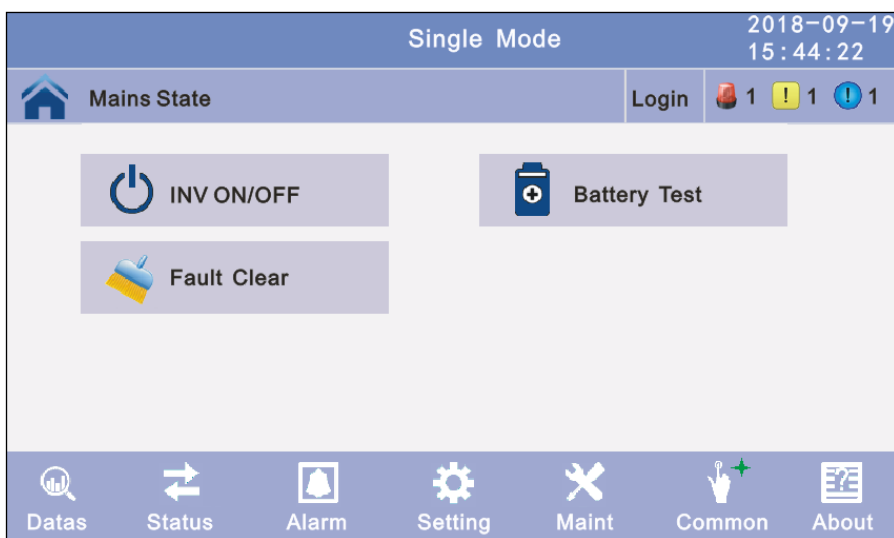

**4.3.6.1 INV ON/OFF**

**Single OFF:** Inverter OFF location UPS

**Single ON:** Inverter ON location UPS

**Parallel OFF:** Inverter OFF all parallel UPSs

**Parallel ON:** Inverter ON all parallel UPSs

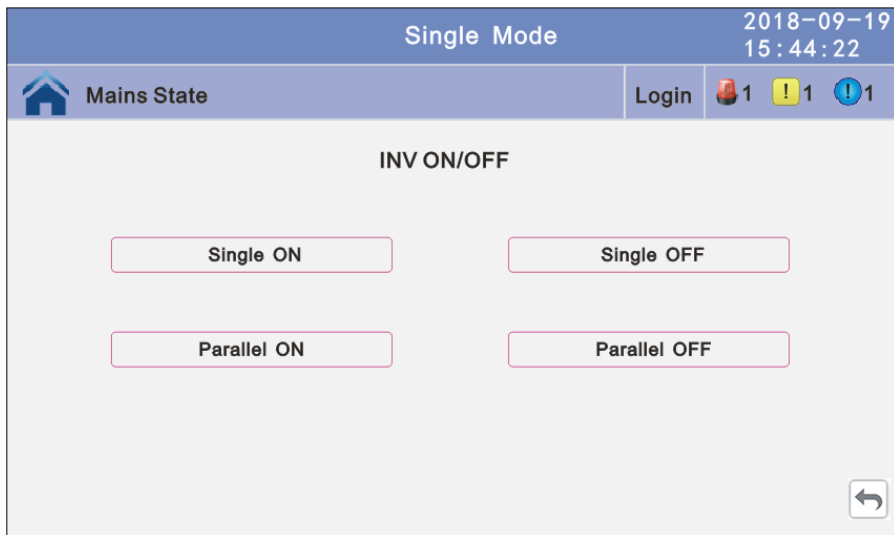

#### 4.3.6.2 Battery Test

**10S:** battery test for 10s

**10min:** battery test for 10min

**EOD:** battery test to EOD

**-10%:** battery test down 10% capability.

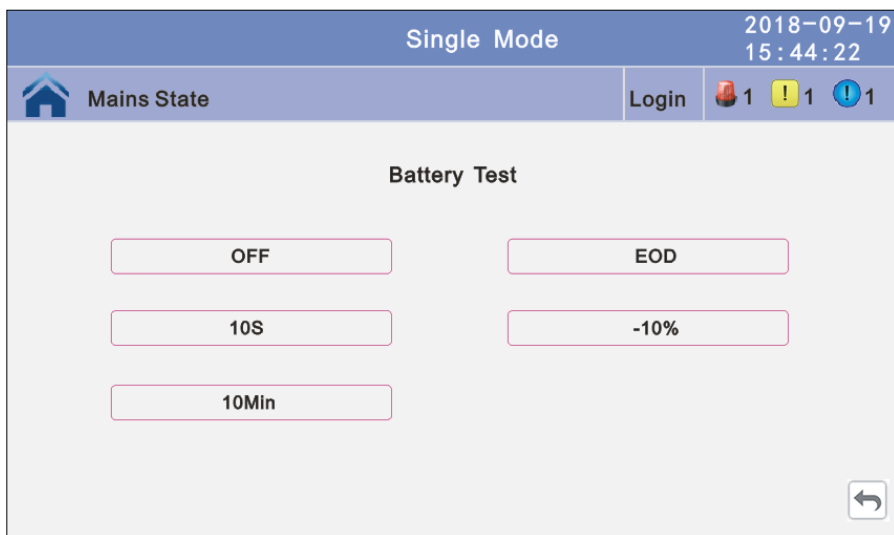

#### 4.3.6.3 Fault clear: Clear the current fault (not for all faults).

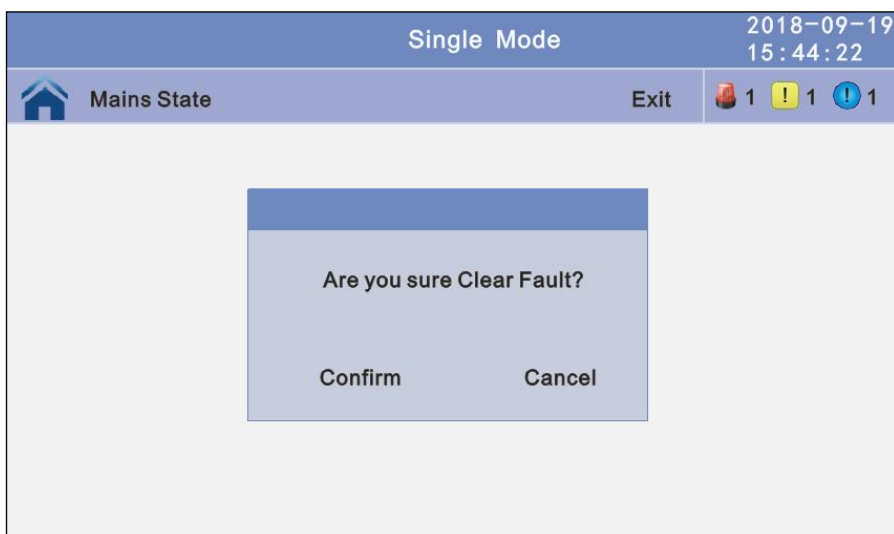



### 4.3.7 About: check the software version

#### 4.3.7.1 Monitor and LCD software version

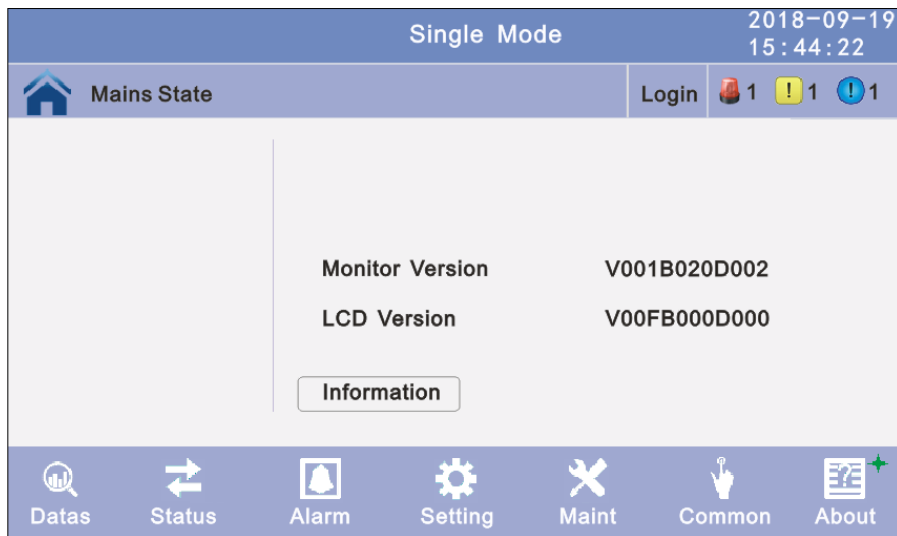

#### 4.3.7.2 Internal software version

**Power module software version:** PFC DSP, PFC CPLD, INV DSP and INV CPLD.

**Center control unit (ECU) software version:** DSP and PFGA

**Bypass module software version:** DSP and CPLD

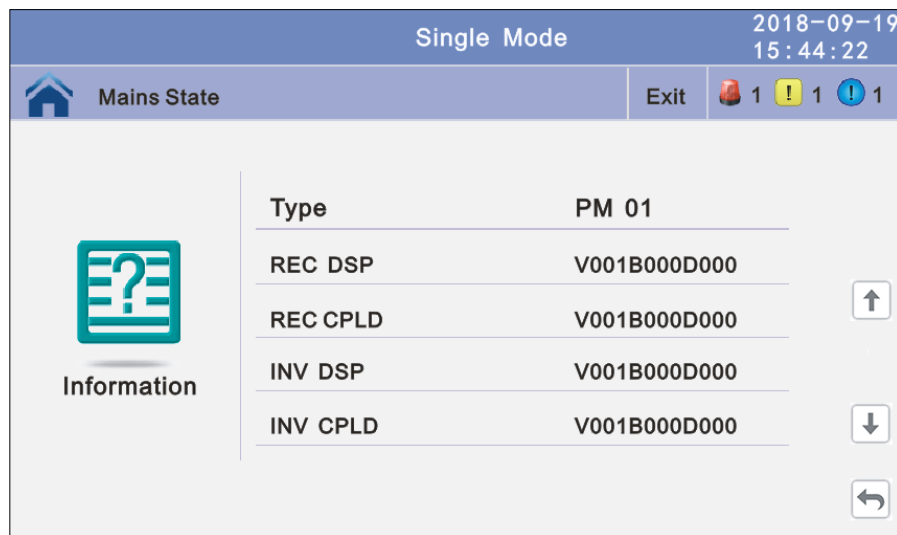

### 4.4 Display Messages/Troubleshooting

This section lists the event and alarm messages that the UPS might display. The messages are listed in alphabetical order. This section is listed with each alarm message to help you troubleshoot problems.

#### Fault and alarm Information

No.	Cord	Fault	Buzzer	Fault LED	Alarm LED
1	002	REC Over Temperature	Twice per second	Light	
2	003	REC Par. Cable Fault	Twice per second	Light	
3	004	REC Over Curr	Once per second	Light	
4	005	REC Power Fault	Beep continuously	Light	
5	007	Input SCR Fault	Beep continuously	Light	
6	00A	DisChage SCR Fault	Beep continuously	Light	

7	00C	Charge SCR Fault	Beep continuously	Light	
8	00E	Fan Fault	Beep continuously	Light	
9	012	Charger Over Temp.	Beep continuously	Light	
10	013	Soft Start Failed	Beep continuously	Light	
11	014	BAT Charger Fault	Beep continuously	Light	
12	016	REC Comm. Fault	Once per 2 seconds	Light	
13	019	REC Initializes Fault	Twice per second	Light	
14	01D	Unit Connected fault	Once per 2 seconds	Light	
15	01E	Rectifier Fault	Beep continuously	Light	
16	041	Inverter Fault	Beep continuously	Light	
17	044	INV IGBT SHORT	Beep continuously	Light	
18	047	Inverter Relay Short	Beep continuously	Light	
19	04A	Inverter Relay Broken	Beep continuously	Light	
20	04D	INV Par.cable Fault	Twice per second	Light	
21	051	Output Short Circuit	Once per second	Light	
22	054	INV Comm. Fault	Once per 2 seconds	Light	
23	057	INV Initializes Fault	Beep continuously	Light	
24	05A	INV Self-test Fault	Beep continuously	Light	
25	05E	DC Component Fault	Once per 2 seconds	Light	
26	061	DC Bus abnormal	Beep continuously	Light	
27	063	Unit Insert Fault	Once per 2 seconds	Light	
28	064	INV Power Fault	Beep continuously	Light	
29	067	INV Over Temperature	Twice per second	Light	
30	068	Load Sharing Fault	Twice per second	Light	
31	06A	Rack Mode Fault	Beep continuously	Light	
32	06B	Fuse Broken	Beep continuously	Light	
33	081	Par. Cable Fault	Twice per second	Light	
34	086	ECU Insert Fault	Once per 2 seconds	Light	
35	088	ECU Power Fault	Beep continuously	Light	
36	08B	ECU Comm. Fault	Once per 2 seconds	Light	
37	08D	ECU Initializes Fault	Beep continuously	Light	
38	091	BYP SCR Broken	Beep continuously	Light	
39	094	BYP SCR Short	Beep continuously	Light	
40	097	BYP Over Temperature	Beep continuously	Light	
41	09A	Output CT Reversed	Beep continuously	Light	
42	09B	Dry-Contact Power Fault	Beep continuously	Light	
43	09C	Dry-Contact Comm. Fault	Beep continuously	Light	
44	09D	BYP Backfeed Fault	Beep continuously	Light	
45	0C1	BYP Par. Cable Fault	Beep continuously	Light	
46	0C2	BYP SCR Broken	Beep continuously	Light	
47	0C5	BYP SCR Short	Beep continuously	Light	
48	0C8	BYP Comm. Fault	Beep continuously	Light	
49	0CA	BYP Initializes Fault	Beep continuously	Light	

50	0CD	BYP Connected Fault	Beep continuously	Light	
51	0CF	BYP Over Temperature	Beep continuously	Light	
52	0D2	BYP Fan Fault	Beep continuously	Light	
53	0D6	BYP Power Fault	Beep continuously	Light	
54	103	BATT Over Volt	Once per second		Light
55	104	BATT Low Pre-warning	Once per second		Light
56	105	BATT Reversed	Twice per second		Light
57	106	BATT EOD	Once per second		Light
58	107	BATT Low Volt	Once per second		Light
59	108	No BATT	Once per second		Light
60	109	Input Phase Reversed	Once per second		Light
61	10A	Input N-Line Lost	Twice per second		Light
62	10B	Mains Freq. Abnormal	Once per 2 seconds		Light
63	10C	Mains Volt. Abnormal	Once per 2 seconds		Light
64	10D	REC Comm. Error	Once per 2 seconds		Light
65	10E	No Mains	Once per 2 seconds		Light
66	10F	REC Set Data Error	Once per 2 seconds		Light
67	121	INV Par. Cable Abnormal	Once per 2 seconds		Light
68	125	Inverter Overload	Once per second		Light
69	126	INV Not Synchronized	Beep continuously		Light
70	129	INV Comm. Error	Once per 2 seconds		Light
71	12A	INV Set Data Error	Once per 2 seconds		Light
72	141	BYP Change to Num	Once per 2 seconds		Light
73	142	PM Quantity Mismatch	Once per 2 seconds		Light
74	143	Parallel Overload	Once per 2 seconds		Light
75	144	BYP Overload	Once per 2 seconds		Light
76	145	Maint. Switch Misuse	Once per 2 seconds		Light
77	146	ECU Comm. Error	Once per 2 seconds		Light
78	147	Rack Par. Cable Abnormal	Once per 2 seconds		Light
79	14B	ECU Par. Cable Abnormal	Once per 2 seconds		Light
80	14C	ECU Abnormal	Once per 2 seconds		Light
81	14E	BYP Phase Reverse	Once per second		Light
82	14F	BYP Unable To Trace	Once per 2 seconds		Light
83	150	BYP Not Available	Once per 2 seconds		Light
84	151	ECU Set Data Error	Once per 2 seconds		Light
85	152	LBS Signal Error	Once per 2 seconds		Light
86	153	Parallel Link Error	Once per 2 seconds		Light
87	161	BYP Par. Cable Abnormal	Once per 2 seconds		Light
88	162	BYP Phase Reverse	Once per 2 seconds		Light
89	163	BYP Unable To Trace	Once per 2 seconds		Light
90	164	BYP Not Available	Once per 2 seconds		Light
91	165	BYP Comm. Error	Once per 2 seconds		Light
92	166	BYP take over no O/P	Once per 2 seconds		Light

93	167	BYP Setting Data Error	Once per 2 seconds		Light
94	181	BATT Fault	Once per 2 seconds		Light
95	183	BATT Over Volt	Once per 2 seconds		Light
96	185	Fire Alarm	Once per 2 seconds		Light
97	186	Smoke Alarm	Once per 2 seconds		Light
98	187	Machine Type Error	Once per 2 seconds		Light
99	188	System Need maintenance!	Once per 2 seconds		Light
100	189	BATT Switch OFF	Once per 2 seconds		Light
101	18A	Eeprom Error	Once per 2 seconds		Light
102	18B	RS485 Sensor Not Connected	Once per 2 seconds		Light
103	18C	Custom alert 03.	Once per 2 seconds		Light
104	18D	Custom alert 04.	Once per 2 seconds		Light
105	18E	Parallel CAN Communication Failure	Once per 2 seconds		Light
106	18F	BMS Internal Fault	Once per 2 seconds		Light
107	190	BMS communication loss	Once per 2 seconds		Light
108	191	Battery Capacity Low	Once per 2 seconds		Light
109	192	Firefighting Alarm	Once per 2 seconds		Light
110	193	Batt Type Error	Once per 2 seconds		Light

### Event Information

No.	Cord	Event	No.	Cord	Event
1	001	Initializing	40	030	Dry. BYP SW Open
2	002	To Standby	41	031	Dry. Output SW Close
3	003	Non-Output	42	032	Dry. Output SW Open
4	004	On Bypass	43	033	INV.Invalid Due To Overload
5	005	On Line	44	034	ECU Work
6	006	Discharged BATT	45	035	LBS Activated
7	007	ECO Activated	46	036	Transfer Times-out
8	008	Automatic Self-Test	47	037	Generator Access
9	009	Inv In Soft Starting	48	038	Generator Disconnect
10	00A	System Fault Detected	49	039	Batt. Trip Activated
11	00B	Maint. BYP Mode	50	03A	Batt. Trip Stop
12	00C	EPO Activated	51	03B	BYP Takeover Mode
13	00D	Joint Power Supply	52	03C	Unit Online
14	00E	Enter Self-Aging Mode	53	03D	Unit Offline
15	015	REC EPO Mode	54	03E	Dry. BATT SW 2 Close
16	016	REC Curr Limt	55	03F	Dry. BATT SW 2 Open
17	017	REC Activated	56	040	Dry. BATT Trip Activated
18	018	REC Deactivated	57	041	Dry. BYP Feedback
19	019	P-Batt Boost Charging	58	042	REC EPO Clear
20	01A	P-Batt Float Charging	59	043	REC Curr Limt Clear
21	01D	BATT Testing	60	044	REC Mains Input
22	01E	Inverter Work	61	045	REC BATT Input
23	01F	Enter Sleep Mode	62	046	End of BATT Self-Test
24	020	Shutdown Due To Overload	63	047	Inverter Standby
25	021	On Bypass Due To Overload	64	048	Inverter Self-Aging
26	022	INV EPO Mode	65	049	Exit Sleep Mode

27	023	Maint. SW Close	66	04A	Inverter EPO Cancel
28	024	Maint. SW Open	67	04B	Startup capacity is normal
29	025	Input SW Close	68	04C	ECU Off
30	026	Input SW Open	69	04D	ECU Standby
31	027	BYP SW Close	70	04E	Dry. Thunder Protect Normal
32	028	BYP SW Open	71	04F	Dry. Thunder Protect Fault
33	029	Output SW Close	72	050	Dry. BATT Grounded Normal
34	02A	Output SW Open	73	051	Dry. BATT Ground Fault
35	02B	Dry. Maint. SW Close	74	052	ECU Takeover Mode
36	02C	Dry. Maint. SW Open	75	056	Enter cabinet sleep mode
37	02D	Dry. BATT SW Close	76	057	Exit cabinet sleep mode
38	02E	Dry. BATT SW Open	77	058	Dry. BATT SW 3 Close
39	02F	Dry. BYP SW Close	78	059	Dry. BATT SW 3 Open

## 4.5 Options

### SNMP card

- ◆ Loosen the 2 torque screws (on each side of the card).
- ◆ Carefully pull out the card. Reverse the procedure for re-installation



### Functions

- ◆ Support multiple operating systems (Windows、Mac、Linux)
- ◆ UPS can be monitored remotely through the network;
- ◆ Can realize web-based user interface;
- ◆ Support e-mail alarm;
- ◆ Multi-user permission management;
- ◆ Support DHCP;
- ◆ Support remote self-testing, shutdown and restart UPS functions (UPS support required);
- ◆ Support telnet, SSH, Web page configuration;
- ◆ Support scheduled tasks (timed self-test, power on/off);
- ◆ Historical events and historical data storage functions;
- ◆ Remote UPS monitoring and management can be performed through HTTP, SNMP, SSH, Telnet;
- ◆ Complete equipment event handling (including event recording and notification);
- ◆ Can be extended to connect 2 channels of temperature and humidity monitoring modules;

### Features

- ◆ Networking methods: IP-based LAN, WAN, Internet, wireless Ethernet, etc.;
- ◆ User permission management, safe, confidential and reliable;

- ◆ Support multiple configuration management methods such as Telnet, SSH, Web;
- ◆ Support scheduled task function, allow setting scheduled UPS on/off, scheduled battery discharge, etc.
- ◆ Support storage of 50, 000 historical data and 5, 000 historical event records;
- ◆ Built-in ultra-long-life system clock, support automatic timing to achieve time synchronization;
- ◆ Support SNMP V1/V2/V3, HTTP, DHCP, SSH, SSL and other network protocols;
- ◆ Support IPV6;
- ◆ Support the expansion of 2-channel ambient temperature and humidity monitoring modules;
- ◆ Support e-mail alarm function;

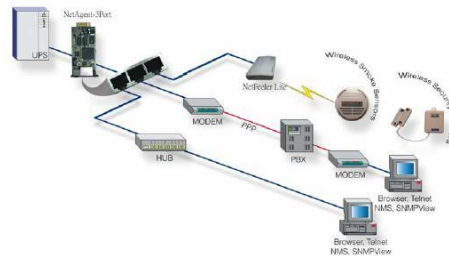

Typical topology of the UPS Network Management

### Relay card

A 10-pin terminal is supported to offer the signals of Bypass, Utility Failure, Inverter On, Battery Low, UPS fault, UPS Alarm, and UPS Shutdown.

The relay communication card contains six dry contact outputs and one dry input. The inputs and outputs are factory programmed according to functions listed in the table

Table: Relay Contacts (communication card)

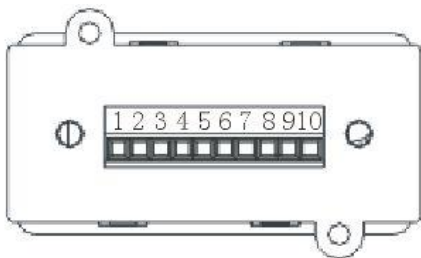

Port		Function
1	Output	Utility Failure
2		/
3		Battery Low
4		On Bypass
5		UPS Fault
6		Inverter On
7		UPS Alarm
8		COM
9	Input	ON
10		OFF



### CAUTION!

The output contacts numbers for a second relay board installed will be 1 to 7. Contacts are NO (normally open) type.



Model		600kVA
Cabinet capacity (VA/W)		600k 600k
Module capacity (VA/W)		50k / 50k
Max. module number		12
Input	Phase	3 Phase 4 Wires and Ground
	Rated Voltage	380/400/415Vac
	Voltage Range	138~485Vac <ul style="list-style-type: none"> <li>◆ At 40°C: The UPS works at full load when the voltage is 323~485Vac and is derated load when the voltage is 323~138Vac</li> <li>◆ At 30°C: The UPS works at full load when the voltage is 305~485Vac and is derated load when the voltage is 305~138Vac</li> </ul>
	Frequency Range	40Hz-70Hz

74

	Power Factor	≥0.99	
	Current THDi	≤3%(100% nonlinear load)	
	Bypass Voltage Range	Max.voltage: 220V:+25 %( optional +10%, +15%, +20%); 230V:+20 %( optional +10%, +15%); 240V:+15 %( optional +10%); Min. voltage:-45 %( optional -10%, -20%,-30%) Frequency protection range: ±10%	
Output	Phase	3 Phase 4 Wires and Ground	
	Rated Voltage	380/400/415Vac	
	Power Factor	1	
	Voltage Regulation	±1%	
	Frequency	Utility Mode	±1%/±2%/±4%/±5%/±10%of the rated frequency(optional)
		Battery Mode	(50/60±0.1)Hz
	Crest Factor	3:1	
THD	≤2% with linear load ≤4% with non linear load		
Overload	Inverter overload capability: <ul style="list-style-type: none"> <li>◆105% &lt; load ≤ 110%: transfer to bypass mode after 60 min</li> <li>◆110% &lt; load ≤ 125%: transfer to bypass mode after 10 min</li> <li>◆125% &lt; load ≤ 150%: transfer to bypass mode after 1 min</li> </ul> Bypass overload capability: <ul style="list-style-type: none"> <li>◆Temperature ≤ 30°C, load ≤ 135%: run for a long time</li> <li>◆Temperature ≤ 40°C, load ≤ 125%: run for a long time</li> <li>◆1000% load: run for 100 ms</li> </ul>		
Battery	VRLA Battery Voltage	Optional Voltage: 360/372/384/396/408/420/432/444/456/468/480/492/504/516/528/540/552/564/576/588/600Vdc(30//31/32/33/34/35/36/37/38/39/40/41/42/43/44/45/46/47/48/49/50pcs optional) 360Vdc~600Vdc (30~50 pcs, 30 pcs define, 36 ~ 50 pcs no power derating; 32~35 pcs output power factor 0.9;30/31 pcs output power factor 0.8;)	
	Li Battery Voltage	512Vdc	
	Module charge current (A) max.	20A	
Transfer Time		Utility to Battery : 0ms; Utility to bypass: 0ms	
Protection	Short Circuit	Hold Whole System	
	Overheat	Line Mode: Switch to Bypass; Backup Mode: Shut down UPS immediately	
	Battery Low	Alarm and Switch off	
	Self-diagnostics	Upon Power On and Software Control	
	EPO	Shut down UPS immediately	
	Battery	Advanced Battery Management	
Noise Suppression		Complies with EN62040-2	
Communication Interface		BMS, RS232, RS485, Dry contact port, LBS, Parallel, Relay card, SNMP card(optional)	
Environment	Operating Temperature	0°C~40°C	
	Storage Temperature	-25°C~55°C	
	Humidity	0~95% non condensing	
	Altitude	< 1500m	

73

<b>Display</b>	Audible & Visual	Line Failure, Battery Low, Overload, System Fault
	Status LED	UPS Fault, Alarm and normal
	Reading On the LCD	Input Voltage, Input Frequency, Output Voltage, Output Frequency, Load Percentage, Battery Voltage, parameter set, history record...
<b>Other</b>	Standard cabinet Dimensions(W*D*H) (mm)	1200*850*2000
	Full cabinet Dimensions(W*D*H) (mm)	
	Module Dimensions(W*D*H) (mm)	440*620*130
	Cabinet Weight (Kg)	530
	Module Weight (Kg)	35
<b>Safety Conformance</b>		CE,EN/IEC 62040-3,EN/IEC 62040-1

## Appendix 2 Problems and Solution

In case the UPS cannot work normally, it might be wrong in installation, wiring or operation. Please check these aspects first. If all these aspects are checked without any problem, please consult with local agent right away and provide below information.

- (1) Product model name and serial number, which can be found on LCD display rear cover and power module side.
- (2) Try to describe the fault with more details, such as LCD display info, LED lights status, etc.

Read the user manual carefully, it can help a lot for using this UPS in the right way. Some FAQ (frequently asked questions) may help you to troubleshoot your problem easily.

No.	Problem	Possible reason	Solution
1	LCD not display	The network cable is not fixed properly or the telephone line of the front door is not fixed properly.	Connect the network cable and telephone cable properly.
2	LCD Blue screen	LCD is Interference	Take out the cable and insert back properly
3	Utility is connected but the UPS cannot be powered ON.	Input power supply is not connected; Input voltage low; The input switch of the module is not switched on.	Measure if the UPS input voltage/frequency is within the window. Check if all modules input are switched on
4	Utility normal but Utility LED does not light on, and the UPS operates at battery mode	The input switch of the Modules are not switched on; input cable is not well connected	Switch on the input switch; Make sure the input cable is well connected.
5	The UPS does not indicate any failure, but output do not have voltage	Output cable does not well connected	Make sure the output cable is well connected.
6	The UPS module cannot transfer to bypass or inverter	Module does not well inserted; The left coronal screw is not tight. Output switch do not switch on	Pull out the module and insert again; Tighten the screw; Switch on the output switch.



7	The UPS module fault LED remains ON	The module is already damaged	Take out this module, replace with a new module.
8	Utility LED is flashing	Utility voltage exceeds UPS input range.	If the UPS operates at battery mode, please pay attention to the remaining backup time needed for your system.
9	Battery LED is flashing but no charge voltage and current	Battery switch does not switch on, or batteries are damaged, or battery is reversely connected. Battery number and capacity are not set correctly.	Switch on the battery switch. If batteries are damaged, need to replace whole group batteries, Connect the battery cables correctly; Go to LCD setting of the battery number and capacity, set the correct data.
10	Buzzer beeps every 0.5 seconds and LCD display "output overload"	Overload	remove some load
11	Buzzer long beeps, LCD display "output short circuit"	The UPS output is in short circuit	Make sure the load is not in short circuit, and then restart the UPS.
12	The LED of the Module with RED light	The module is not inserted properly.	Pull out the module and insert properly.
13	The UPS only works on bypass mode	The UPS is set to ECO mode, or the transfer times to bypass mode are limited.	Set the UPS working mode to Single Module type(non-parallel) or to reset the times of transferring to bypass or re-start the UPS
14	Cannot Black start	Battery switch is not properly closed; Battery fuse is not open; Or Battery low	Close the battery switch; Change the fuse; Recharge the battery
15	Buzzer beeps continuously and LCD indicates Rectifier fault or output fault	UPS is out of order	Consult with your local agent for repair

### Appendix 3 BMS communication port definition

Definition of port:

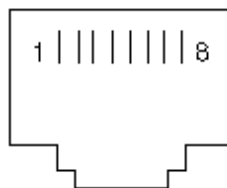

Connection between the BMS's CAN or RS485 port and UPS BMS's CAN or RS485 port.

BMS	UPS (RJ45)	Description
PIN 1	PIN 1	CAN_H
PIN 2	PIN 2	CAN_L
Pin 4	Pin 4	485 - "B"
Pin 5	Pin 5	485+ "A"
PIN 7/8	PIN 7/8	GND

Available function of BMS

- ◆ Communicate to Li battery BMS.

Baud rate ----- 9600bps

Byte length ----- 8bit

End bit ----- 1bit

Parity check -----none

## Appendix 6 LBS port definition

Definition of port:

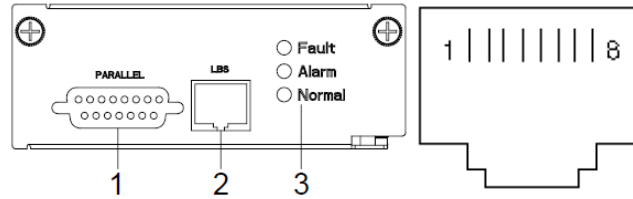

Connection between the UPS LBS port.

UPS(RJ45)	UPS(RJ45)	Description
Pin 1/2/3	Pin 1/2/3	LBS
Pin 5/7/8	Pin 5/7/8	GND

Available function of LBS

- ◆ The output power of two or more UPS in non-parallel system should be synchronized with each other.
- ◆ The output phase of two or more UPS in non-parallel system should be synchronized with each other.



### CAUTION!

Two or more LBS cables must be used to form a ring when two or more LBS in non-parallel system. And the cables must use horizontal line.

## Appendix 7 REPO instruction

Definition of port:

Connection diagram:

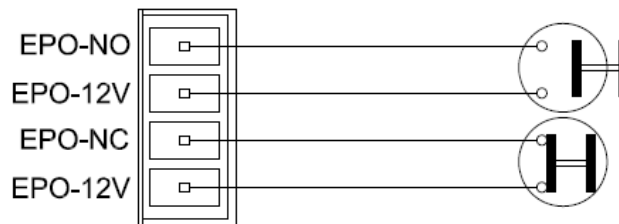

Connection between the button and UPS REPO port.

Button	UPS REPO	Description
Pin 1	Pin 1	EPO-NO
Pin 2	Pin 2	EPO-12V
Pin 1	Pin 3	EPO-NC
Pin 2	Pin 4	EPO-12V

- ◆ A remote emergency stop switch can be installed in a remote location and connection through simple wires to the REPO connector.

## Appendix 8 Dry contact ports

### Definition of input and output ports

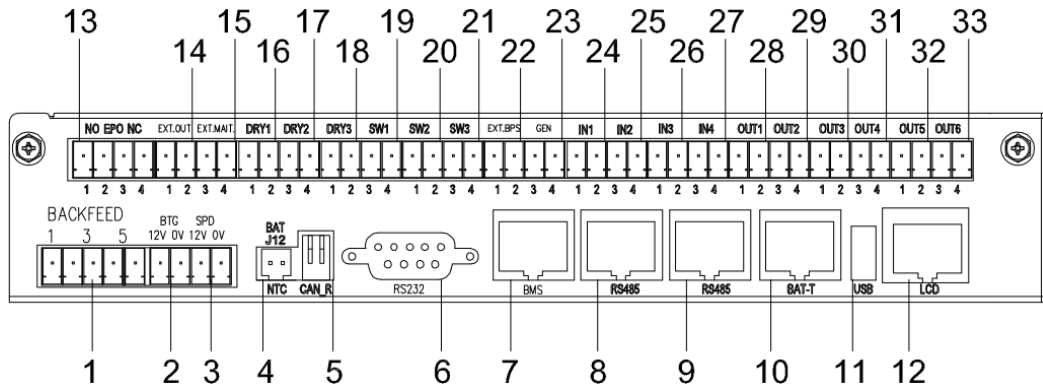

#### 1. Functions of input dry contact ports

No.	Dry contact port	PIN	Function
13	EPO	NO 12V	EPO normally opened port. EPO activation when NO port is shorted to 12V port. When EPO status active the UPS will turn to EPO mode.
		NC 12V	EPO normally closed port. EPO activation when NC port is disconnected from 12V port. When EPO status active the UPS will turn to EPO mode.
14	Switch status	Ext.OUT	External output breaker status dry contact port. Normally opened port. Status activation when Ext. OUT port pin1 is shorted to pin2.
15		Ext.MAIT.	External maintenance breaker status dry contact port. Normally opened port. Status activation when Ext. MAINT port pin3is shorted to pin4. When Ext. MAINT status active the UPS will turn to maintenance bypass if the function is enable.
22		Ext.BPS	External bypass breaker status dry contact port. Normally opened port. Status activation when Ext. BPS port pin1 is shorted to pin2.
19		SW1	External battery breaker status dry contact port. Normally opened port. Status activation when SW1 port pin 3 is shorted to pin4, if the function is enable.
20	Battery grounding tester	SW2	External battery breaker status dry contact port. Normally opened port. Status activation when SW2 port pin 1 is shorted to pin2, if the function is enable.
21		SW3	External battery breaker status dry contact port. Normally opened port. Status activation when SW3 port pin 3 is shorted to pin4, if the function is enable.
2		12V 0V	Battery grounding tester status dry contact port. Normally opened. Status activation when BTG port 12V is shorted to 0V port.
3	Surge protective device	12V 0V	Surge protective device status dry contact port. Normally opened. Status activation when SPD port 12V is shorted to 0V port.
23		12V 0V	Generator Set status dry contact port. Normally opened. Status activation when GEN port 12V is shorted to 0V port. When gen status active the UPS will disable the DC charge if the function is enable.
24-27	IN 1-4	12V-GND	Normally opened. When IN port pin 1(3) is shorted to pin2(4), if the function is enable.

## 2. Functions of output dry contact ports

No.	Dry contact port	PIN	Function
16	Battery breaker driver	DRY1	Battery group 1 breaker driver port. Normally opened port. DRV activation when battery discharge and voltage to EOD. Then DRV port will sent +24V voltage to battery breaker coil to trip the breaker off, if the function is enable.
17		DRY2	Battery group 2 breaker driver port. Normally opened port. DRV activation when battery discharge and voltage to EOD. Then DRV port will sent +24V voltage to battery breaker coil to trip the breaker off, if the function is enable.
18		DRY3	Battery group 3 breaker driver port. Normally opened port. DRV activation when battery discharge and voltage to EOD. Then DRV port will sent +24V voltage to battery breaker coil to trip the breaker off, if the function is enable.
1	BP-BACKFEED	1	1 is connected to relay common pin, 3 is connected to relay NO pin, 5 is connected to relay NC pin. BP- BACKFEED activation when the UPS work on battery mode and then bypass SCR short. It will alarm that bypass input is high voltage. Relay: 270Vac/5A, 125Vac/10A, 30Vdc/3A
		3	
		4	
28-33	Out1-6	OUT-Common	It can chose normally opened or normally closed on the LCD. NO will short to com or disconnect from com when the port is enable. The function of the port as per the table in LCD description section. Relays: 125Vac/0.5A, 30Vdc/2A

## 3. Jumpers of dry contact board:

Dry contactor	Jumper ID	Jumper location	Location(Dry contact board)	
OUT_1	J12	PIN2-3(NO)ON		
OUT_2	J13	PIN2-3(NO)ON		
OUT_3	J8	PIN2-3(NO)ON		
OUT_4	J22	PIN2-3(NO)ON		
OUT_5	J24	PIN2-3(NO)ON		
OUT_6	J25	PIN2-3(NO)ON		
DRV1	UVR trip	J16		PIN1-2(NC)ON
	Shunt trip			PIN2-3(NO)ON
DRV2	UVR trip	J17		PIN1-2(NC)ON
	Shunt trip			PIN2-3(NO)ON
DRV3	UVR trip	J18		PIN1-2(NC)ON
	Shunt trip			PIN2-3(NO)ON

# Appendix 9 Backfeed Protection

## Backfeed Protection

The presence of a backfeed protection is required by IEC 62040-1 UPS standard.

An additional external isolation device must be installed upstream the UPS system. A magnetic contactor or a circuit breaker with UVR (Under Voltage Release) functionality can be used for this purpose.

The isolation device must be able to carry the UPS input current (common input in case of single source, bypass input in case of dual source).

E.g. an isolation device can be a magnetic contactor. The coil of the contactor should be supplied by (eg. fused L1-N voltage) the input source in single mains configurations or by the bypass source in dual mains configurations, via the output port as per Appendix 6.

If the contactor coil exceeds the voltage/current limits of the UPS output port a 24 Vcc source should be generated from the same source the contactor coil is supplied from, in order to supply an additional external auxiliary relay coil. The relay contact, properly rated, should allow to supply the contactor coil.

### Backfeed installation with relay:

1. Connect the UPS backfeed dry contact port to an external +24 VDC supply pole “+”. Route the cable with the other signal cables.
2. Connect the UPS backfeed dry contact to a terminal of the relay R coil. Route the cable with the other signal cables.
3. Connect the terminal of the relay R coil to a +24 VDC supply pole “-” (M).
4. Connect the fuse F, the auxiliary contact of relay R, and the coil of C as shown in the illustration below.
5. Connect C (L1, L2 , L3) with UPS bypass input (L1, L2, L3) as shown in the illustration below.
6. Connect bypass input (N) with mains feeding (N) in the distribution switchgear.

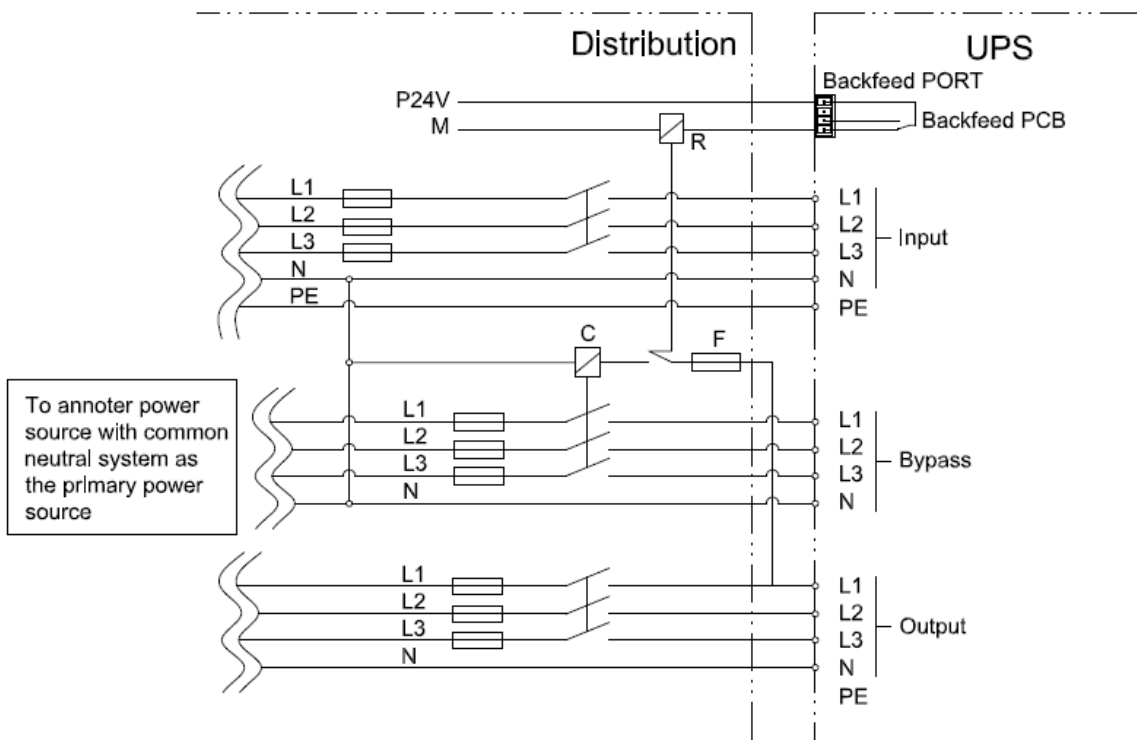

**Backfeed installation without relay:**

1. Connect the UPS backfeed dry contact port 1 to F. Route the cable with the other signal cables.
2. Connect the UPS backfeed dry contact port 4 to the contactor C coil. Route the cable with the other signal cables.
3. Connect the fuse F and the coil of C as shown in the illustration below.
4. Connect C (L1, L2, L3) with with UPS bypass input (L1, L2, L3) as shown in the illustration below.
5. Connect bypass input (N) with mains feeding (N) in the distribution switchgear.

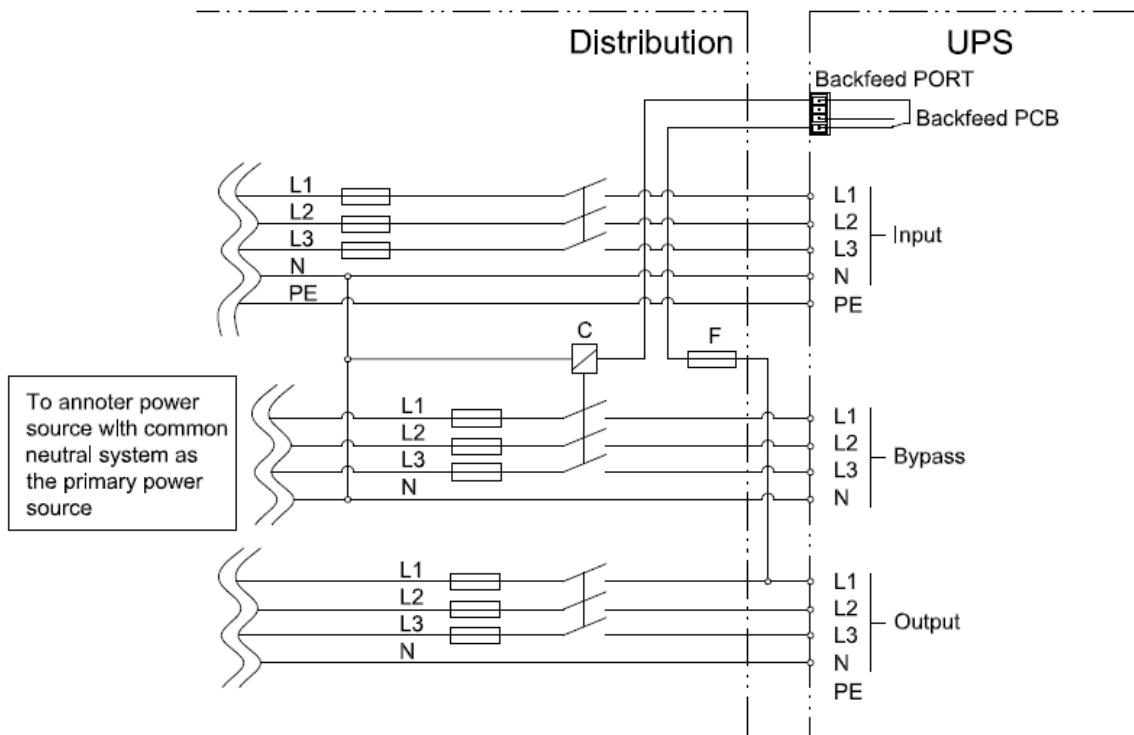



**POWER SOLID**

[WWW.POWERSOLID.VN](http://WWW.POWERSOLID.VN)